

AT MICROFICHE REFERENCE LIBRARY

A project of Volunteers in Asia

A Series of Articles on the Use of Bamboo in
Building Construction

collected by Dr. Jules J.A. Janssen

Published by:

Stichting TOOL
Entrepotdok 68A/69A
1018 AD Amsterdam
THE NETHERLANDS

Available from:

same as above or
Intermediate Technology Publications
9 King Street
London WC2E 8HN
ENGLAND

Reproduced by permission.

Reproduction of this microfiche document in any
form is subject to the same restrictions as those
of the original document.



Committee for International Co-operation Activities



a series of articles
on the use of
BAMBOO
in building construction

collected by dr. Jules J.A. Janssen
University of Technology, Eindhoven
The Netherlands

BAMBOO

CICA publication 82.03

collected by

Dr. Jules J.A. Janssen civ. eng.

Committee for International Co-operation
Activities (CICA)

Sub-Committee Microprojects

Eindhoven University of Technology

P.B. 513

5600 MB Eindhoven

the Netherlands

This publication can be obtained through:

Foundation TOOL

61A Mauritskade

1092 AD Amsterdam

the Netherlands

ITDG bookshop

9 King Street

London WC1E 8HN

England

Second edition, 1982, 400 x.

Free use can be made of the information in
this publication provided the source is
properly indicated.

The Eindhoven University of Technology
cannot be held responsible for the possible
damages resulting from the use of the
information contained in this publication.

INTRODUCTION

In may 1974 a manual on bamboo was published, in Dutch. This manual contained selected articles on the experiences of the Dutch engineers in Indonesia during the colonial period, with the building of houses, roads and bridges. Since these articles have a wealth of practical information, they were considered to be still useful for fieldworkers.

After publication, several requests for an English translation were received and, instead of translating the Dutch text, similar original English material was brought together, resulting in a manual for use by field engineers and community development workers in tropical countries.

In 1982 this English manual has been enlarged with the results of modern research programs.

Jules J.A. Janssen

CONTENT

Chapter 1:	Introduction; advantages and defects of bamboo; preservation	page 5
2:	Housing	21
3:	Bridges	77
4:	Roads	101
5:	Boats and Rafts	109
6:	Water supply	117
7:	Bamboo constructions	131
8:	Bamboo reinforced concrete	163
9:	References and index	171

Chapter 1. : Introduction

- 1.1. - Advantages and defects of bamboo, based on
the publications by MATHUR and McCLURE p. 5
- Preservation of bamboo.
- 1.2. - First, a more fundamental article by
Prof.dr. W. Liese in Gate (1981) no. 1 p. 9
- 1.3. - Next, a practical manual, pages 20...24
and 26 from "Manual of rural wood
preservation" p. 12
(Anybody who is interested in preservation,
is advised to order his copy of this manual
at the address:
Forest Products Research Centre
P.O. Box 1358
BOROKO
Papua New Guinea) . .
- 1.4. - At last, pages 92 + 93 from the U.N.
manual p. 18

Note: this book refers to bamboo in building structures.
However, any reader who is interested in the cultivation
of bamboo, is asked to look into the index and the
references in this book, chapter 9, page 177.

In 1953 Mr. F.A. McClure published his book "Bamboo as a building material". (ref. 10) From this book follow the "Introduction" and a description how different bamboo species might be.

Introduction

Bamboo is one of the oldest materials used by mankind to increase comfort and well-being. In today's world of plastics and steel, bamboo continues to make its age-old contributions and is even growing in importance. Programs of technical cooperation among nations are giving recognition to the unique qualities of bamboo and are bringing about a broad sharing of the varieties of bamboo and the knowledge pertaining to their use. In six Latin American countries, projects are going forward today to test and select outstanding varieties of bamboo gathered from over the world and to determine their potential place in local economies. These projects, now a part of the Point Four program of technical cooperation, have been under way for a number of years and some of them have developed to a point where bamboo's multiform usefulness has become obvious and challenging.

Bamboo is a versatile plant material, whose potential can be harnessed in the service of the humble as well as the great. In its adaptability to human needs, it has few peers in the plant kingdom. In the Occident as well as the Orient, the peoples in whose

environment bamboo is a natural feature have amply demonstrated its claim to a special place in their everyday life.

As technical cooperation continues to single out species with outstanding utility, and to disseminate them more widely, along with the old skills and the new techniques essential to their practical use, the lot of many now underprivileged people will definitely be improved. With a few plants of superior bamboos in the backyard, a family will have at hand the wherewithal to fence the garden, build a pigpen or chicken coop, or add a room to the house. They will also have the means of augmenting their daily income by making baskets or other specialties in spare time for sale or exchange at the market.

If techniques of large-scale, mechanized utilization can be developed—as, for example, in the manufacture of high-quality papers and rayon—new industries and increased national income may be brought to underdeveloped areas. It is with these prospects in view that bamboo is being used as one of the vehicles for implementing the Point Four program.

Differences Among Species

As with steel, bricks, cement, stone, clay, timberwoods, or any other building material, it is necessary to think of the bamboos in terms of individual and distinct kinds, each characterized by a combination of properties peculiar to itself (fig. 23). Certain combinations of these properties are useful for identification; certain ones must be taken into account in evaluating the suitability of individual kinds for one purpose or another. Here are some of the properties that determine the best use of a given bamboo and the relative value of available kinds for a given purpose:

1. Average dimensions of culms
2. Taper of culms
3. Straightness of culms
4. Size and distribution of branches
5. Length of culm internodes
6. Shape and proportions of internodes
7. Thickness of the wood (culm wall)

8. Relative proportions and distribution of different tissues (bundles and parenchyma) in the wood (which affect the properties listed under 9 and 10)

9. Density and strength of the wood

10. Splitting qualities of the wood

11. Susceptibility to fungi and wood-eating insects.

Specifications for bamboos are not yet standardized on a wide geographical scale. Within any bamboo-using community, however, the close observer will find that where there is a choice of several species, certain ones will be used for certain purposes with great regularity. And where there are established bamboo markets, many of the bamboos offered are found to be classified into more or less well-defined grades with distinctive names. Such markets, and the local artisans who work in bamboo, are sources of much useful information not to be found anywhere in print.

Bamboo has advantages, and disadvantages as well. Mathur (ref. 8) gives a summary; we start with:

SOME ADVANTAGES OF BAMBOO HOUSES

1. Bamboos are circular in shape and solid or hollow. As such bamboos can be easily cut into required size or split up with the help of simple tools. This helps in quick construction of houses.

2. At every joint in the bamboo there is a cross partition wall on account of which bamboos at their joints are very hard and do not bend or break easily. Bamboo houses are, therefore, strong.

3. The texture of bamboos is such that they possess a high tensile strength; they are elastic and as such seldom break.

4. The dimensions of bamboo—its length and thickness—are such that bamboos can be conveniently stored and easily used in construction. On account of this, construction of bamboo houses needs less skilled labour.

5. The surface of bamboos is hard and clean. The colour of bamboos is also pleasant. This gives a good appearance to bamboo houses.

6. Bamboos have neither bark nor any material which goes waste. Therefore, bamboo can be used readily as such for house construction. Even though treatment of bamboo is desirable.

7. Bamboos cost very little and in almost every part of our country bamboos of good quality are available at cheap rates. Bamboo houses are, therefore, cheap.

8. When treated bamboos are used for construction of houses and when such houses are maintained properly it is found that bamboo houses have sufficiently good life.

9. Bamboo houses are comfortable to live-in in hot and dry climates as they provide adequate protection from heat.

10. Bamboos are light in weight. As such bamboo houses suffer very little loss due to earthquake. If such houses fall down due to earthquake, these can be reconstructed very quickly and at little cost.

11. Temporary construction with bamboos can be made very quickly at low cost.

12. A variety of useful articles of every day use like tables, chairs, cots, mats, etc. and artistic objects for decoration can be prepared from bamboos. These are very useful for domestic use.

Next, we continue with:

SOME DEFECTS OF BAMBOO HOUSES

The houses constructed with bamboos have some defects which are due to the following:

1. (a) Due to dampness the bamboo starts decaying and rotting very soon.

(b) Termites and borers attack bamboos and by eating it make it hollow. This shortens the life of bamboo structure and renders them dangerous sometimes. As such, houses constructed with untreated bamboos may not be very durable.

2. When bamboo is buried in the ground, it starts decaying very soon and is also eaten away by termites and insects. Therefore, bamboo should not be used in the construction of foundations for houses.

3. Bamboo catches fire very quickly and is burnt to ashes in no time. Bamboo houses, therefore, need fire protection treatment.

4. With the passage of time, the strength of bamboo decreases. This is responsible for short life of bamboo houses.

5. In case of even a small impact force, bamboos are likely to break and split up, and the houses are damaged.

6. Bamboos have joints at different places in its length. Therefore, walls made of bamboo do not have even surface.

7. Bamboos are not of equal length and thickness. This presents some difficulty in construction work.

8. Bamboos on drying shrink and consequently their volume changes. This has an ill-effect on construction done with bamboos.

Some of the defects of bamboos mentioned above can be removed to some extent by proper treatment before their use in construction. The service life of bamboo when treated is increased and the use of treated bamboos in construction results in more durable houses.

Finally, the disadvantages as described by McClure, and how to overcome them.

Shortcomings of Bamboo and How to Overcome Them

The culms of some bamboos have certain characteristics (in combinations, and in degrees, which vary from species to species) that limit or reduce their suitability or versatility as building material. A careful study of these limitations, however, shows that most of them can be overcome, or minimized appreciably.

Variable Dimensions

It is difficult to secure culms very closely standardized to any given set of dimensions. For this reason, the processing or fabrication of bamboo cannot easily be mechanized, and its utilization generally falls within the realm of a handicraft.

With sufficiently large supplies of culms available, the disadvantages of this variability may be overcome to a certain extent by exercising special care in the selection and grading of the material. Further compensation may be achieved by giving special attention to the development of skills in the cutting and matching of pieces.

Uneven Surfaces

The use of certain bamboos is made difficult by the crookedness of the culms, the prominence of the nodes, the unevenness of size and shape of the internodes, and the rate of taper. This unevenness and the taper, which is more marked toward the tip of the culm, may make it difficult to achieve a tight, weatherproof, verminproof construction.

To overcome the effects of unevenness, the builder should select bamboos with use requirements in mind. The different portions of each culm should be classified according to their dominant characteristics, and the culms should be cut up on this basis. The various cuts should be segregated into groups according to the purposes for which they are best suited. Zigzag or curved culms may be used for purposes where shape is unimportant, or where they may give an artistic effect. Special processing, such as

dressing off nodes of whole culms, may permit closer fitting. Culms may be split to make boards or lathlike strips. Finally, the design of the structure and its architectural details may be modified to a certain extent to utilize more effectively the nature and peculiarities of the building material.

Extreme Fissibility

With the exception of thick-walled bamboos such as Bambusa tulda and Dendrocalamus strictus, or those with relatively soft wood, such as certain species of Guadua, bamboos have a tendency to split easily, a tendency that precludes the use of nails. It also limits the range of techniques suitable for the framing or joining of structural units.

Suggested remedies are to use the less easily split culms of thick-walled species for purposes where high fissibility is a disadvantage; to make end cuts just beyond a node where feasible (the nodes have a higher shear coefficient than the internodes and hence show less tendency to split); to fasten joints by means of thongs or other lashing materials; to chisel or bore holes to accommodate nails, screws, or pegs.

Low Durability

Some bamboos are highly susceptible to invasion and partial destruction by wood-eating insects, such as termites and powder post beetles. Species with relatively low susceptibility may be selected; and the culms may be treated to make them less vulnerable. Cut surfaces at the ends of the culms are places where insects usually effect an entrance and should be treated with special care.

Most bamboos also show high susceptibility to rot fungi, especially under damp conditions and in contact with moist soil. Here again, selection of species will help to overcome the weakness, but some form of preservative treatment should be used to prolong the usefulness of bamboos exposed to moist soil.

Bamboo Methods of Treatment and Preservation

In all its many fields of utilization bamboo is exposed to attack by microorganisms and insects. The service life of the structures therefore is mainly determined by the rate of attack.

I. Service life of bamboo

Bamboo is liable to attack by fungi (brown rot, white rot, soft rot) and especially by insects (beetles, termites). Its durability depends mainly on the climatic conditions and the environment. In general it has been found that untreated bamboo has an average life of less than 1—3 years where it is exposed to atmosphere and soil. Under cover, however, 4—7 years or more may be expected depending on the nature of use and the conditions. Under favorable circumstances bamboo has been in service as rafters or frames for more than 10—15 years. In sea water it is destroyed by marine organisms in less than one year.

Generally speaking, bamboo has a low natural resistance compared with wood. Most of the observations on its durability are based on estimations made on full-sized structures. Special service tests have hardly been carried out so far. Results from graveyard tests are still rare.

Split bamboo is more rapidly destroyed than round bamboo. As regards the natural durability in the culm itself, it was observed that the bottom part has, on average, a higher durability than the middle and top portion. The inner part of the culm is faster attacked than the outer one, because of its anatomical structure. Laboratory experiments under controlled conditions have revealed that bamboo deteriorates more rapidly when attacked by white rot and soft rot fungi than by brown rotters.

Deterioration of bamboo by powder post beetles starts as soon as the culm is felled. This attack can be attributed to the presence of starch, and for the species *Dinoderus minutus* the deterioration was found to be proportional to the starch content. According to some investigations bamboos harvested during summer are more rapidly destroyed than those felled after the rain period. Flowered bamboo, where starch has been depleted, has a higher resistance to beetles, but it appears to be brittle.

The natural durability of bamboo varies according to species; for example *Dendrocalamus strictus* is less resistant to termites than *Dendrocalamus longispatus*.

Because of its low natural durability a preservative treatment is generally regarded necessary. However, such bamboo treatment has seldom been carried out.

The lack of a preservative treatment for bamboo in spite of its widespread utilisation can be related to the following factors:

1. Lack of knowledge about possibilities of bamboo protection.
2. Lack of facilities, both regarding treatment facilities and preservative chemicals.
3. Uncertainty about the advantages of bamboo preservation.
4. No marketing of treated bamboo.

For any consideration of bamboo preservation a knowledge of the available methods, their advantages and disadvantages is necessary. The methods applied in the Asian countries with bamboo resources have therefore been compiled, and a survey is given in the following. Since any efficient treatment depends on the penetrability of the material, the treatability of bamboo has to be discussed first.

II. Treatability of bamboo

The treatability of bamboo is in general rather low. It differs according to species, age and moisture content of the culm, treatment method and type of preservative. Most of these factors are influenced by the anatomical structure. A bamboo culm can be differentiated anatomically from wood by the following characteristics, which are important for the penetration of preservatives:

1. The vessels run strongly axial. They are isolated from each other by the parenchyma in the internodes and connected only in the nodes; they are very small at the periphery of the wall and become larger near the centre.
2. A special layer of cells covers the wall outside and inside and retards penetration from both sides.
3. There are no ray cells in the bamboo tissue — these are essential for an easy movement of liquids in a radial direction.

The penetration of liquid into a culm takes place preferentially in the axial direction from both ends through the vessels. To a small extent movement is also possible through the intercellular cavity and the sieve tubes of the vascular bundles. Some penetration occurs at the nodes where the branches are cut off. The penetration through the cuticula is slow and needs a rather long time. However, from the inner side diffusion is better than from the outer side. In the living culm the cuticula provides protection against water loss in the culm and it is obvious that there also be a low rate of diffusion in dead tissue. Even

under pressure the lateral penetration is very small.

It has been recommended that by incising the inner part of the wall additional openings for penetration may be obtained. But the structure of bamboo is such that a better treatability by this method could only be obtained for short lengths. In another trial, attempts are made to bore axially through the normally impermeable diaphragm of the nodes, so that the culm acts like a vessel for the preservative and the liquid can penetrate easier from the inside wall. In this case it must be ensured that the preservative is removed from the inside of the culm after treatment, otherwise it will be lost, and furthermore wrong absorption values will be obtained.

For a satisfactory treatment of the tissue it is necessary that the preservative diffuses from the vessels into the surrounding fibres and parenchyma cells. The vessels occupy only a small portion — about 5—10% — of the cross-section. Even when the vessels are completely filled the bamboo culm can be destroyed by fungi or insects if the preservative does not diffuse into the tissue enough and the main portion of the culm is thus left untreated. Consequently for the treatment of bamboo, only preservatives which have good diffusion properties should be used.

III. Methods for the protection of bamboo

There are two kinds of methods which may be used to increase the durability of bamboo: non-chemical methods, in which preservatives are not involved, and chemical methods. Whereas non-chemical methods have been used for a long time in the villages of many countries, chemical treatment on a larger scale is applied mainly in India and Taiwan. In Japan, prophylactic treatment and surface protection during processing is common.

1. Non-chemical methods

These are generally the so-called "traditional methods", which are used quite often, though not much is known about their real effectiveness. However, they cost almost nothing and can be carried out by the villagers themselves without special equipment.

Curing: Culms are cut at the bottom, but left for some time with branches and leaves on the clump (clump-curing). Transpiration of the leaves still continues, and so the starch content in the culm is reduced. As a result, the resistance to infestation by borers is said to be increased, but there is

no influence on the resistance to attack by termites or fungi.

Smoking: The culms are stored above fire-places inside houses for some time, so that the ascending smoke causes a blackening of the culm. It is possible that toxic agents are produced which lead to some resistance. Due to the heating, the starch within the parenchyma cells may be destroyed too. In Japan, bamboo material is kept in heating chambers at 120—150 °C for 20 min., which is considered to be in some way effective against insect attack. Cracks can occur, however, which lead to easier attack later.

Whitewashing: Bamboo culms and bamboo mats for housing construction are often painted with slaked lime (Ca(OH)₂). This is done largely because of the ornamental effect of the white colour, although as a side effect a prolongation of service life is expected. It seems possible that the water absorption is delayed by this treatment, leading to a higher resistance to fungi, but special investigations have still to be carried out. The strength of bamboo may be affected by such an alkaline treatment.

In Indonesia, bamboo mats are tarred and later sprinkled with fine sand. As soon as the sand clings onto the mat and the tar is dry, up to four coats of whitewash are applied. Plastering, too, is commonly practised by the people, with cow-dung mixed either with lime or with mortar.

Soaking: This method is commonly used in Asian countries. The freshly cut culms are put into stagnant or running water or mud for a period of several weeks. Since the specific gravity of the culms is less than 1, stones have to be put on the bamboos to keep them under water. Subsequently the bamboo is dried for some days in a shady place.

During the soaking period the starch content of the parenchyma cells — important for the attack by borers — is reduced. The method is therefore said to improve the resistance to borers. This assumption, however, has yet to be proved. It must also be emphasized that the method, on the other hand, does not increase the resistance to termites and fungi. Submergence in water may also lead to a staining effect on the bamboo.

Constructional methods: Much damage can be avoided by placing bamboo posts on stones or on cement walls instead of putting them directly into the ground. By means of such constructional methods the bamboo material can be kept dry, so that at least deterioration by fungi may be prevented. It is strongly recommended that in a bamboo house the basement should be made of concrete work or stones. Treatment with water repellent formulae reduces the hygroscopic properties, with the effect that moulds are kept off.

2. Chemical methods

Methods using chemicals for preservation are generally more effective for the protection of bamboo than non-chemical methods, but they are not in every case economical and applicable.

Fumigation: Fumigation is applied in Japan for insect control by using methyl bromide or other chemicals.

Brushing and spraying: Brushing and spraying of bamboo are rarely carried out other than for prophylactic purposes. These methods have only a temporary effect because of the very low penetration of the preservatives. Both can be applied to prevent borer and moulds attacks.

A prophylactic treatment may be advisable in bamboo depots and paper mills. In the fight against the bamboo borer *Dinoderus minutus* a 5% solution of DDT, 0,5% Gamma-BHC or 0,5% Dieldrin proved to be effective, if permissible.

Bamboo piles, which are placed in the ground, are sometimes tarred and afterwards wrapped in palm fibre ropes.

Butt treatment: The bottom sections of freshly cut bamboo culms, with branches and leaves are placed in a barrel containing the preservative. The transpiration of the leaves, which is still in progress, draws with it the solution into the vessels of the culm. After cutting and subsequent handling, however, air often gets into the vessels at the bottom, thus neutralizing the suction effect of transpiration. Moreover, this method is possible only with rather short culms with high moisture content. It takes a long time, and in most cases the vessels do not take up enough liquid to preserve the surrounding fibres and parenchyma cells sufficiently by later diffusion.

Open-tank method: The open-tank treatment is an economical and simple method with a good protective effect. Culms cut to size are soaked in a solution of a water-soluble preservative for several days. The solution gets into the culm by diffusion through the ends and partly through the sides. Practical investigations carried out on the conditions for open-tank treatment lead to the following results: Immature bamboo shows evidence of much better penetration both through the outer and the inner skin than mature bamboo. This effect may be correlated with the amount of lignification. Both the outer and the inner skins are permeable to some extent to preservatives during longer soaking; the inner skin, however, is a little more permeable than the outer one. Consequently, split culms can be treated more easily than round ones. By using split bamboo, the soaking period would be reduced by 1/3—1/2. Penetration and absorption of water-soluble preservatives are lower in freshly felled culms than in air-dry material.

In air-dry culms diffusion in the axial direction was found to be about 20 times greater than in the transverse direction; radial diffusion is slightly more than the tangential. In the inner part of the wall it is faster than in the outer part. The treating solution should be of a higher concentration when green bamboos are used. Since water absorption in bamboo is generally slower than in treatable wood species, the soaking period has to be considerably longer than that for wood of the same dimensions.

Summarizing it can be stated that bamboo in round and split condition can be satisfactorily preserved by soaking. The duration of treatment depends mainly on the kind of preservative chosen, on the bamboo species and the condition of the culm (Liese 1959, Singh et al. 1965).

By using hot dipping or the hot and cold method the time of treatment can be considerably reduced. Mechanical scratching of the outer skin could speed up the penetration, especially for slow diffusing preservatives.

Boucherie-method: The boucherie method is an effective method if the material to be preserved is available in the green condition. The water-transporting part of the culm can be penetrated completely and the treatment itself involves little — and inexpensive — equipment. In its classical form the preservative is forced by gravity from a container placed higher than the stem through pipes into its base end. The higher the vessel is fixed, the faster the penetration. It is also possible to hang the culm vertically, and to scratch the inner wall of the top internode in order to use it as reservoir for treatment. The internode has to be filled up several times.

At the beginning of the boucherie treatment the solution, dripping from the top end, consists mainly of sap and has to be removed. Later on the solution can be collected and, after the addition of new salts, it may be used again. The treatment is finished when the solution at the dripping end shows a sufficiently high concentration of chemicals.

This method has been improved by application of pneumatic pressure (air pump) over the preservative fluid in a reservoir (A. Purushotham et al. 1953). At the bottom of a container a small metal tube is fixed from which several other tubes leading to the ends of bamboo culms are led off. The culms are fastened to the tubes by rubber sheaths. The preservative is forced axially through the culm by the air pressure in the container. Compared with the classical boucherie method, the time of treatment can be reduced from several days to 3—8 hours. Such boucherie installations are easy to transport and could be used directly in the forest.

The duration of treatment and the effectiveness of this method depend mainly on the bamboo species, the moisture content of the culm and the preservative used. A low initial moisture content results in a higher osmotic pressure of the parenchyma cells surrounding the vessels. Thus the water is withdrawn from the preservative solution inside the vessels, so that precipitation occurs, blocking the vessels. The best results of the boucherie method are therefore obtained during the rainy season or after it; failures may occur during the dry season. Young, immature culms with a high water content are more suitable for treatment than mature ones with low moisture content. The kind of preservative, and in particular its precipitation, adhesion and swelling influences on the cell wall, is also of great importance for successful treatment. Preservatives with a high rate of

precipitation and adhesion generally stop flowing through the culm in a relatively short time, so that the vessels and pits become blocked.

Altogether it can be stated that the period of treatment is considerably reduced by this method compared with the classical boucherie method, thus leading to a more economical preservation. Relatively simple handling and reasonable installation costs make this method suitable for many purposes. The cost of treated culms compared with the cheap untreated culms restricts its use for certain fields of utilization. It is also not applicable for all bamboo species, e. g. *Bambusa arundinacea*, which has thin walls, splits easily and is thorny.

Pressure treatment: Pressure treatment of bamboo is carried out in some countries, both with water based preservatives and with creosote. However, it is expensive and in most cases not economical for cheap materials like bamboo. Neither are there enough plants available for the manufacture of preservatives.

For pressure treatment the material should be air dry to ensure sufficient penetration. During treatment of bamboo in round form, cracks and collapse may occur. This reduces not only the strength of the culm but leads also to inaccurate results when measuring the amount of absorbed preservative. Cracks and collapse arise especially in thin-walled bamboos, so that only thick-walled species should be treated in round condition. Generally, in round culms, the preservative solution penetrates mainly from the cut surfaces and nodes into the culm, but less through the cuticula. Split bamboos show a much higher absorption and penetration than round bamboo. Here the preservative can penetrate from the sides too, thus rendering the treatment effective. In both cases, however, it is necessary that the preservative has the potential to diffuse into the tissue later.

III. Economics of bamboo preservation

So far not much is known regarding the service life of treated bamboo; the available results have been obtained from field tests and less from full-sized structures. Reliable data depend on numerous factors like the method of treatment, kind of preservative, absorption and penetration as well as on the specific condition. In order to make a treatment economical the service life of treated bamboo compared with untreated material should be 10—15 years in the open and 15—25 years under cover.

Similarly there is very little information available on the economy of bamboo preservation. Inasmuch as bamboo is a cheap and easily available raw material, its preservation must also be inexpensive. In some cases, therefore, physical methods like soaking in water are in use — methods which can give only temporary protection. The open tank treatment is recommended as the most economical method. In certain special cases one might also practise the more expensive methods like pressure treatment. Due to the small number of

preservation plants the cost of treatment is additionally increased through transport of the bamboo material from the forest to the plant. Instructions to the consumers are regarded as necessary, since they have to be advised that higher initial expenses will pay off by a much longer service life of treated material. One must also take into consideration the replacement costs, which often amount to much more than the cost of the material itself.

Fire-proofing bamboo could reduce the great losses due to fire hazards, which spread fast over large areas. However, the cost for such treatment would be much higher than for protection against insects and fungi. Therefore, at the present, fire protection is not regarded as of immediate importance.

IV. Conclusions and recommendations for research on bamboo treatment

1. Economical points of view

Bamboo is abundantly available in Asia and widely used as constructional material. In spite of its many excellent properties, bamboo is liable to biological deterioration. Although the culms are reasonably cheap, the repair or the need for re-construction of a bamboo house is a big item for the common man. Therefore the prolongation of the service life of bamboo houses and other bamboo-constructions as well as the prevention of decay during storage are of great importance for the people's economy. Any preservation of bamboo must be cheap, easy to perform and readily available.

2. Constructional methods

More attention should be given to improvement of house construction techniques. In several cases constructional methods can reduce the hazard of attack. The fungal deterioration of the bottom sections of bamboo posts in particular can be prevented by placing them on stone or cement basements instead of putting them directly into the ground.

3. Treatment methods

The benefit of protection by non-chemical methods is still doubtful. It is therefore recommended that more information about their effectiveness be collected and special tests be performed. As regards chemical methods, only simple ones are to be considered. Most of the villages are far from industrial centres, where technical installations could be carried out without difficulty. For the treatment of bamboo posts, mats, and tarjas the open tank method is recommended. It does not need complicated technical installations and can be used in all places of demand. For bamboo culms the butt treatment is also advisable. Special research on the duration of treatment for obtaining sufficient retention and penetration with the available preservatives, taking into consideration the

different bamboo species, age classes and moisture content, is also necessary.

4. Preservative

For any chemical protection only a suitable preservative in a sufficient concentration must be applied. The use of a wrong type of preservative or a low concentration will lead to failure and to mistrust of chemical preservation of bamboo or timber. For bamboo, water soluble preservatives are to be recommended. If treated bamboo is to be used in the open, non-leachable preservatives are called for. As far as possible the preservative should not contain components poisonous to human beings and animals, since in tropical countries it is difficult to observe always the necessary hygienic precautions during treatment.

5. Introduction of bamboo preservation

The introduction of bamboo preservation is a rather difficult task. The consumer will hesitate to pay more for a raw material which has been treated, if he does not know its advantages. Since the preservation of bamboo, especially for houses, would strengthen the economy of the common man, the Government authorities must strongly support the initiation of bamboo treatment.

The following steps are recommended:

- a) Placing of treated and untreated bamboo samples in front of every Forest District, Ranger- and Beat-Office. After a short time the villagers will be forced to notice the great advantages of treated material. The samples should be supplied from one institution, where treatment has been properly conducted.
- b) Installation of open tank bassins at the ranger's or beat offices, so that treatment is controlled by the Forest Service.
- c) Supply of the preservative free of charge, either through the Forest Service, the Agriculture Development Corporation or the Forest Industries Development Corporation as a Government contribution to the people's welfare.
- d) The consumer should treat his own material and should be charged only a nominal fee per piece. If real costs were to be charged, no bamboo preservation could ever be started in the villages; this would consequently lead to a vast amount of destruction of bamboo houses year after year. Such losses, taking place here and there, would weaken the nation's economy in the long run.
- e) An action group for the introduction of bamboo preservation should be established with the following programme set-up:
 1. Collection of information of service life of bamboo structures
 2. Installation of untreated and treated samples
 3. Elaboration of the treatment procedure
 4. Installation of open tank bassins
 5. Inspection of the treatment work
 6. Marketing of treated bamboo. ■

1.3.

This method is for preserving woven bamboo that is going to be in Wet Use. That is, it will be on the outside of a building. If you are preserving bamboo for inside a house, you should use the Octabor Diffusion of Bamboo. It is simpler, cheaper method and will do a good job inside a house.

It is important when treating bamboo, to split it before treating it. Bamboo has a waxy coat on the outside and the preservative cannot go through this. When you split the bamboo, the preservative can soak into the wood from the inside. Remember this and do not try to treat the whole piece of bamboo.

Materials: Here is a list of the things you will need to get before you can treat bamboo.

C.C.A. Salts - This comes in 9.1 kg (20 lb) packages. One of these should make enough preservative to treat the bamboo needed to make a wall 15 metres (50ft) long by 3 metres (10ft) wide. You must decide how much to buy.

Soaking Trough - You will need a trough about 4 metres (13ft) long and big enough to hold plenty of bamboo. You can make a good trough by cutting 2, 200 litre (44 gal) drums in half lengthways and welding them together like a canoe as shown in the picture. You can cut the drums with a cold chisel and hammer, or with an axe. After you have cut the drums, you should flatten the edges with a hammer so that they are not so sharp.



Putting Stones on the Bamboo to Hold it Under the Preservative

After you have welded the drums together, it is a good idea to paint the inside with tar or bitumen. If you do not do this, the preservative will make the drum rust very quickly.

A Mixing Drum - You will need a drum that can hold at least 180 litres (40 gal) of water. A 200 litre (44 gal) drum will do quite well. Put a mark on the side 760 mm (31") up from the bottom. When the drum is filled

to there, it will have 180 litres (40 gal) in it. You can also use a 18 litre (4 gal) drum to measure 180 litres (40 gal) into the drum and mark it that way.

Rubber Gloves - The C.C.A. Salts are very poisonous. Whenever you are touching the preservative, or bamboo that is still wet with preservative, you must wear these.

A Plastic Bucket - You will need a bucket to get the preservative from the mixing drum into the trough. One that holds 6 to 9 litres (1½ gal to 2 gal) will do very well.

INSTRUCTIONS:

Now you are ready to start. Please follow our instructions carefully.

Prepare the Chemical Preservative - Put about 140 litres (30 gal) of water in the mixing drum. Mix in one, 9.1 kg (20 lb) bag of C.C.A. preservative and stir until dissolved, add enough water to fill the drum up to 180 litre (40 gal) mark.

This gives you a 5% solution. That is, 10 litres contains ½ kilogram (1 gallon contains ½ lb) of preservative. For treatment of the bamboo, this concentrated preservative will be diluted with water to give a 2½% solution, containing 2½ kilograms of preservative in 100 litres (2½ lb in 10 gallons).

Split the Bamboo - As we said before, the bamboo must be split open before you treat it. You can do this in whatever way you usually do. After it is split, you may find it easier to handle if you tie the split bamboo into bundles before you treat it.

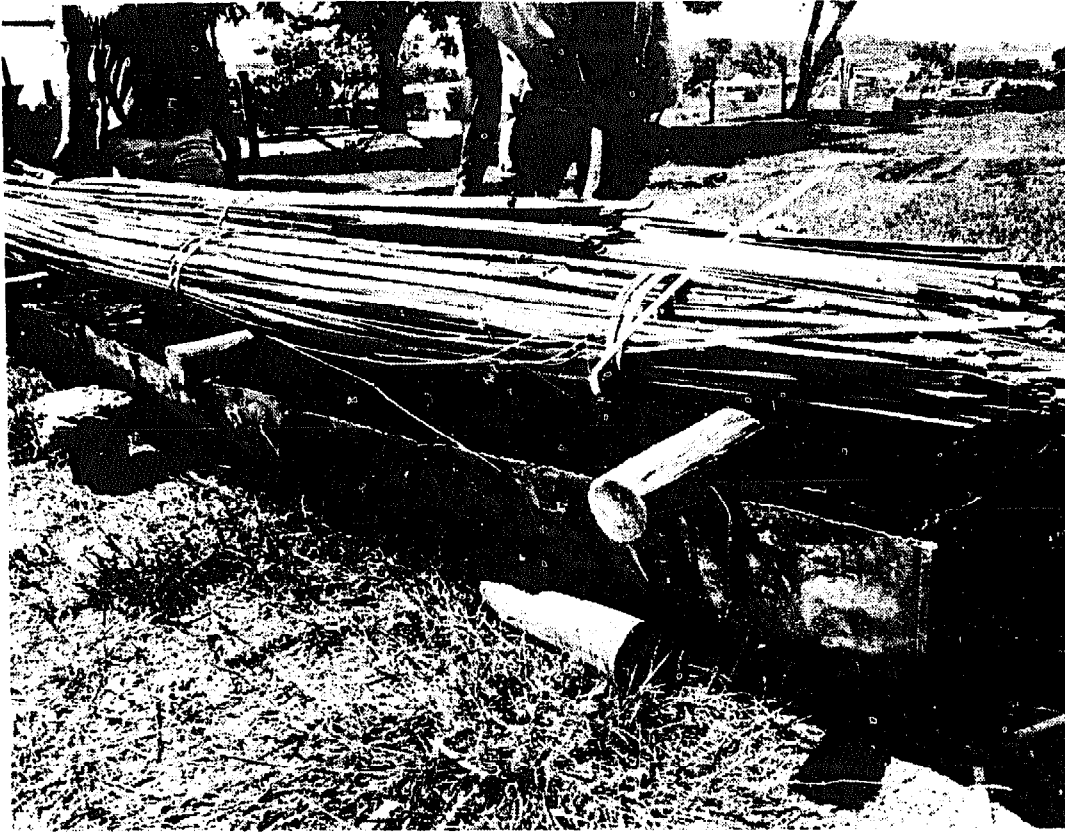
Fill the Trough - Put the bamboo into the trough. Only put enough in so that when you fill the trough up, all the bamboo will be completely covered with preservative. On top of the bamboo, put some big stones so that the bamboo does not float up.

Now you must fill the trough up until the bamboo is all covered. Because the preservative you have mixed is concentrated, you must dilute it. So put one bucket of preservative into the trough and then add one bucket of water. Put another bucket of preservative and another bucket of water. Keep doing this until the bamboo is covered.

Wait 1 Week - The bamboo must soak for at least seven days, so that the preservative can soak in. During this time, you should cover the trough with plastic. This will keep the rain out and stop children or animals from poisoning themselves, with the preservative.

Remove the Bamboo - After 1 week or more, lift the bundles of bamboo up onto sticks laid across the trough and let them drain into the trough. By doing this you do not waste any preservative. After it has drained for a few hours, the bamboo should be set out to dry for a week or more. It is best to do this on a rack set up off the ground.

After the bamboo is dry, you can sue it in your house.



Bamboo Draining Over Trough After Soaking

There will always be bits and pieces of bamboo left over when you have finished weaving it. Do NOT burn these scraps. Bury them in the ground far away from wells and streams. A pit latrine is a good place to bury them.

D. Octabor DIFFUSION OF BAMBOO

This method is for preserving woven bamboo that is going to be in Dry Use, that is, it will not get wet. Bamboo for inside walls or for the inside lining of outside walls, can be treated this way. Bamboo that has been treated by Octabor Diffusion, can also be used on the outside of buildings, IF it is painted. If you want to use bamboo on the outside of buildings and are not going to paint it, the walls should be protected from the rain by wide eaves.

This method is almost the same as the C.C.A. soak. The biggest difference is that we use a different preservative. Octabor is much less expensive and not as poisonous as C.C.A.

You can put Octabor preservative into the bamboo by one or two ways. You can soak the bamboo in a trough of preservative. This is a good method, but you need a trough. The trough is the same as the soaking trough in C.C.A. Soak of Split Bamboo.

The other way is to paint the preservative on and let it soak into the bamboo. This is more work, but you do not need to make a big trough. The end result of both ways is much the same.

If you are only treating a little bit of bamboo, then painting is easier. If you are doing a lot, then it is worthwhile making a trough.

Materials: Here is a list of things that you will need before you can treat the bamboo.

Octabor Preservative - This comes in packages of 3.6 kg (8 lb). Each package is enough to treat about 500 lengths of 4 metre (12ft) long by 50 mm (2") diameter pieces of bamboo. If you are using a trough, you will need some extra, because some will be left in the bottom of the trough. You must decide how many packages you will need to buy.

A Small Drum or Can - You will be mixing up 18 litres (4 gal) of preservative at one time. A drum or a can that will hold this much or a little more is just right. The drum must not leak and should not be rusty.

Soaking Trough - If you are going to use a trough, then you will need to have one made. Read the instructions about this under C.C.A. Soak of Bamboo on Pages 48 and 49.

If you are going to paint the Octabor on, then you will need:-

Plastic Sheet - This will be used to wrap up the pile of bamboo during treatment. Because of this you will need a big piece, big enough to completely cover the bamboo on top, underneath and on all sides. A piece 1.5 x 10 m (8ft x 30ft) should be enough.

Paint Brush - This is for painting the preservative onto the bamboo. You will want a brush about 100 mm (4") wide.

Water - However you put the preservative on, you will need plenty of water, for mixing the preservative and for washing afterwards.

When you have all these things, you will be ready to start. Please follow our instructions carefully.

INSTRUCTIONS:

Prepare the Chemical Preservative - On the side of your mixing drum, put a mark about where you think 14 litres (3 gal) of water comes to and another mark for 18 litres (4 gal). Then fill the drum up to the lower mark with hot water. You can build a fire under the drum if you like. Now put in one package of Octabor, 3.6 kg (8 lb) and stir until it is all dissolved. Finally add enough hot water to fill the drum up to the 18 litres (4 gal) mark. This solution now contains 2 kg per 10 litres (2 lb per gallon). This is a 20% solution.

Prepare the Bamboo - The bamboo should still be green when you treat it. Cut the bamboo, bring it to where you are working, split it and prepare it as quickly as possible. Do not start cutting the bamboo until you have everything else ready.

Using the Soaking Trough - This is exactly the same as the C.C.A. soak, except using Octabor instead of C.C.A. You should read the section on C.C.A. soak of bamboo as well.

Fill the Trough - Put the bundles of bamboo into the trough. Only put enough in so when you fill the trough up, all of the bamboo will be completely covered with preservative. On the top of the bamboo, put some big stones so that the bamboo does not float up.

Now fill the trough up until the bamboo is all covered. Because the preservative you have mixed is concentrated you must dilute it. So put one bucket of preservative into the trough and then add three buckets of water.

Put another bucket of preservative and another three buckets of water. Keep doing this until the bamboo is covered.

Wait 1 Week - The bamboo must soak for at least seven days, so that the preservative can soak in. During this time you should cover the trough with plastic, this will keep the rain out and stop children and animals from poisoning themselves with the preservative.

Remove the Bamboo - After one week, lift the bamboo bundles up onto sticks laid across the trough and let them drain into the trough. See how this is done by looking at the photo in the section on C.C.A. soak of bamboo. By doing this, you do not waste any preservative. After it has drained for a few hours, the bamboo can be used straight away. The Octabor treated bamboo should be kept in a dry place under cover at all times.

It is important not to let this bamboo get wet. If it does, the water will wash out the preservative and your work and money may be wasted.

Painting the Octabor onto the Bamboo - Spread out the plastic on the ground and put a layer of bamboo onto it. The bamboo must be laid with the inside upwards. Paint the bamboo with the 20% solution of Octabor you have made.

Spread another layer of bamboo the same way, inside up. Paint it also with Octabor.

Keep spreading layers of bamboo and painting it with preservative until all the bamboo is on the pile. If this takes more than one day, cover the pile with plastic overnight.

Finally, when you have painted them all, and they are all piled up, cover the pile with sheets of plastic.

Put stones or pieces of wood all around the edge so that no air can get into the pile.

Wait 2 Days - After the two days are over, remove the plastic. The bamboo is now ready to use. It does not have to be dried, but should be kept under cover, out of the rain.

It is important not to get this bamboo wet. If it does, the water will wash out the preservative and all your work and money may be wasted.

Wasted Bamboo - There will always be bits and pieces of bamboo left over when you have finished weaving it. Do NOT burn these scraps. Bury them in the ground far away from wells and streams. A pit latrine is a good place for the scraps.

E. THE USE OF WATER REPELLANT PRESERVATIVE (W.R.P.)

W.R.P.'s are specially prepared mixtures of a fungicide, resin and wax in an organic solvent. When dry timber is dipped in a W.R.P. or the W.R.P. is painted on the cut end of a piece of timber, it is sucked into the timber for a short distance. The solvent evaporates, leaving the fungicide, wax and resin behind. If you can do it, dipping the wood for about three minutes is better than painting the W.R.P. on.

The wax and resin help to seal the pores in the wood and stop water from soaking into the wood. The fungicide will prevent rot starting in the cut end where the W.R.P. was applied.

"Antidotes" for Wood Preservatives

C.C.A.: C.C.A. has a very bad taste and will burn the mouth if someone tries to drink some. It is very poisonous and if someone drinks some C.C.A. preservative, they will die, unless they receive immediate medical attention.

If someone does drink some C.C.A. or Octabor preservative, first make them drink lots of water and then encourage them to throw up (vomit) by placing your fingers down their throat. Then make them drink more water and throw up again. Do this at least three times. If you have milk, use this milk instead of water. (If the person does not vomit easily, then do not waste time, but start moving to the hospital, try to make them vomit some more).

Take some of the preservative and this booklet with you to the hospital so that the doctor will know exactly what has happened.

If someone drinks some preservative and gets immediate attention from a doctor, he will probably be all right.

1.4.

Annex III

RECOMMENDED PRESERVATIVES FOR DIFFERENT END USES OF BAMBOO

End use of bamboo	Recommended preservatives ^{a/}		Concentration of preservative (percentage)	Loading of dry chemical in bamboo (kg/m ³)	Proposed treatment	Expected service life (years)
	Dry bamboo	Green bamboo				
Use in the open and in contact with the ground (e.g., posts, pale-fencing etc.)	a	80 to 128	Open tank or pressure process	15
	b and c	...	6 to 8	8 to 12	Pressure process	
	...	b and c	6 to 8	5 to 8	Modified boucherie (2) for 6 to 8 hours or steeping for 35 to 40 days	
Use in the open but not in contact with the ground (e.g., bridges, scaffoldings, ladders etc.)	a	48 to 80	Hot dipping or open tank or pressure process	15
	b and c	...	5	5 to 8	Pressure process	
		b and c	5 to 6	5 to 8	Modified boucherie for 4 to 6 hours or steeping for 20 to 25 days	
Use under cover:						
(a) House building, walls, trusses, purlins, rafters, tent poles etc.	a (1)	32 to 48	Hot dipping or open tank or pressure process	20 to 30
	b and c	...	4	4	Pressure process	
	d, e and f	...	6	8	"	
		b and c	4	4	Modified boucherie for 4 hours or steeping for 15 to 20 days	20 to 30
		d, e and f	6	8	"	
(b) Screens, ceilings, doors and door panelling, furniture etc.	b and c	...	3	3	Pressure process	10
	d, e, f, g and h	...	5	5	"	10
		b and c	3	3	Modified boucherie for 2 to 3 hours or steeping for 8 to 12 days	10
		d, e, f and g	5	5		
Prophylactic treatment: green bamboos including splints and round bamboos for eventual full-fledged treatment after air-drying	i and j	Dipping for 5 minutes	

a/ The letters in these columns refer to the entries in the following list of preservatives.

(1) Warning: bad smell!

(2) This is Boucherie plus air-pump on the drum.

List of preservatives

- a. Coal tar creosote and fuel oil, 50:50 by weight.
In highly termite-infested areas it is preferable to add 1 per cent dieldrin, and in highly decaying areas 1 per cent pentachlorophenol.
- b. Copper-chrome-arsenic composition (Ascu).
A typical composition of this preservative comprises copper sulphate ($\text{CuSO}_4, 5\text{H}_2\text{O}$), arsenic pentoxide (As_2O_5) and sodium or potassium dichromate ($\text{Na}_2\text{Cr}_2\text{O}_7, 2\text{H}_2\text{O}$ or $\text{K}_2\text{Cr}_2\text{O}_7$) in the proportion of 3:1:4.
- c. Acid-cupric-chromate composition (Celcure).
A typical composition of this preservative comprises 1.68 parts of chromiua sesque oxide (Cr_2O_3) (equivalent to 2.5 parts of sodium dichromate), 50 parts of copper sulphate and 47.5 parts of sodium dichromate.
- d. Copper-chrome-boric composition.
This consists of boric acid (H_3BO_3), copper sulphate and sodium or potassium dichromate in the proportion of 1.5:3:4.
- e. Copper-chrome-zinc-arsenic composition.
A typical composition of this preservative comprises 28 parts of arsenic acid ($\text{H}_2\text{AsO}_4, 1/2 \text{H}_2\text{O}$), 25 parts of sodium arsenate ($\text{Na}_2\text{HASO}_4, 12\text{H}_2\text{O}$), 17 parts of sodium dichromate and 30 parts of zinc sulphate ($\text{ZnSO}_4, 7\text{H}_2\text{O}$).
- f. Chromated zinc chloride.
This consists of zinc chloride (ZnCl_2) and sodium or potassium dichromate in the ratio of 1:1.
- g. Boric acid-borax, 2.5 per cent each.
- h. Copper naphthenate and zinc naphthenate.
These are salts of naphthenic acid and should contain 0.5 per cent of copper and 3 per cent of zinc by weight, respectively.
- i. Dieldrin pentachlorophenol emulsion.
Dieldrin 18 per cent emulsifiable concentrate, 1 part;
PCP 12 per cent emulsifiable concentrate, 4 parts; water, 75 parts by weight. To this may be added copper naphthenate (1 per cent copper) in emulsifiable form, 1 part by weight.
- j. Water solution containing borax 2 per cent, sodium pentachlorophenate 1 per cent, and gammexane (water dispersible), 1 per cent by weight.

Chapter 2.: Housing

- 2.1. - Parts of a House for which Bamboos are
suitable.
McCLURE, pages 2...5 p. 23
- 2.2. - Use of Bamboo for Hutting, Military
Engineer, vol. 7, s. 48, (1950) pp. 45-48 p. 27
- 2.3. - Experience with roofs and trusses in
Tanzania, by the late Frenk A. Failton p. 30
- 2.4. - Hut Construction p. 31
- 2.5. - Technical information on house improvement
for the purpose of controlling the plague 34
- 2.6. - Building with Bamboo, by D. Castro p. 63
- 2.7. - Doors and windows p. 70
- 2.8. - Tools p. 72

Parts of a House for Which Bamboos Are Suitable

Bamboo may be used alone to make all parts of a house except the fireplace and the chimney. Under most conditions, however, bamboo is actually combined with other building materials, such as wood, clay, lime, cement, galvanized iron, and palm leaves, according to their relative suitability, availability, and cost.

The use of bamboo either as a primary, secondary, or occasional source of building material is common only in areas where suitable bamboos grow in sufficient abundance. Importance of bamboo in any given area usually is determined chiefly by the economic level of the common people and by the cost of other, more durable, materials. Structural soundness adequate to the exigencies of local conditions is commonly achieved with bamboo, but a general monotony of design and a mediocre level of execution characterize bamboo houses in many areas. In certain cultural areas, however, and especially at higher economic levels, as among the well-to-do classes of Japan, Java, and Malaysia, bamboo is employed architecturally in ways that are distinctive and basically artistic. Cohen indirectly alludes to this recognition of bamboo's special virtues: "The principal post in a Japanese house characterizes the house with regard to quality and construction. The roof members are trussed to the post, and enable a properly constructed house to stand up to earthquakes and tremors. The writer has seen many houses in which the principal post is of stout bamboo, or in which a stout timber post is given more character by being faced with bamboo."^{1/}

It is my expectation that an architect will presently appear who combines a su-

perior knowledge of, and devotion to, the principles of functional design with an awareness of the possibilities of bamboo as a building material of strength and beauty. Being an artist as well as an architect, he will appreciate the aesthetic qualities of bamboo and its versatility as they have been demonstrated in each area where its use has been lifted to a high plane. Given the right inspiration, the opportunity to travel and to study the best examples of the use of bamboo in building construction, and the cooperation of persons who know the bamboos and the techniques of using them, he will be able to synthesize the best features of bamboo with the technical improvements suggested by his Western background in functional design—and so produce for each cultural area a series of designs and plans that will be a credit to the architecture of our age.

Bamboo has several characteristics that make it a suitable and economical building material for house construction, as well as for the scaffolding (fig. 1) that facilitates such construction:

1. The natural units, or culms, as they are called, are of a size and shape that make handling, storing, and processing both convenient and economical.

2. The culms have a characteristic physical structure that gives them a high strength-weight ratio. They are round or nearly so in cross section, and usually hollow, with rigid cross walls strategically placed to prevent collapse on bending. Within the culm walls the strong, hard tissues of high tensile strength are most highly concentrated near the surface. In this position they can function most efficiently, both in giving mechanical strength and in forming a firm, resistant shell.

3. The substance and grain of bamboo culms make them easy to divide by hand into shorter pieces (by sawing or chopping) or into narrow strips (by split-

^{1/} W. E. Cohen. Utilization of Bamboo in Japan, p. 1. Commonwealth of Australia, Scientific and Industrial Research Organization. South Melbourne, Australia. April 1947.

ting). No costly machines, only simple tools, are required.

4. The natural surface of most bamboos is clean, hard, and smooth, with an attractive color when the culms are properly matured and seasoned.

5. Bamboos have little waste, and no bark to remove.

Foundation

Examples of the use of bamboo posts instead of a conventional foundation for low-cost houses may be seen in both hemispheres. Unless they are treated with some effective fungicidal preservative, however, such posts are not expected to last more than two or three years on the average, or five years at most under unusually favorable conditions. Although no experimental data are available, it seems reasonable to expect that the lasting qualities of bamboo culms set in the ground may ultimately be extended appreciably by applying pentachlorophenol in an appropriate form (see section on preservation). Until reliable and economical treatments have been developed for preserving bamboo that is frequently wetted or is constantly in contact with damp earth, it is considered better to use some material that is more durable than untreated bamboo for foundations—concrete, for example, or stone, brick, or some durable hardwood

When used as supporting posts in low-cost houses, culms should have a fairly large diameter, thick walls, and nodes (points at which transverse diaphragms occur) close together to give maximum resistance to bending. Where large bamboos are not available, smaller bamboos with suitable structural characteristics may be bound together to make composite pillars.

Frame

Next to the foundation and the roof covering, the basic frame is the part of a house most often made partly or wholly of materials other than bamboo. In many regions, those who can afford the difference in cost prefer to use some durable hardwood for frames. They do so partly because hardwoods make stiffer joints and more rigid construction than

bamboo, partly because a greater prestige is generally attached to hardwoods, and partly because certain hardwoods are naturally much more resistant to rot fungi and wood-eating insects than untreated bamboo.

There are certain circumstances, however, under which the superior resiliency of a bamboo frame confers important advantages over a rigid construction. In regions where sharp earth tremors or quakes occur frequently, a bamboo-framed house may survive and remain serviceable longer than any other type.

In the selection of materials for the several types of structural elements, the characteristics of the bamboo should match the function to be performed. Only whole culms are used for the principal parts of a bamboo frame. The dimensions of the various structural elements, and their spacing, are governed by the nature and importance of the function they perform. Stiffness and ultimate strength are important in elements of the frame. To get relatively uniform diameters, and maximum thickness of wood wall (for stiffness and strength), the upper, highly tapered, relatively thin-walled portion of the culms is removed. These tip cuts may be used in wattle-and-daub partitions, or for roof sheathing, where close spacing may make up for the inferior properties of the individual units.

The individual structural elements that compose the frame of a conventional all-bamboo house correspond closely to those found in an all-timber frame: Corner posts, girders or plates, joists, studs, struts or braces, tie beams, king posts, purlins, ridgepoles, rafters, sheathing, and so forth. The use of bamboo imposes certain limitations, however. Mortice and tenon joints cannot be used in framing bamboo: any cut, such as notch or mortice, drastically reduces the ultimate strength of a bamboo culm. The only exception is the notch or saddlelike cut used at the upper end of posts to cradle more securely the horizontal elements that rest upon them (fig. 6, C and D).

With the exception of those of certain species of *Guadua* (notably *G. angustifolia*) and of *Chusquea*, the culms of most bamboos will not take nails without splitting. For this reason, the impinging elements are

generally lashed to each other at their intersections (figs. 6 and 7). In the Far East the withes used for lashings are commonly split from bamboo, more rarely from rattan. Where the available bamboos yield brittle withes, tough vines or the bark of certain trees and shrubs may be used for lashings. In some areas, soft iron wire, most of it galvanized, is used.

Common sense and the empirical knowledge of bamboo craftsmen in various countries constitute the most highly recommended guidance for the selection and use of available material. However, a resourceful person of practical experience in building may often be able to suggest sound and useful modifications of conventional procedures.

Floors

Many bamboo houses have no floor other than the surface of the earth on which they are built. This surface should be, and usually is, raised somewhat by filling with earth, to prevent inundation by drainage water; it may be compacted by pounding. If the fill is made with clay, so much the better, for clay affords a relatively stable surface. The surface of a dirt floor may be made more stable by paving it with bamboo boards. The soil should first be graded to provide natural drainage, but not compacted, before the bamboo boards are laid in place. These may then be pounded with a tamper of suitable design, to drive them into close contact with the surface of the soil, which is compacted by the same operation.

In better houses, the floor is raised above the ground. This arrangement is more hygienic, and provides a sheltered space below the floor, which has many potential uses. In some areas this space is devoted to the rearing of various domestic animals; elsewhere it may be used for the storage of tools and farm equipment, or even farm produce. It may provide a welcome sheltered play space for children in inclement weather.

Serviceable and attractive raised floors may be made entirely of bamboo, given suitable species and a sound structural design. The principal features in conventional design are the supporting beams (part of the basic frame) and the floor covering.

Bamboo culms are more resilient than conventional timbers, and the space between supports should be reduced accordingly.

Spacing specifications must be worked out locally for the individual species of bamboo and the size of culm used.

The floor covering may be made of small whole culms, strips, or bamboo boards made by opening and flattening out whole culms

When the floor consists of bamboo boards, it is generally fastened down by the use of thin strips of bamboo secured to the supporting members by thongs, wire lashings, or small nails, according to local preference and the materials available (fig. 6, B).

Walls, Partitions, Ceilings

The construction of bamboo walls is subject to infinite variation, depending on the strength required (for resistance to natural forces such as hurricanes and earthquakes), the protection desired from rain and ordinary winds, and the need for light and ventilation. Either whole culms or longitudinal halves may be used, and they may be applied in either horizontal or vertical array. They function more effectively, however, when they are vertical, and are more durable; for they dry more quickly after rain.

A form of wall construction widely favored in Latin America is called bajareque—at least in Ecuador. It is made by nailing or lashing bamboo strips or slender culms, horizontally and at close intervals, to both sides of hardwood or, more rarely, bamboo posts. The space between the strips is filled with mud alone or with mud and stones. During this operation, the bamboo strips are more or less completely covered with mud but in time they become exposed by weathering. This form of construction is relatively massive, though less so than walls made of conventional stone, rammed earth, or adobe bricks.

Another form of wall construction, perhaps more widely used, is known in Peru and Chile as quincha. It is a sprung-strip construction, known as lath-and-plaster, wattle-and-daub, or stud-and-mud. In this form, the flexible strips are woven together to provide a base to receive the plaster, which is applied to one side only or to both sides.

A more attractive but less substantial covering may be made of bamboo boards

If these boards are expanded slightly, i.e., stretched laterally, as they

are attached, they provide a suitable base for plaster or stucco. Sometimes barbed wire is nailed to the surface to provide a better bond for the stucco. When whitened with lime or painted with cement, this exterior is very attractive

Partitions are commonly of the lightest construction, such as a thin matting supported by a light framework of bamboo poles. In the Philippine Islands, and generally in the Far East, where suitable bamboos are plentiful, the partitions and even the outer walls of houses are commonly covered with matting woven from thin strips split from the culms. For this purpose, bamboos with thin-walled culms and tough wood, such as many species of the genus *Schizostachyum* afford, are preferred.

The width of the splines, or thin bamboo strips, and the pattern of weave vary locally and according to the desired quality of matting (called *sawale* in the Philippine Islands). Material for matting is sometimes prepared from the culms of thin-walled bamboos by simply cracking the nodes and opening the culms out flat, in much the same way as boards are made

The ceiling may be covered with a closely placed series of small unsplit culms, or by a latticework composed of lathlike strips split from larger culms. Bamboo matting is favored as a ceiling finish in many areas. In some places the ceiling is omitted altogether, permitting the freer circulation of air welcome in hot, humid seasons. This omission has the added advantage of facilitating the dispersal of smoke from the kitchen fire. In the areas where bamboo is used for housing, a chimney would be a curiosity.

Doors and Windows

For practical reasons, window and outside door openings are generally kept to a minimum. They may be framed with wood or bamboo. The doors themselves may be wood, or they may be woven bamboo matting stretched on a bamboo frame, a panel of bamboo boards set in a hardwood frame, or a sturdy gatelike barrier constructed of bamboo bars. Doors are side-hinged, and fastenings vary from the traditional latch-string to lock-and-chain.

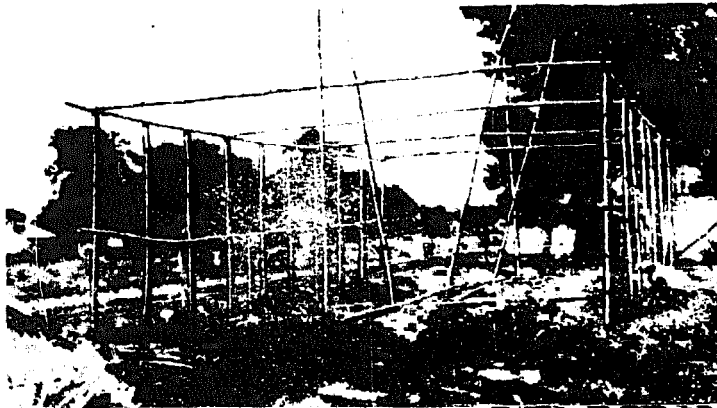
If window openings are provided, they may be framed with bamboo or wood. Most windows are left unglazed and unscreened. Closure may be provided in the form of a bamboo or wooden frame covered with bamboo matting or palm-leaf thatch. Windows are usually hinged at the top; when open—as they are during most of the daylight hours—they serve to exclude the sun's direct rays or light rainfall. At dark the house is closed, to keep out the "night air," generally considered unhealthful. Actually, the closing of houses at night is justifiable on other, more realistic, ground: it prevents the entrance of mosquitoes, rats, bats, and other unwelcome visitors. Permanent window bars of bamboo, many of them painted black to simulate iron bars, are frequently used to frustrate would-be trespassers.

Roof

Because of their high strength-weight ratio, bamboos are used to excellent advantage for structural elements in roof construction (fig. 6, A). In designing the roof, account must be taken of the nature and weight of the roof covering to be used, whether it be grass or palmleaf thatch, halved bamboo culms, bamboo shingles, corrugated sheetmetal, eternite or tile. The dimensions, orientation, and spacing of the individual structural units that support the roof covering are varied to conform to the requirements of the case

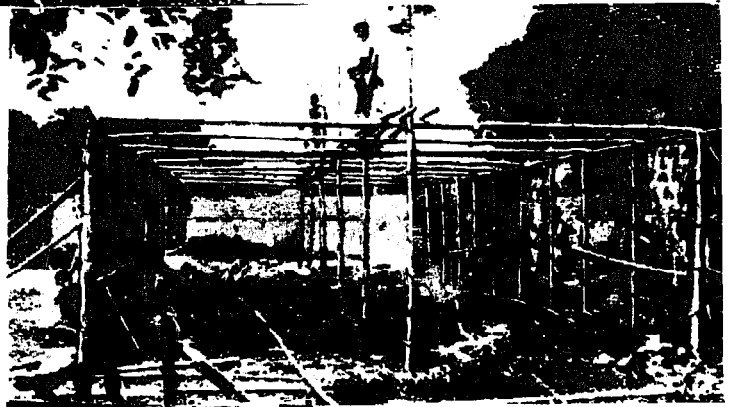
THE ERECTION OF A BAMBOO BUILDING.

A series photographs.



1. Erection of bamboo pole framework. Poles are tied with native vines.

2. Preparation for erecting roof framework.



3. Fabricating walling from split bamboo.

4. Tying walling to bamboo frame.



2.2.

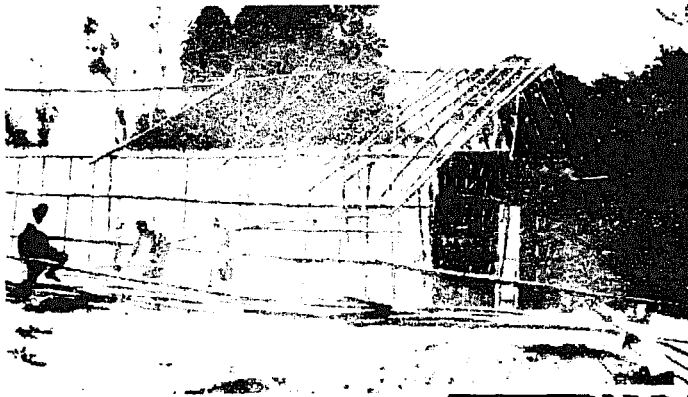
USE OF BAMBOO FOR HUTTING 1)

From: Military Engineer, vol. VII, s. 48,
1950, p. 45-48

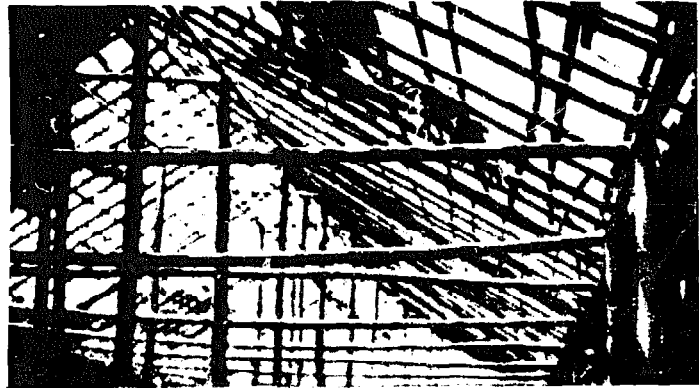
1. Wherever bamboo is plentiful, serviceable hutting can be constructed by using it for the framework and using local thatch or banana leaves for roofing and split bamboo for walling.
2. In Assam and Burma the majority of the native buildings are constructed of bamboo, the local inhabitants being expert in its use. The framework of the walls and roofs of huts can be made of bamboo poles lashed together with local split cane or spun yarn or wire.
For wall covering the bamboos are split and then beaten flat. They are used either in straight lengths or woven into panels.
3. The male bamboo is found up to 3" (7.5 cm.) in dia. and is very strong. The female bamboo, of which there are several kinds, varies in strength. It grows up to 6" (15 cm) in diameter. The stronger types of female bamboo are suitable for the framework of huts, but the weaker types are more suitable for splitting and using for walling.
4. For roofing, bamboo leaves or palm fronds make a good thatch. Banana leaves laid in layers at a good pitch provide a water-proof roofing for temporary work.
5. The photographs on the pages 28 and 29 show the use of bamboo in hut construction.

1)

By courtesy of the Ministry of Defence, London, U.K.



5. Placing bamboo poles to form the roof frame.



6. Framework complete and thatch cover being placed.



7. Placing end gable.



8. View of interior of partially completed building.



9. The roof frame is covered with palm fronds.

2.3.

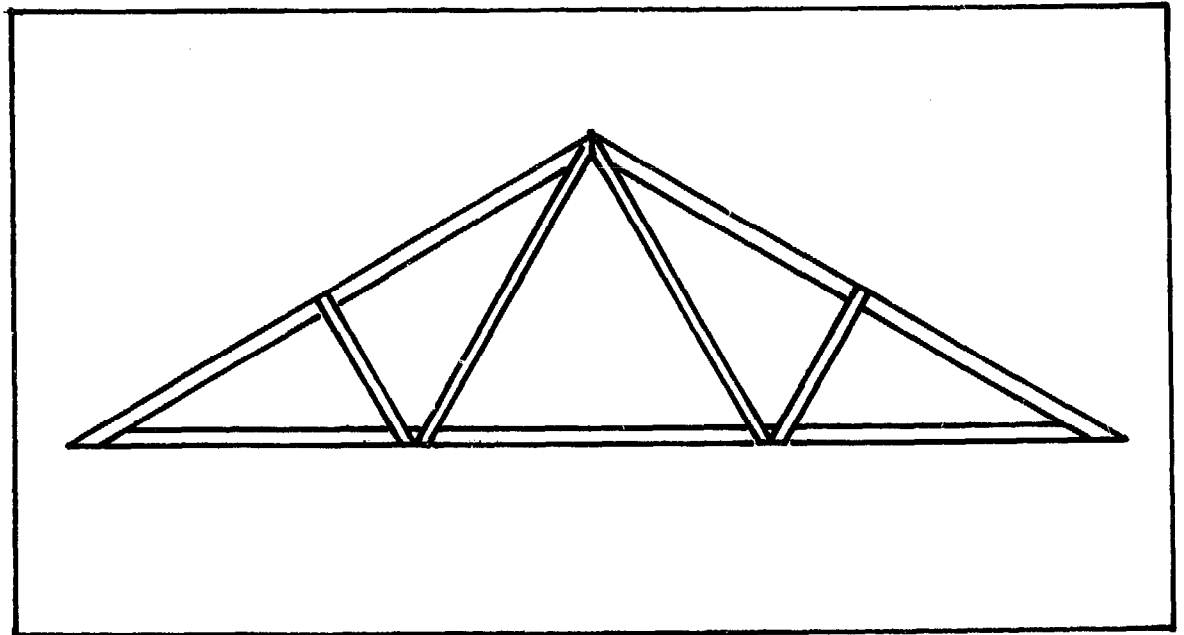
Experience with roofs and trusses in Tanzania.
by the late Frank A. Railton (volunteer)

Faced with the problem of building large quantities of quarters for African labourers, and bedevilled with the usual minimum amount of money available, one had experimented with the use of local materials. One thing which particularly impressed me, was a prefabricated roof, made from the rather small bamboos, which were so prevalent all around.

This roof consisted of a number of roof trusses of about 3.5 to 4 metre span with a 1.7 to 2.0 metre overhang on one side to cover the verandah, constructed entirely of bamboos copying one of the well known triangulated roof trusses, which I cannot remember, but I think it was the one shown herewith.

A number of such trusses were assembled at ground level at 3.5 to 4.0 metre intervals, linked longitudinally by means of bamboo purlins at suitable spacings, and braced longitudinally by further diagonal bamboos to form the wind bracing. The whole formed a very light, but strong, prefabricated roof of any length up to 35 or 40 metres, which 4 to 8 Africans, with the aid of forked poles, could easily lift onto the tops of the mud and wattle or mud-brick walls, which by this time had been built up to wall plate level: it was anchored there by strips of hoop iron, fixed to the walls with long nails, and the roof was then covered with thatch.

Great difficulty was experienced in joining the bamboo components of the trusses. Nailing almost inevitably split all the bamboos, local creepers, and rough cord made from wild *Sansevieria* was then used as bindings, but these rapidly suffered from attack by the almost ubiquitous termite, the so-called White Ant. Eventually the best solution was found to be to wrap the joints in thin hoop iron, which in turn was nailed to the bamboos. The bamboos of course split, but the tight binding of the hoop iron kept the bamboo splinters together. Owing to the dryness of the Ruponda climate, there were no problems from corrosion.



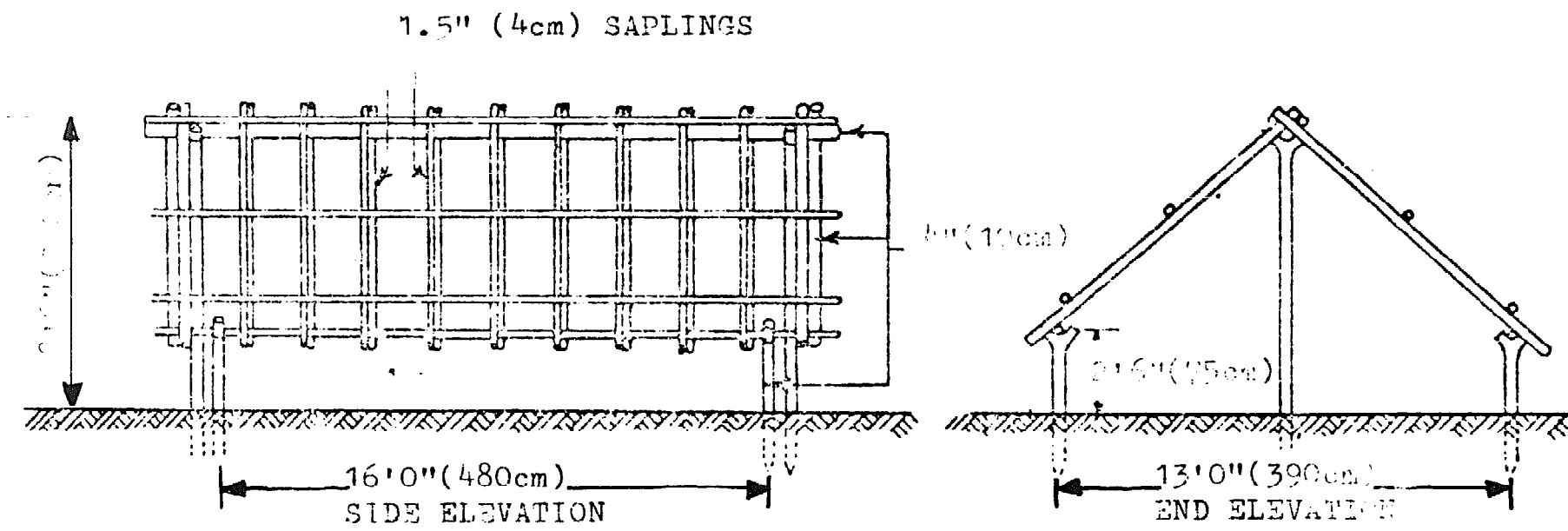
A triangulated roof truss

2.4.

HUT CONSTRUCTION 1)
From: Royal Engineers Training Memorandum (RETM)
no. 17, s. 69, p. 125-127

1. When other accomodation is not available, huts may be rapidly improvised in the Far East using local materials. Page 32 shows a small hut or "basha" capable of being constructed without the use of specialized tools or material. This may be covered with a tent fly, building paper (such as "Sisalcraft", "Malthoid" or "Ormonoid") or by thatching.
2. Standard building materials are frequently in short supply in the Far East. In these circumstances all-purpose hutting can often be improvised from local timber or bamboo. The small hut intended for the temporary accomodation of people may not be suitable for other purposes. Page 33 shows the construction details of a larger hut adaptable to many purposes such as hospital wards, offices, and stores.
3. Although better if available, sawn timber is not a necessity. Satisfactory huts of this design are normally constructed from jungle poles or bamboo, the only stores required being nails and a small amount of wire. It is available to use hoop iron, salvaged from packing cases, for reinforcing points. Thatching if correctly laid makes a good waterproof covering for the roof and is very cool in hot weather.

1) Royal Engineers Training Memorandum.
By courtesy of the Ministry of Defence; London, U.K.



Construction: 4"-2" (10-5cm) saplings lashed with lawyer vine equivalent.

TASK	PERSONS	TOOLS REQUIRED
Frame	5	machettes 1
Thatch	4	2
Total	9	3

Normal output:
One hut per 9 persons in 4-6 hours.

Figure 5. Traditional hut construction.

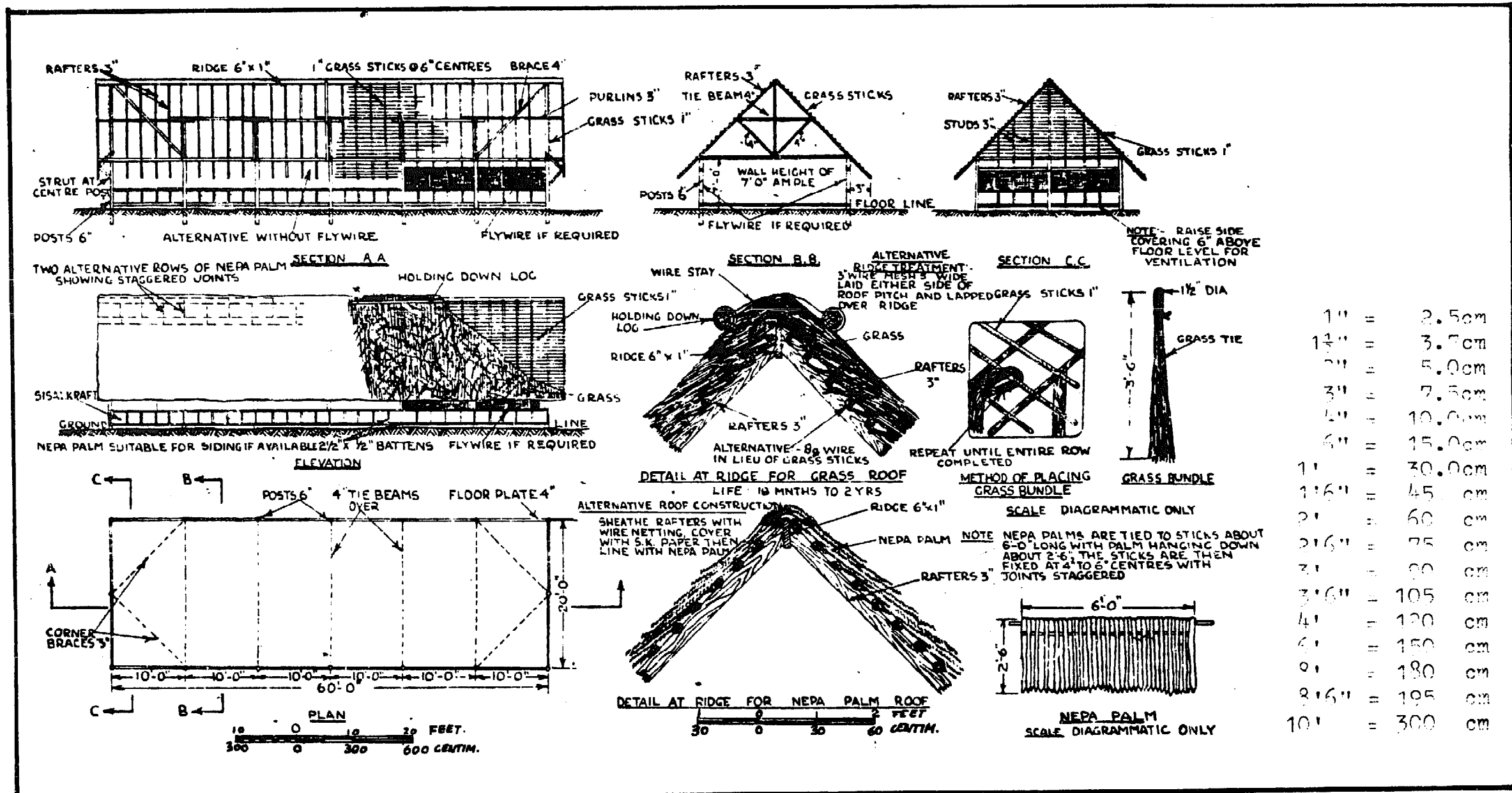
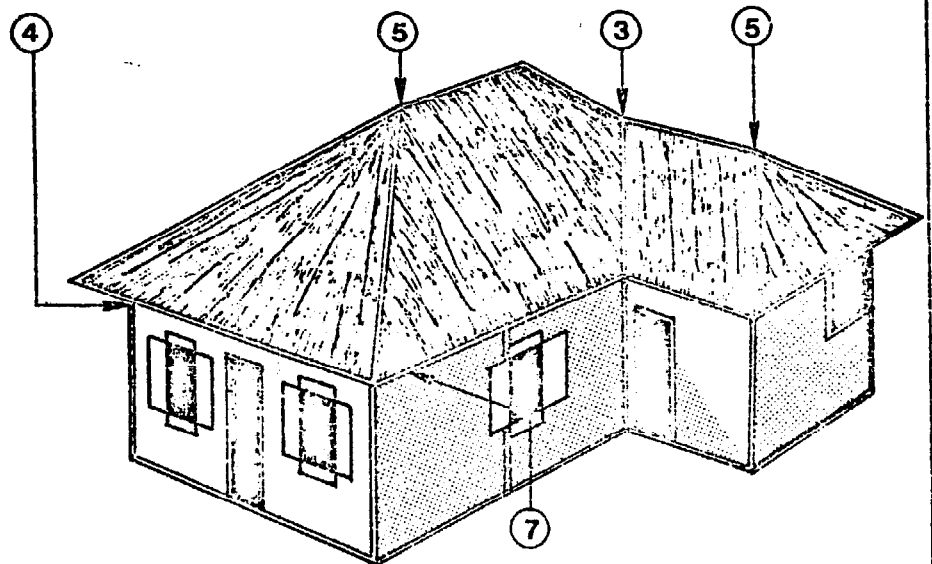
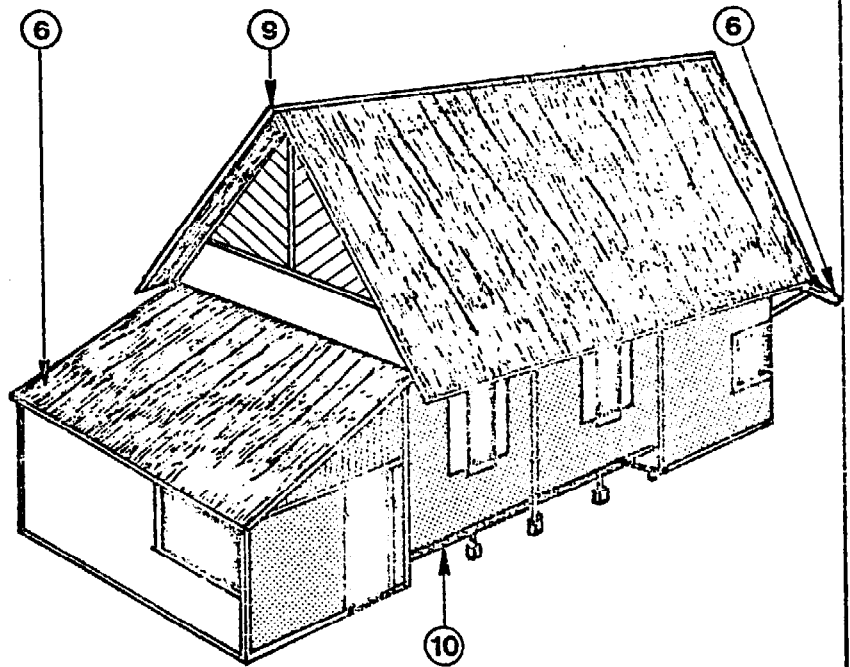
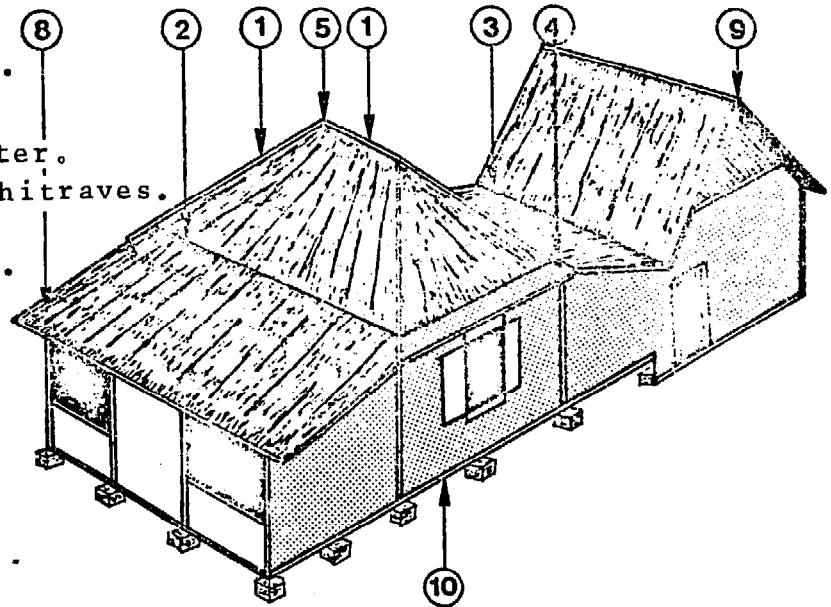


Figure 6. Grass hut construction.

EXPLANATION

1. Ridge purlin and hip.
2. Side purlin
3. Trough or valley gutter.
4. Cornerconnection architraves.
5. Hipconnection.
6. Lean to roof (porch).
7. Eaves.
8. Boarding.
9. Ridge ending.
10. Bamboo floor on top of basement.



2.5.

In the next pages (33....61) an English translation is given of a study by the former Royal Dutch-Indian Medical Services, published in 1935, concerning house improvement for the purpose of controlling the plague.

Technical information on house improvement for the purpose of controlling the plague

When trying to control the plague by improving house construction, the aim should be to avoid contact between rat and man as much as possible. The aim itself already indicates in which way the houses should be improved. Particularly it should be made impossible for the rats to nest without being noticed.

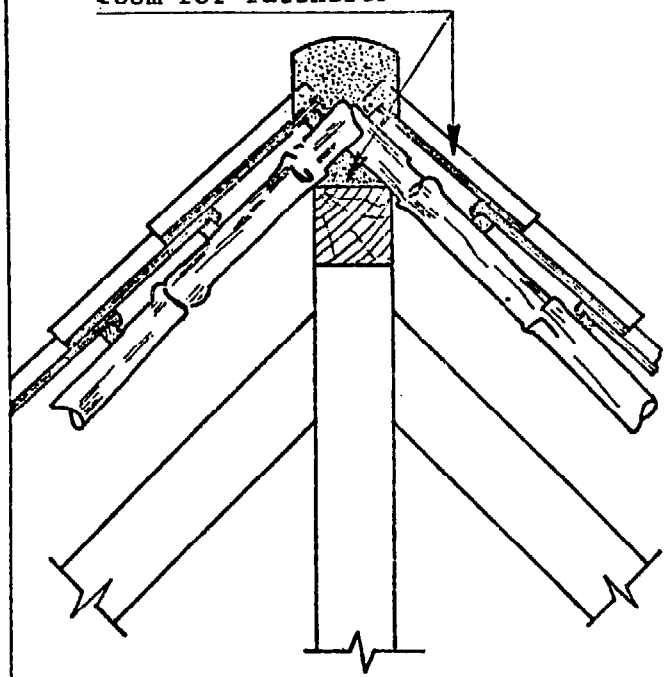
In this text it is emphasized that it is hardly possible to construct all parts of a house in such a way as to give no opportunity for nesting, but if we can make sure that the places where nesting is possible are well visible or can be inspected easily, we have already achieved the goal.

Some constructions dealing with simple dwellings constructed of temporary materials will be described. Furthermore, three constructions, frequently found in stone houses or in shops will also be dealt with. This technical information remains restricted to the improvement of simple contemporary dwellings but the considerations that have lead to the chosen improvements can also give us an idea of how new buildings of both temporary and permanent materials can be kept free of plague-dangerous constructions.

1

RIDGE PURLIN

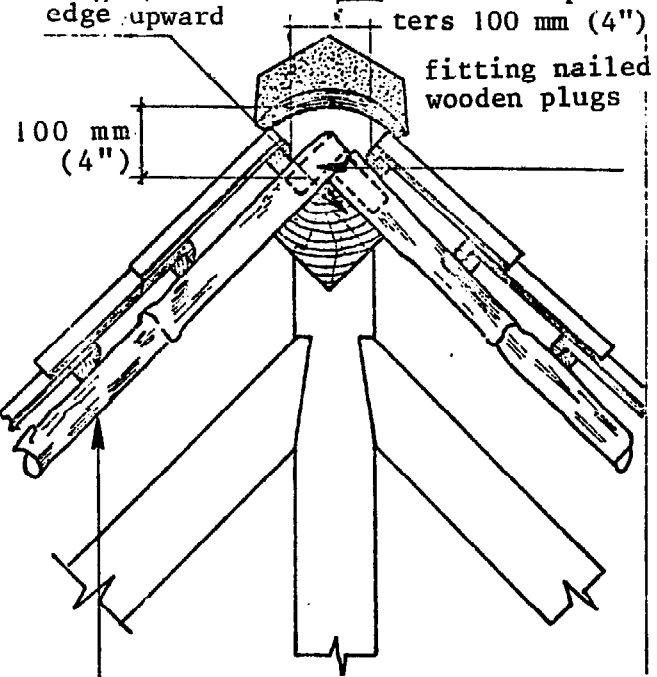
WRONG
room for ratsnests



RIGHT
ridge purlin with
edge upward

distance top bat-
ters 100 mm (4")

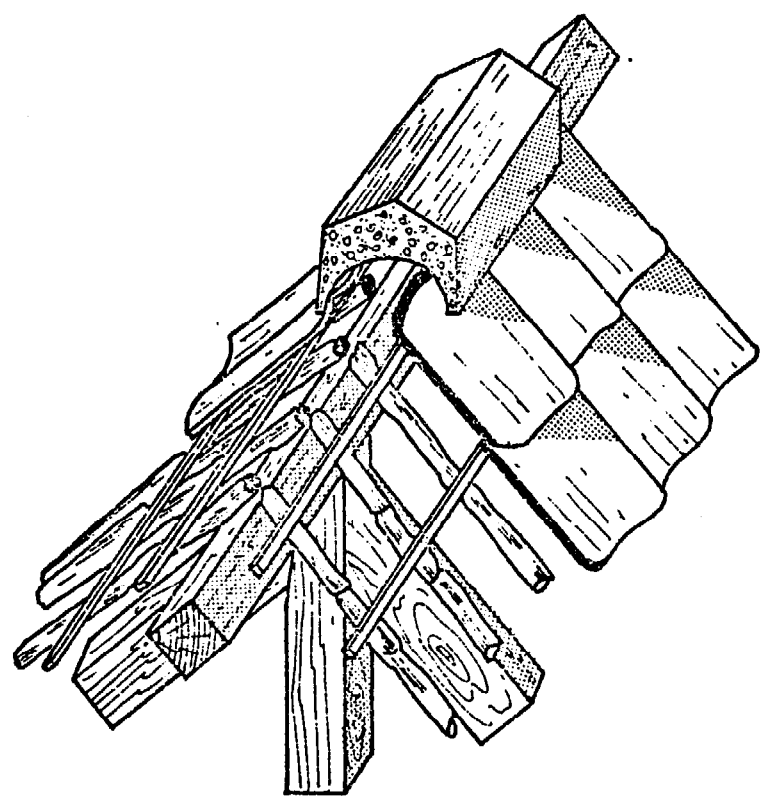
fitting nailed
wooden plugs



100 mm
(4")

rafters at least 50 mm (2") thick
width not more than 50 mm

RIGHT



Ridge purlin

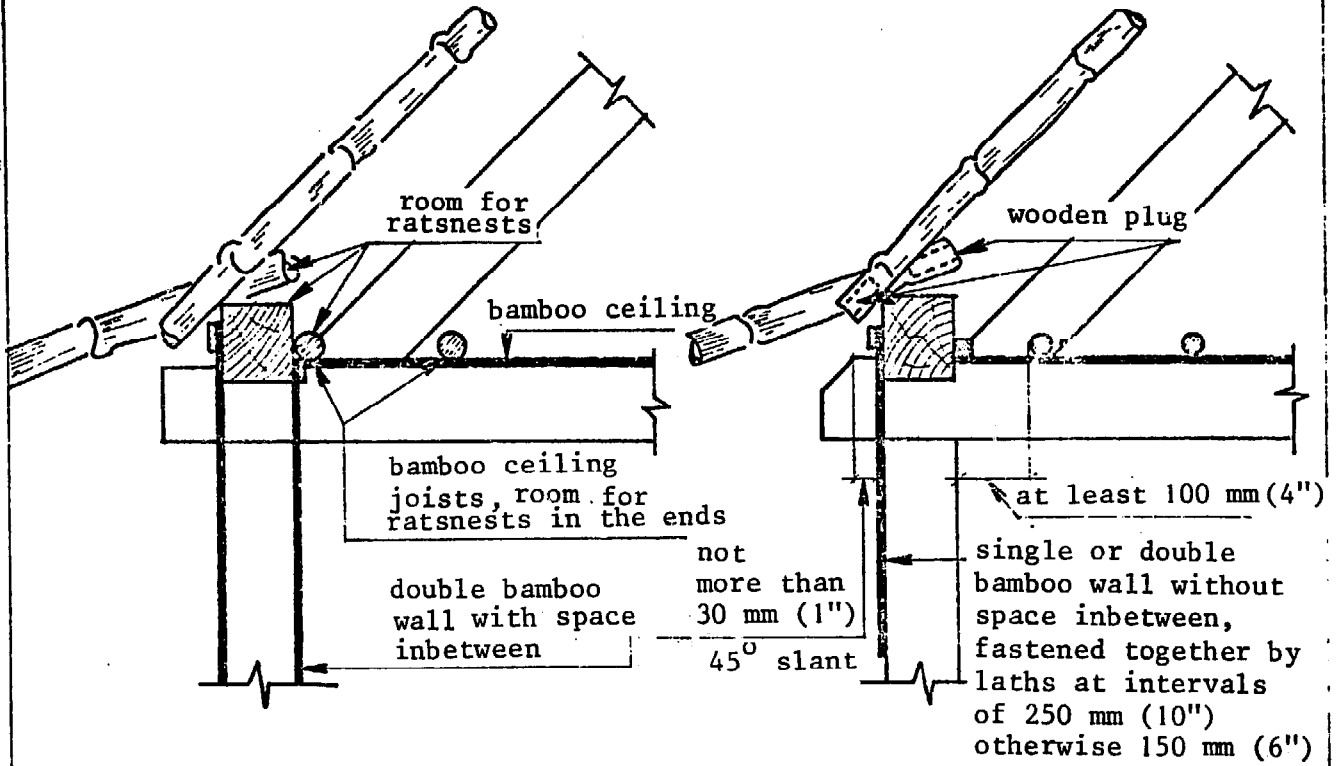
The first detail drawing shows a cross section of a ridge purlin that can also be used for a hip. It is clear that in case of a faulty construction the horizontal top surface of the ridge purlin is an ideal place for rats to nest. The mortar shown under the rafters is not used over the full length of the ridge purlin and has fallen through the roof tiles while completing the roof at the top. This mortar, covered by ridge tiles, is usually of such a bad quality that rats have no problems making holes and passage ways in which they can nest and have access to the hollow bamboos.

To solve these problems, the ridge purlin is placed in such a way that the edge points upwards and the bamboos are sealed by nailing well-fitting wooden plugs into the ends and the ridge tiles are placed directly on the top tiles.

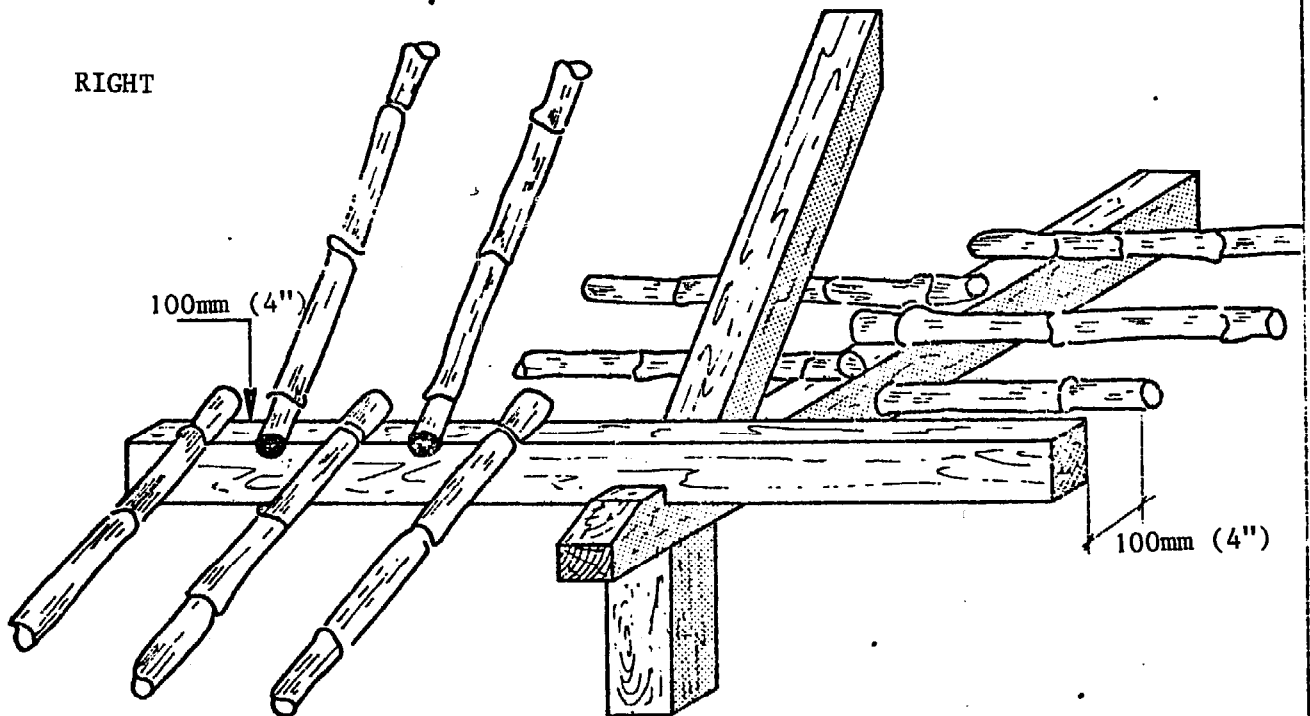
Mortar may be put on the ridge tiles to prevent them from being blown off. In order to be easily inspected, the rafters must be at least 50 mm (2") thick and not more than 50 mm (2") wide. The distance between the top side of the ridge purlin and the bottom of the ridge tiles must measure at least 100 mm (4"). The rafters meeting at the ridge purlin or hip must end against each other and not next to each other in order to facilitate inspection. Furthermore, whitewashing of the ridge purlin itself and the inside roof surface of at least 750 mm (2'6") on both sides of the ridge will make it difficult for the rats to nest without being seen.

WRONG

RIGHT



RIGHT



Side_purlin

This construction concerns the transition of a given roof slope to a slope that is less steep. The open, hollow rafters and the ceiling joists, the space between the double bamboo walls and the space along the first ceiling joist alongside the side purlin, are very dangerous and faulty constructions, because there appears to be no suitable solution for the connection.

Also the end of the binder protruding from the wall provides an opportunity for nesting. The horizontal top surfaces of the side purlin can be maintained if the ceiling can be walked on in order to make inspection of the side purlin possible.

In the process of improvement the ends of the hollow rafters should be sealed by well fitting, nailed wooden plugs.

In case of the double bamboo wall it should be made sure that there is no cavity.

The two bamboo layers should therefore be fitted closely together over the whole area. In case of the walls being fastened by sticks the distance between the sticks should not exceed 250 mm (10").

When fastened in any other way, the distance should not exceed 150 mm (6").

The first ceiling joist should be placed at least 100 mm (4") from the side purlin in order to make nesting impossible.

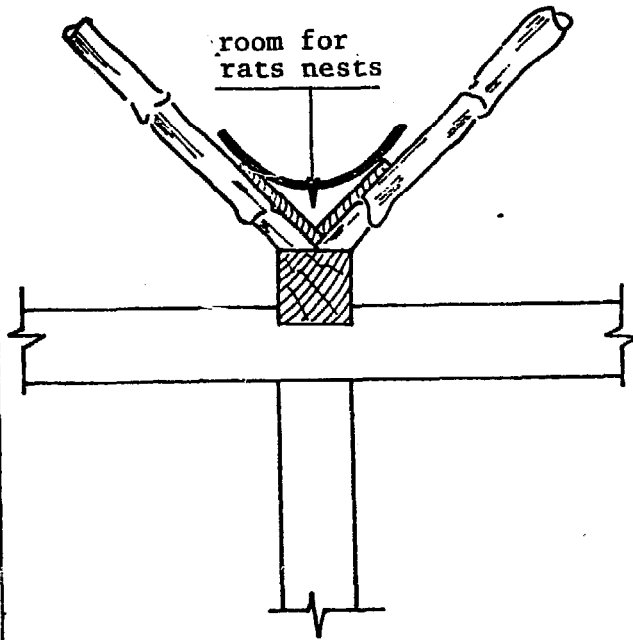
The ceiling can be fastened to the side purlin by securely fitted laths. The top side of the binder should not protrude from the wall for more than 30 mm (1"). If the binders protrude more, they should be sawn off at an angle of 45°.

If the space above the ceiling cannot be reached, the side purlin should be sawn off to a slant of 35°.

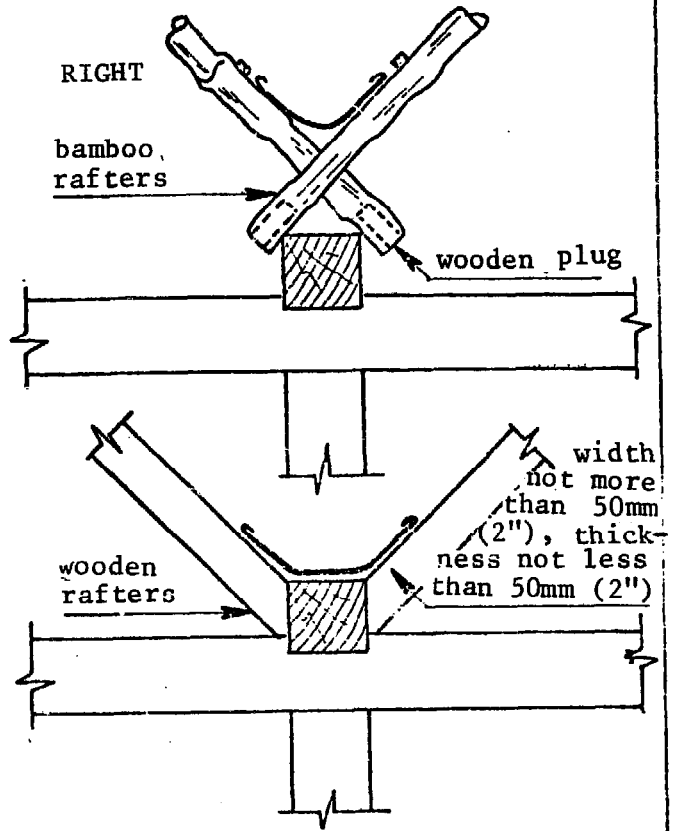
3

TROUGH GUTTER

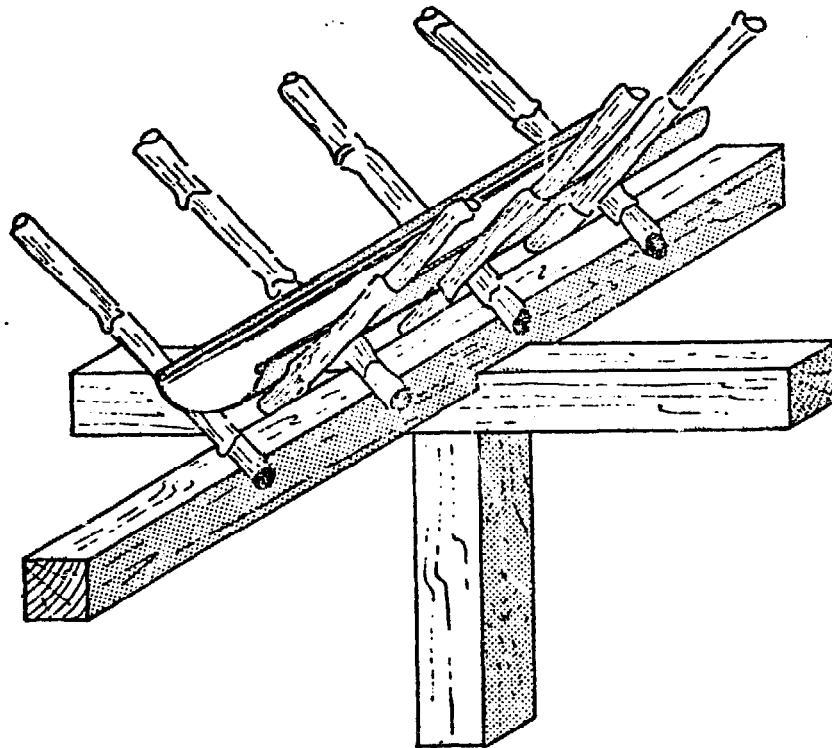
WRONG



RIGHT



RIGHT



Trough_gutter

This construction applies to trough as well as valley gutters. The gutters concerned occur when two roof surfaces meet. The trough gutter is horizontal and the valley gutter has a slope. When the gutter boards are placed in the wrong way, rats have an excellent opportunity for nesting under the zinc gutter.

In addition the hollow bamboos that are usually not connected properly to the gutter purlin or the valley are dangerous.

Improvement can be achieved in two ways:

the top figure applies to bamboo as well as wooden rafters, the middle figure to wooden rafters only. When using bamboo rafters these should be carefully sealed by well fitting, nailed wooden plugs.

It is obvious that the improved construction provides an adequate means of inspection.

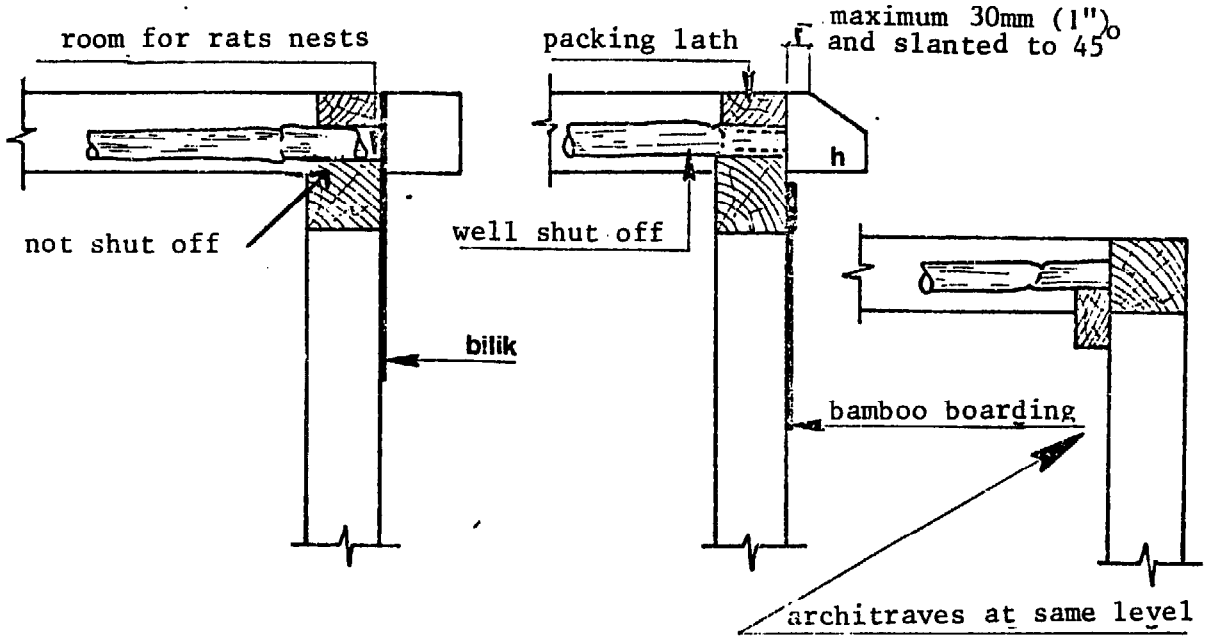
The middle figure applies to wooden rafters only because the ends would not be visible anymore.

The side surfaces of the roof should be whitewashed over a width of at least 750 mm (2'6") on both sides of the valley, for better rat control as these places are usually rather dark.

WRONG

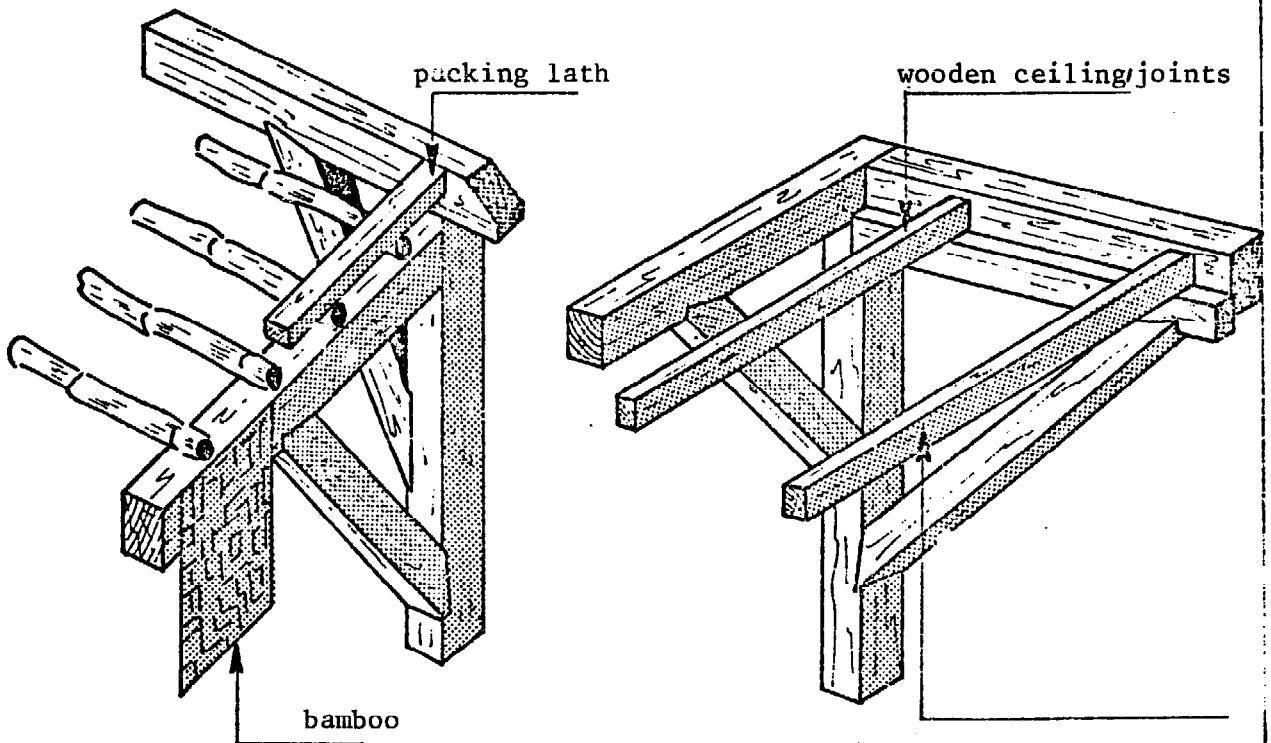
RIGHT

architraves not at same level



architraves; not at same level

architraves at same level



Corner assembling of architraves (1)

In many houses we find architraves that do not have the same height. The ceiling joists are placed on the lower architrave and the difference is made up by a packing lath that supports the rafters on the same level as the top architrave.

It is clear that when the bamboo wall goes as far as this lath, there is a space between this lath and the lower architrave, where rats can stay unnoticed, as even the ends of the bamboo ceiling joists can not be inspected. In the improved version the bamboo wall ends at the lower architrave.

Now the ends of the ceiling joists, securely sealed off by well fitting wooden plugs, are clearly visible.

If one of the architraves protrudes the other, then the requirement counts that the top surface must not project more than 30 mm (1") horizontally; if more, then this should be given a slant of 45°.

In better houses we see architraves at the same level. The ceiling joists are then placed on a separate load-bearing beam. There is no objection to this as long as the ceiling joists are wooden ones. If they are of bamboo, they should be placed on the architrave themselves in order to be able to inspect them.

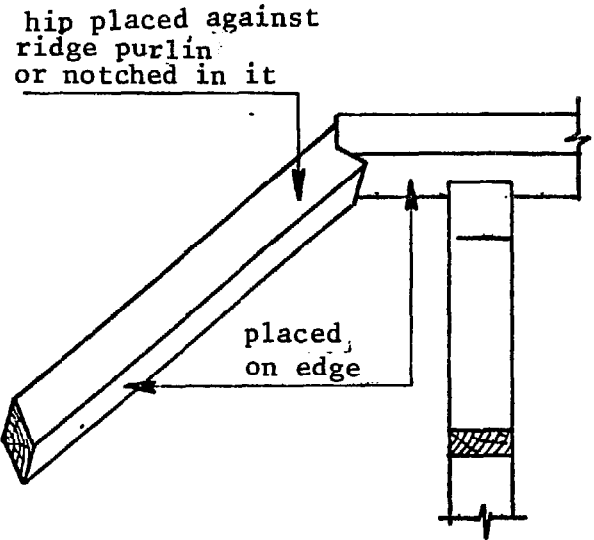
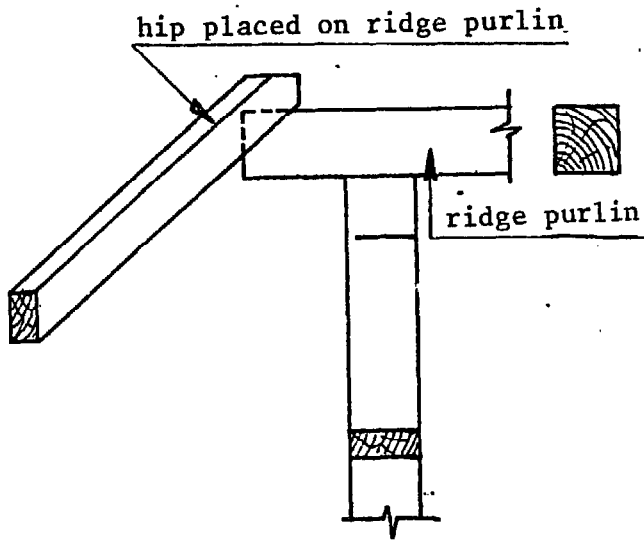
- (1) Architrave= that lower part of a roof structure which rests immediately on the column.

5

HIP CONNECTION

WRONG

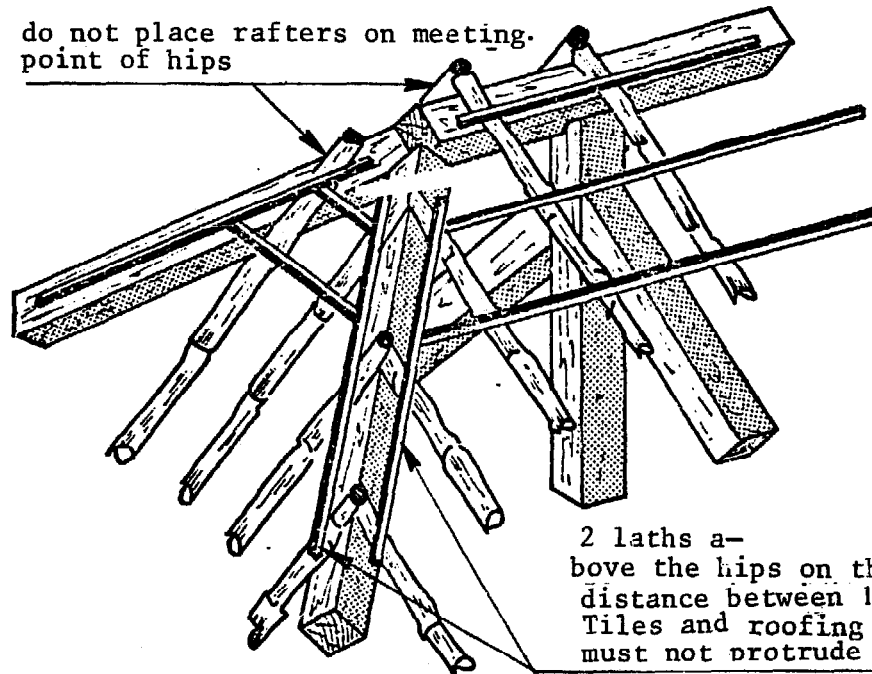
RIGHT



hips notched in ridge purlin

do not place rafters on meeting-point of hips

RIGHT



Hip connection

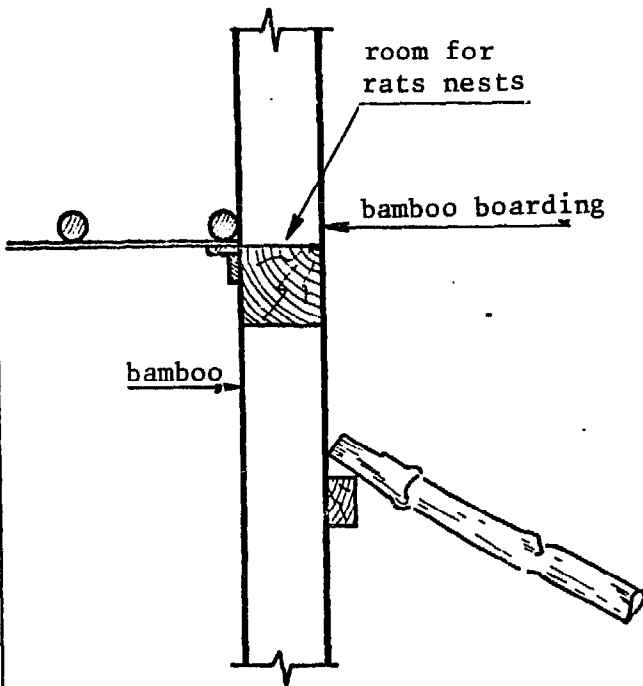
Quite often the hips of houses are placed on the ridge. It is quite obvious that this situation gives rats a grand opportunity to make nests unseen. That is why the hips should be placed against the ridge or notched in it. There is a special precaution that must be taken into account, concerning the rafters. They may not be placed in such a way that they meet each other in the same point as do the hips and the ridge. This point where hips and ridge meet each other must be kept clear in favour of visibility.

Furthermore a few laths should be placed at 100 mm (4") interval above the hips on the rafters. The roofing battens and the tiles of the adjoining roof surfaces may not protrude inside this area between the two laths so as not to interfere with visibility. The tiles should be shaped so as to follow the angle.

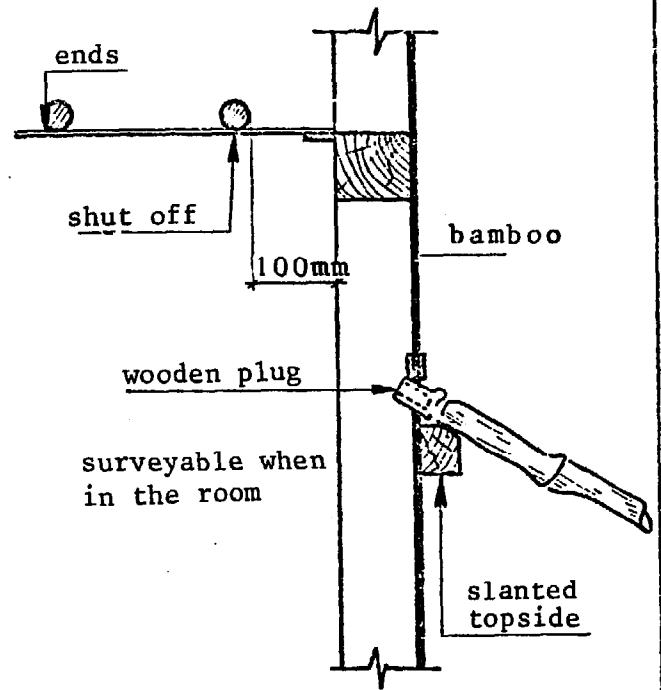
6

DOUBLE PITCH ROOF
(porch or veranda)

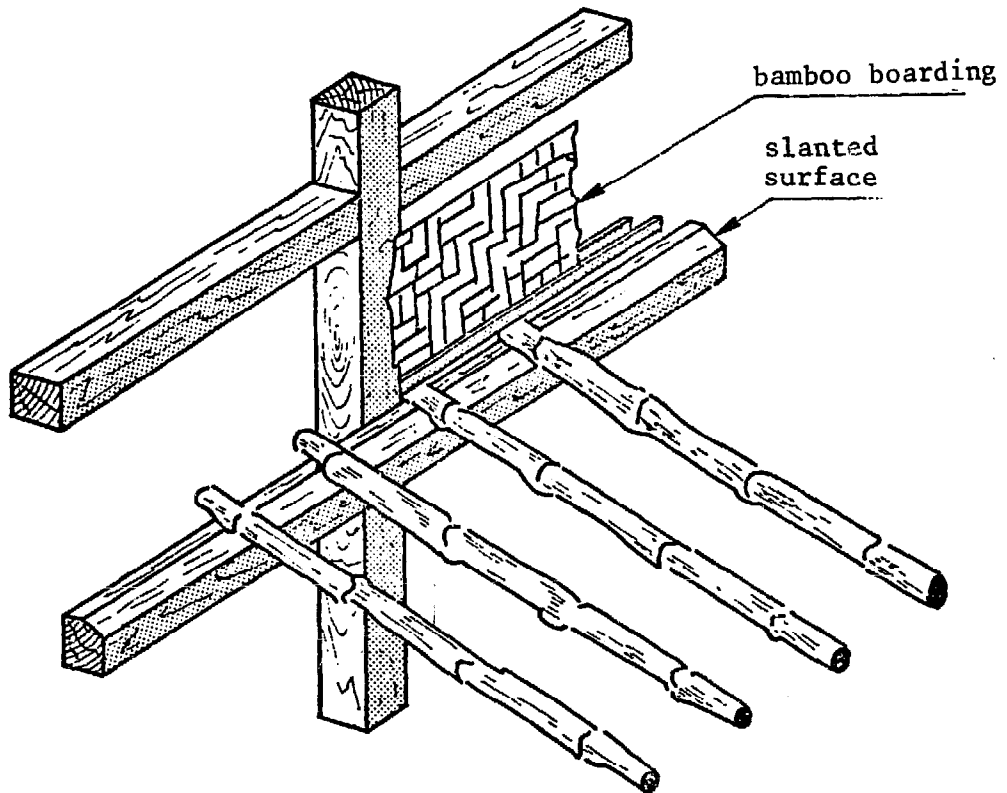
WRONG



RIGHT



RIGHT



A lean to or single pitch roof

The annex of a simple dwelling is usually covered by a single pitch roof.

In present constructions open hollow bamboo's are used as rafters, supported by a beam, and often against a double bamboo-wall with space in between so that the ends of the hollow bamboo's are not visible at all.

The improvement takes place by replacing the double bamboo wall by a single one or a double one that is made of two layers closely fitted together and by interrupting the wall where the ends of the rafters are. The hollow bamboos that have been shut off by well fitting nailed plugs, can easily be inspected when being in the living room.

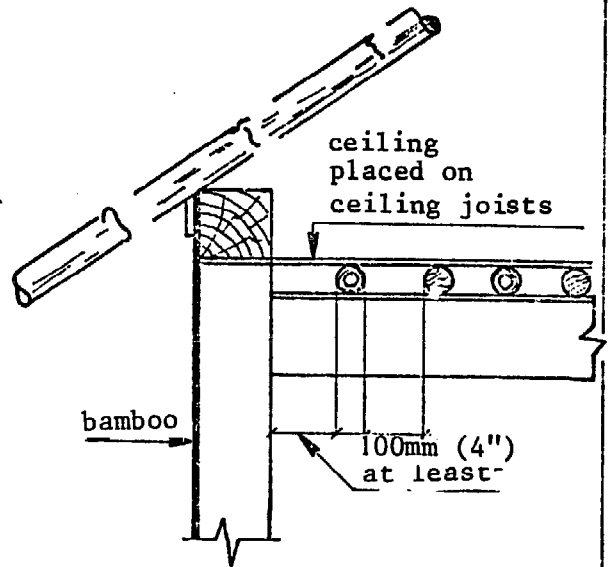
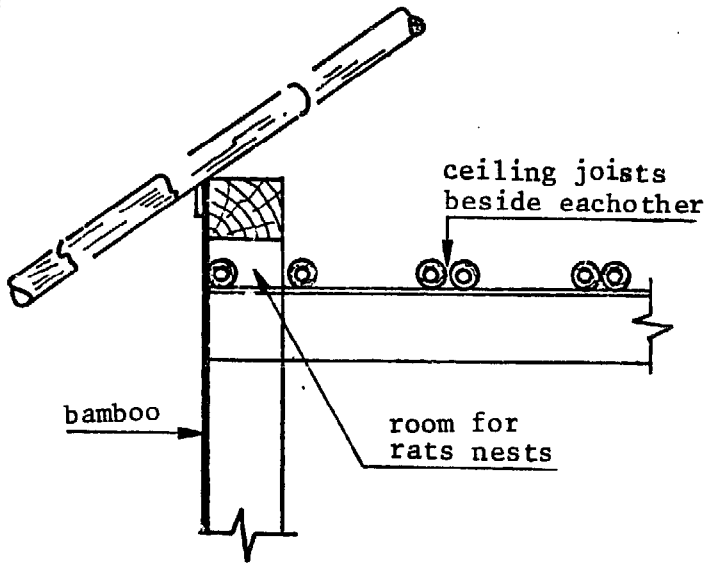
The beam on which the rafters rest should be slanted, because a horizontal top surface gives opportunity to making nests unnoticed.

7

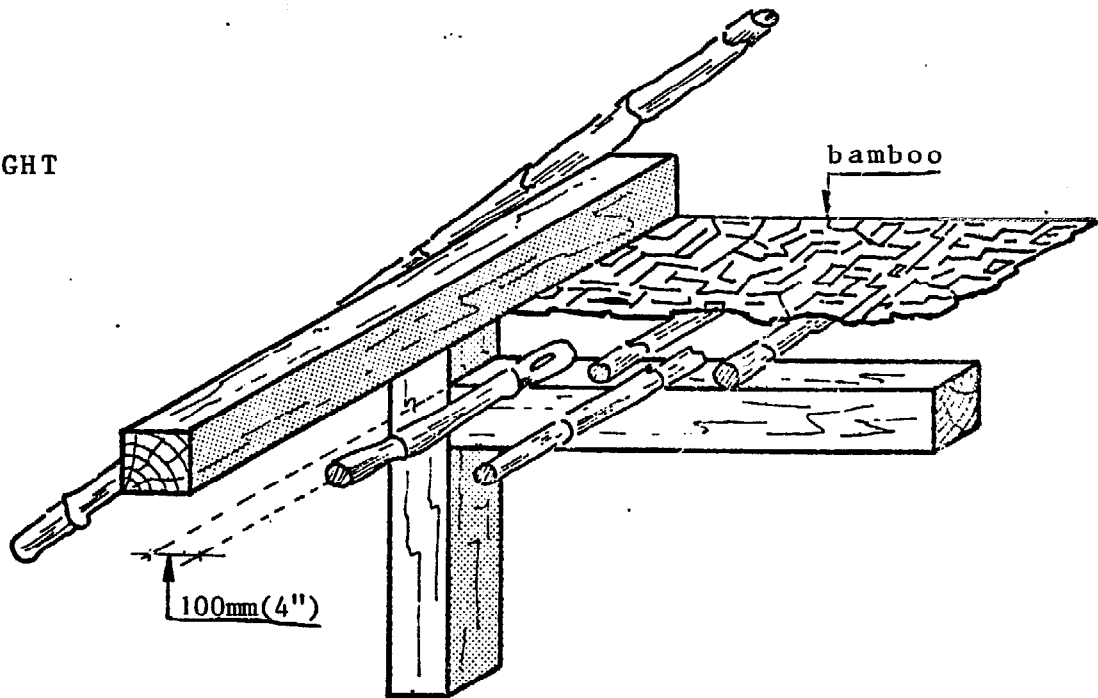
CEILING

WRONG

RIGHT



RIGHT



bottom of architrave is higher than top of beam

Ceilings

Ceilings that cover a whole room are allowed if they can not be penetrated by fleas and are also connected to the walls for this purpose. Furthermore we are to have a manhole size 500 x 500 mm (20"x 20") that can be shut well and the ceiling hanger must be strong enough to bear an adult person.

Ceilings, that do not cover the whole room, do not have to be unpenetratably by fleas. The danger of having rats nests in the room above the ceiling is much less than.

Furthermore we must take care to place the first ceiling joist at least 100 mm (4") away from the architrave, while the ceiling joists are placed at least 100 mm (4") from each other on the beam where they meet each other, so as to avoid lodges that are very difficult to check.

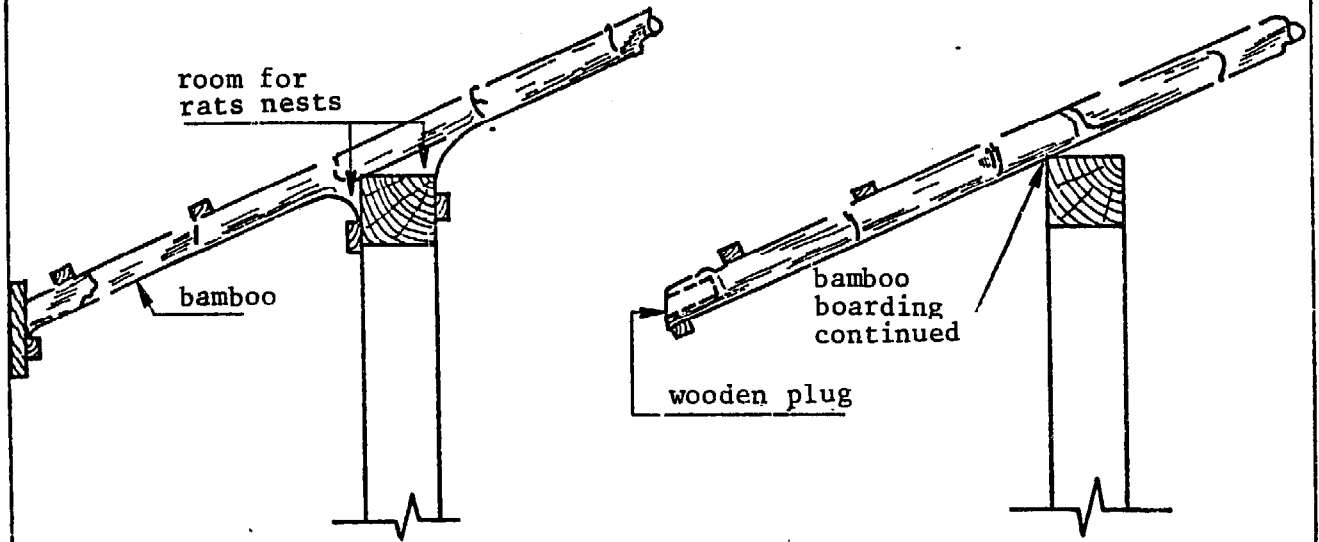
It sometimes happens that the bottom of the architrave is higher than the top of the beam.

If this difference in height is rather small, let us say less than 100 mm (4") and the ceiling is in this case fastened under the ceiling joists then the space between the ceiling and the bottom of the architrave is not very easy to see.

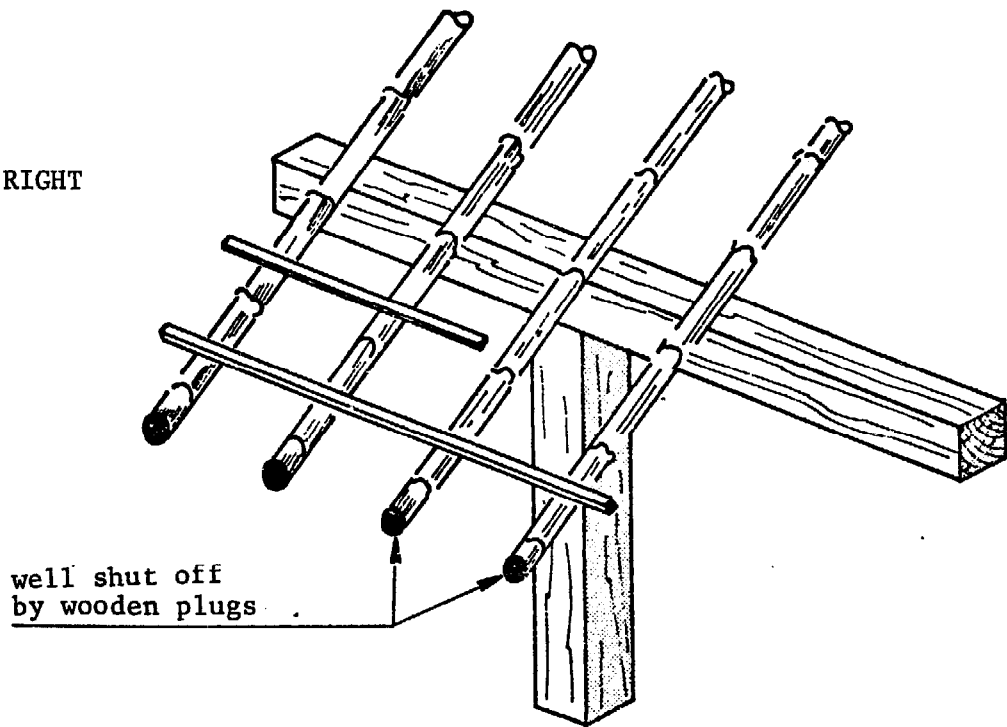
When improving, the ceiling is placed on top of the ceiling joists, so that the space mentioned disappears. If the bottom of the architrave is 100 mm (4") or more higher than the top of the beam then the ceiling may stay fastened under the ceiling joists without any danger.

WRONG

RIGHT



RIGHT



Roof boarding

A roof boarding that covers a whole roof surface should be able to withstand penetration of fleas and therefore also be properly connected to walls in a clear way. This is hardly the case in the present situation.

Like the wrong construction shows us the space between the architrave, the roof boarding and the tiles is not very surveyable.

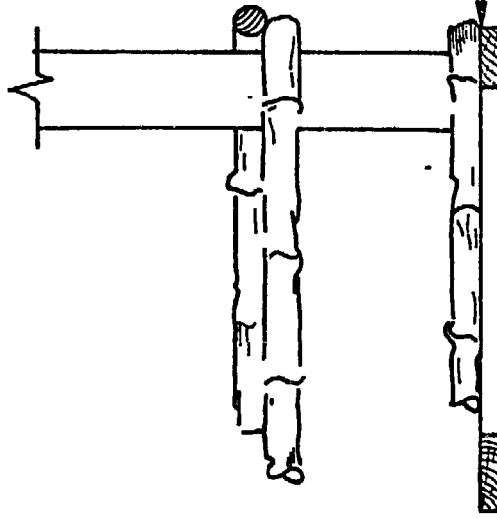
It is furthermore not preferable to put a board against the ends of the hollow bamboo's, because this takes away visibility.

Improvement can be achieved by continuing the roof boarding over the architrave so that the space, otherwise not surveyable disappears, and by leaving out the flashing boards, the ends of the rafters that have been shut off by well fitting wooden plugs, are clearly visible now.

The space between the roof boarding and the tiles can of course only be inspected when the top end of the roof surface is solved as shown in the improved construction 2 or 6.

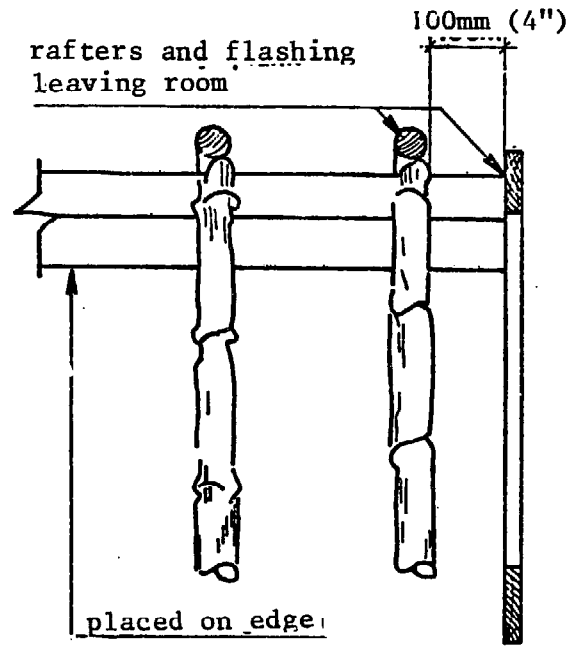
WRONG

rafters and flashing
connected together



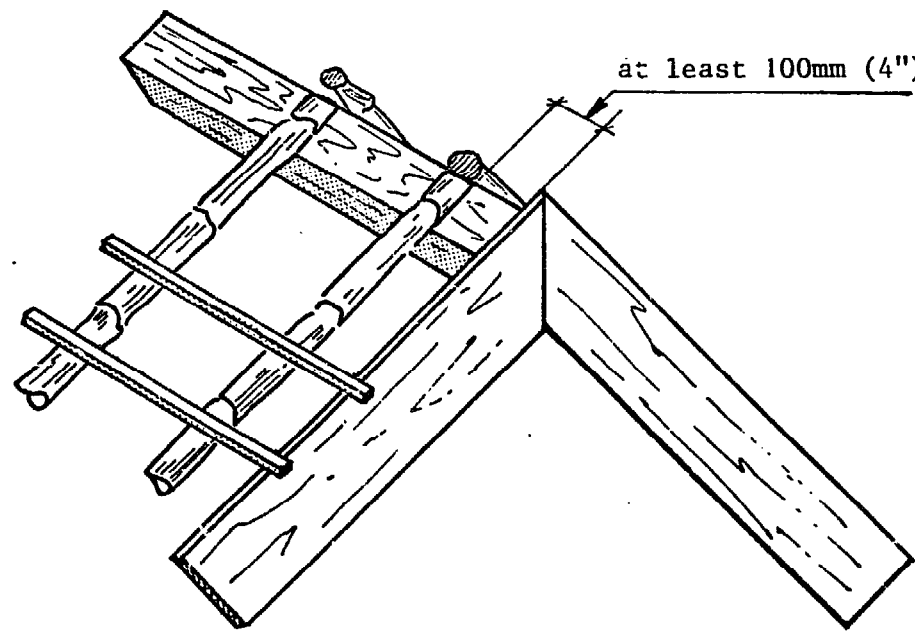
RIGHT

rafters and flashing
leaving room



RIGHT

at least 100mm (4")



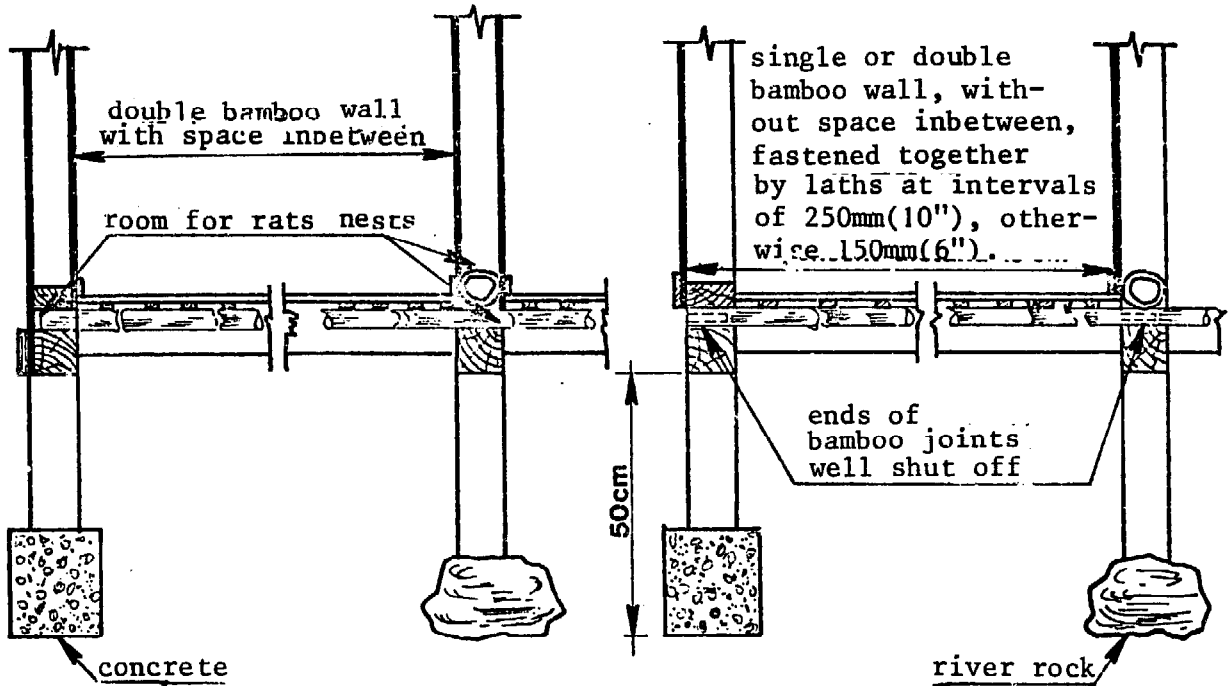
Ridge_ending

In case of a double pitch roof roofsurfaces are ended by flashing boards that are connected to the end of the ridge beam.

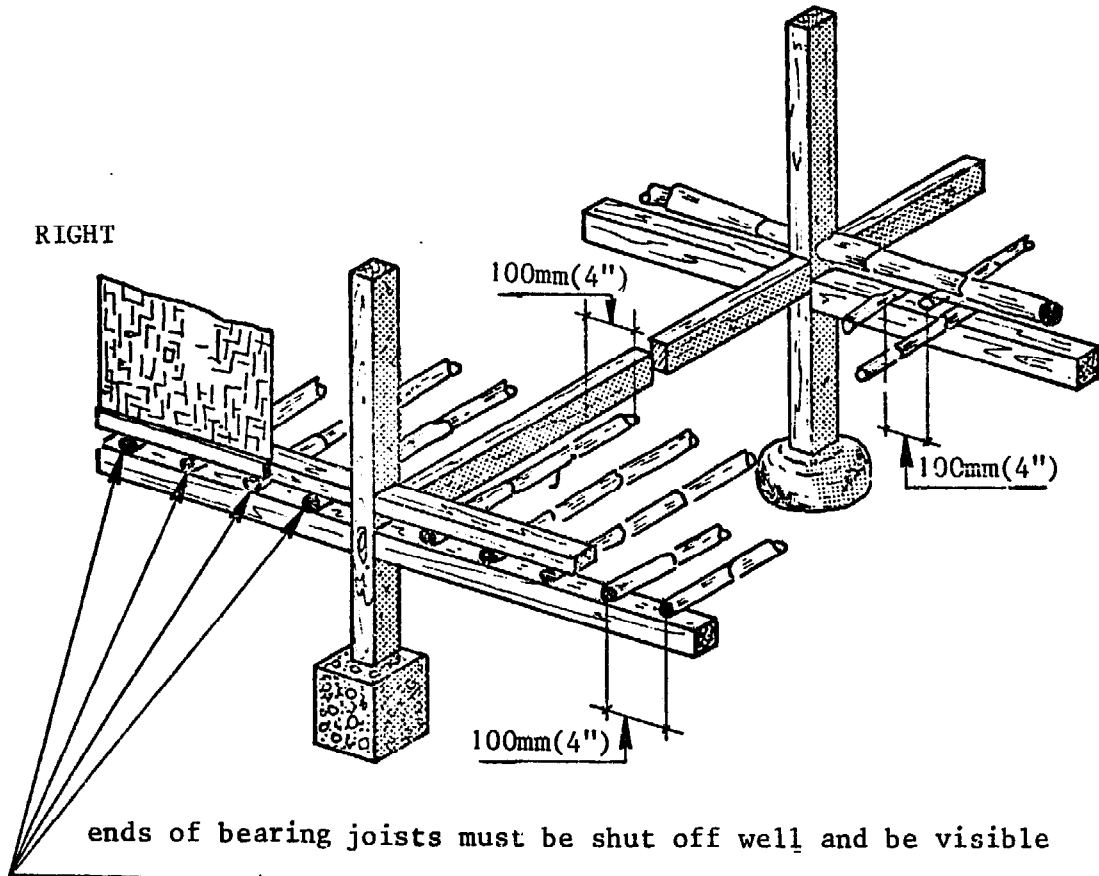
If the rafters are placed directly against these boards, the visibility is very difficult; that is why these last rafters should be placed at least 100 mm (4") away from the boards when improving.

WRONG

RIGHT



RIGHT



Bamboo floors on top of basement

The wrong construction shows that it is necessary to have plenty of room between the floor and groundlevel outside, especially to inspect the floor joists. That is why the distance between the joists and groundlevel should be at least 500 mm (20").

Lower floors with a minimum of 350 mm (14") are acceptable if it is possible to take away the floor covering and beams entirely or partly. In any case it should be easy to get rid of fleas etc.

If the bamboo walls continue past the bamboo bearing joists then rats will have the opportunity to make nests unseen there. That is why the bamboo walls should end above the bearing joists so there is no hidden space anymore and the ends of the bamboo bearing joists that are shut off by well fitting nailed wooden plugs, can easily be inspected.

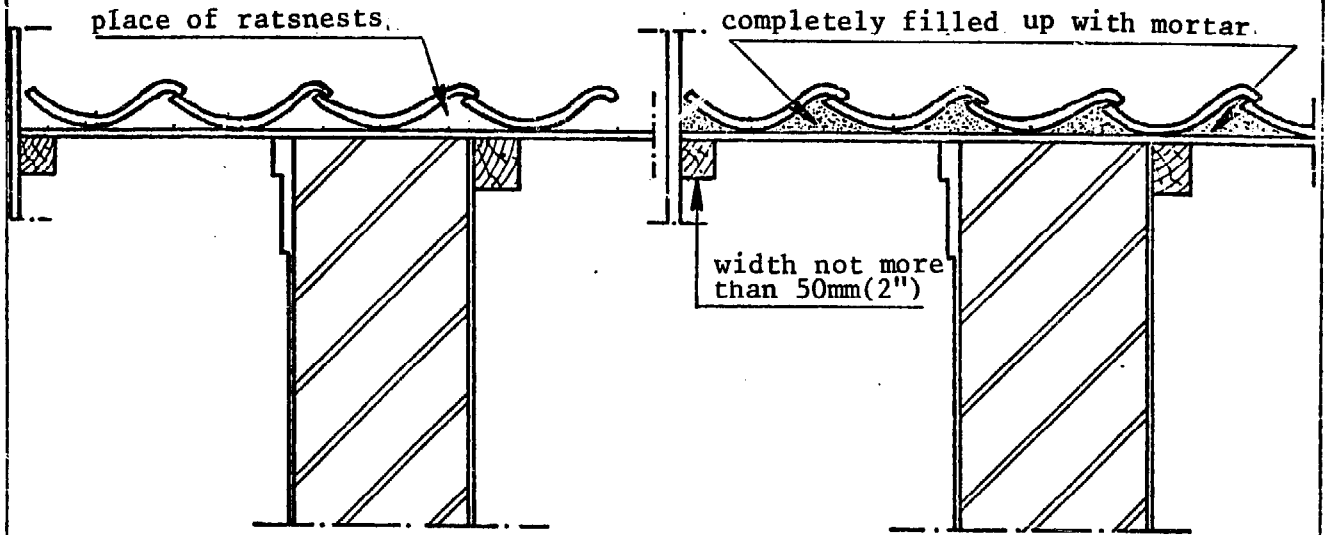
Also for the sake of surveyability the bamboo bearing joists meeting each other on the beam should be kept at least 100 mm (4") apart from each other.

A

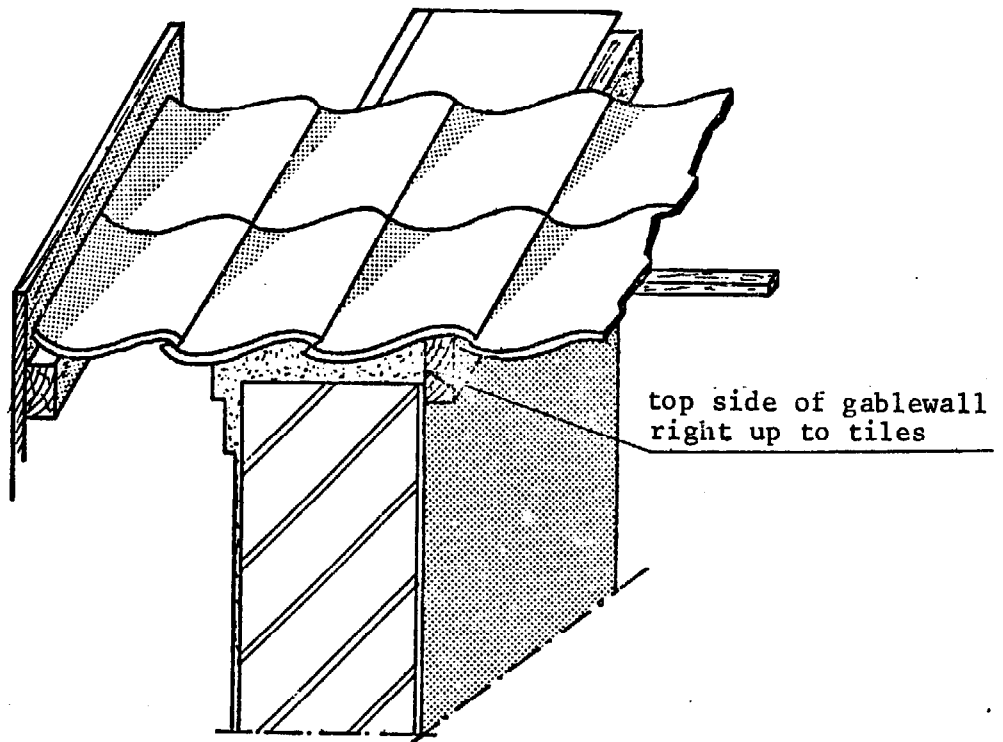
GABLE WALL

WRONG

RIGHT



RIGHT



The following constructions concern better houses built of more permanent material.

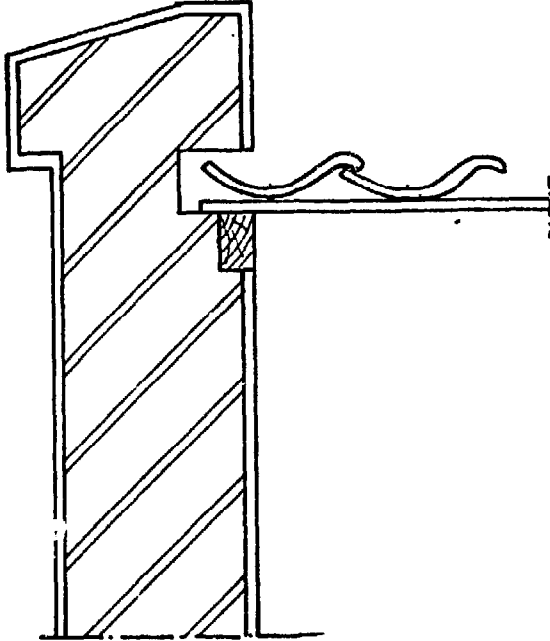
Gable wall

If a roof surface protrudes a gable wall then the space between tiles and wall offers rats enough opportunity to make nests unnoticed. That is why this space must be entirely filled up with mortar. This also counts for inside walls unless they leave 200 mm (8") or more room over under the roof.

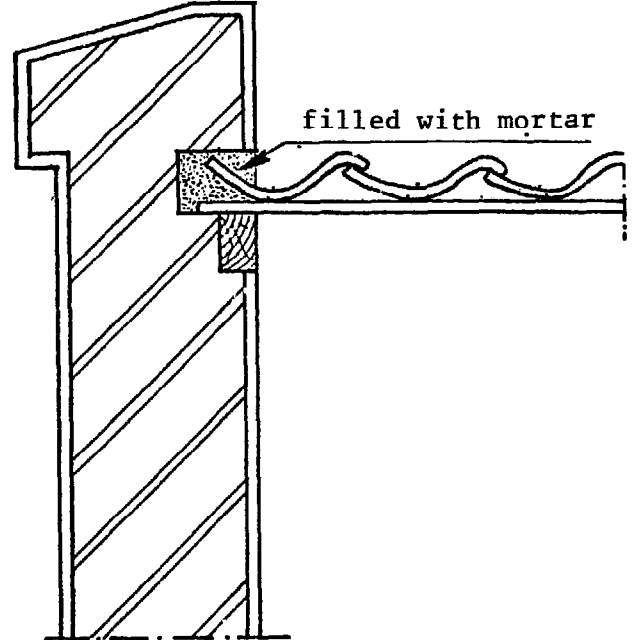
B

CONNECTION OF ROOF SURFACE
WITH WALL

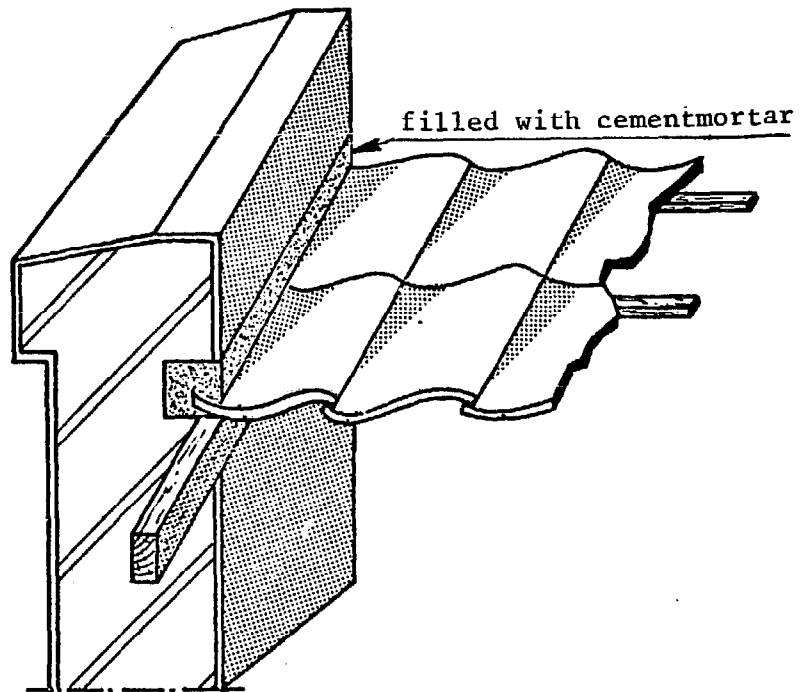
WRONG



RIGHT



RIGHT



Connection of roof surface against wall:

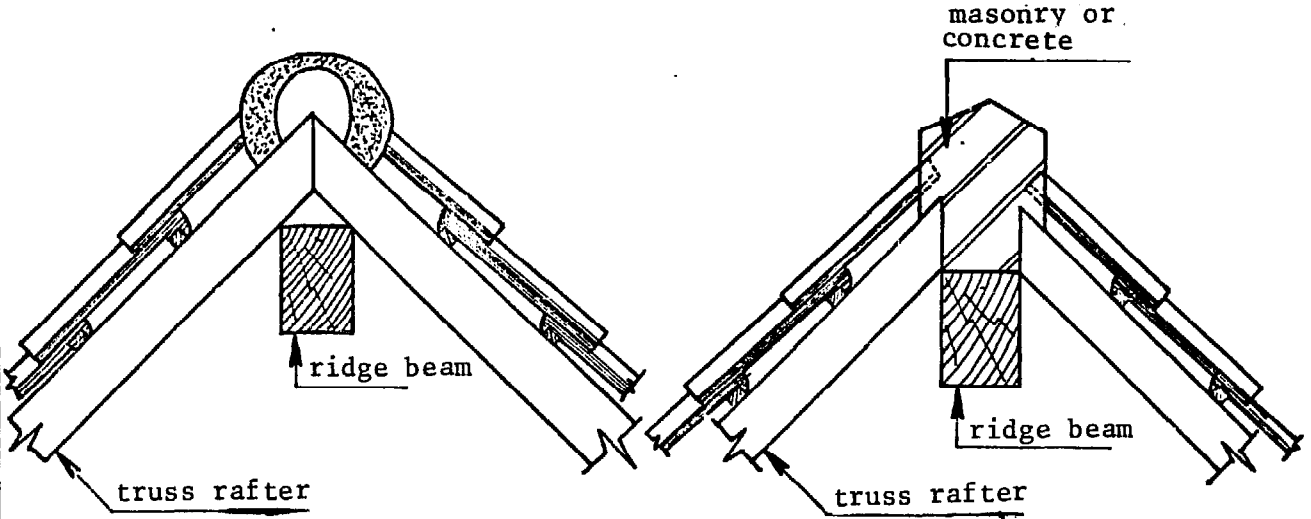
If a roof surface ends against a wall then the last rafters and tiles should end in a groove in the wall. This groove makes rats nests possible so it must be filled with mortar.

C

RIDGE

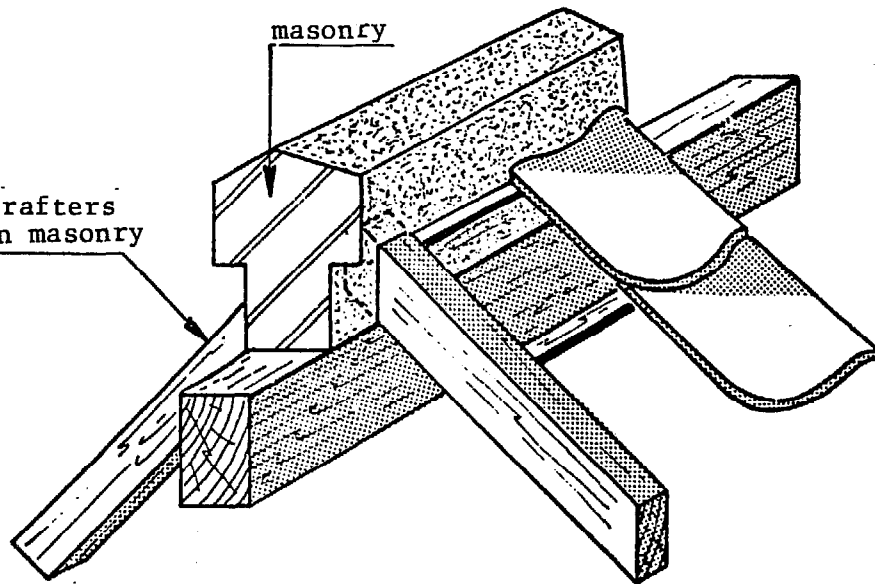
WRONG

RIGHT



RIGHT

ends of wooden rafters stuck in masonry



Ridge

When the fault ridge construction (top side ridge horizontal) is found in better houses, then it can be improved by making it slanted on both sides. But normally it will be easier to fill it with masonry or concrete.

2.6.

BUILDING WITH BAMBOO ')

A solution to the housing problem in Colombia - by D.Castro
From : Bouw 30 (1959) pag. 850-853.
Translated from the Dutch by L.M.L.Booth.

Colombia lies at the very centre of the American continent and this favourable geographical situation offers great opportunities for future development of the country.

The start of an air line in 1920 heralded a new era of awakening after a long period of sleep lasting for nearly four centuries. Air transport enables the population of Colombia to communicate with all parts of the country and improves the chances of general development.

However, the new Colombia flourishes with the exuberance of a tropical plant and has to face the risks inherent to such rapid growth.

In this land of contrasts transport uses aircraft and mules, the very rich next to the very poor, indian women weave blankets in the traditional manner and machines produce consumer goods at mass production rate. Cold mountainous regions alternate with wide, very hot plains and the gaiety of the negro stands out against the sombre outlook of the indian population.

The problem of living, working, education and relaxation create an urgent need for building. Roads are needed too, in order to build more rapidly and economically and thus enable the country to develop.

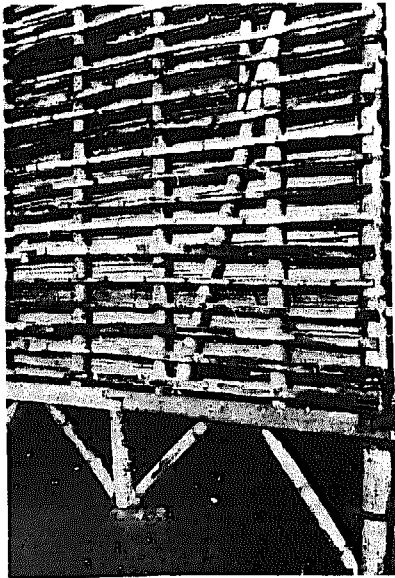
Very impressive buildings go up, but they do not solve very any of the real building problems. Building exclusively for tourist attraction may produce some original and colourful construction but it hardly helps towards finding a truly valid solution for the situation as a whole

Quite often, town planners make decisions without being aware of the existing problems. For instance, no real answer has been found to questions such as : where to build, for whom, with which materials ? etc. etc. Moreover, not sufficient thought is given to future social changes what may effect town planning.

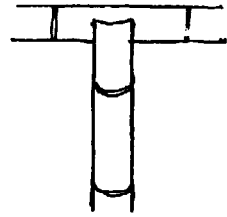
As a result, so-called solutions have to be abandoned before they have been put into practice or changes have to be made while the actual building is still in progress.

Whenever this happens, large amounts of money have already been spent and are, therefore, wasted.

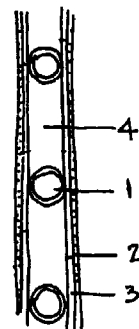
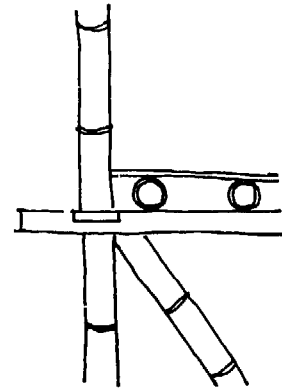
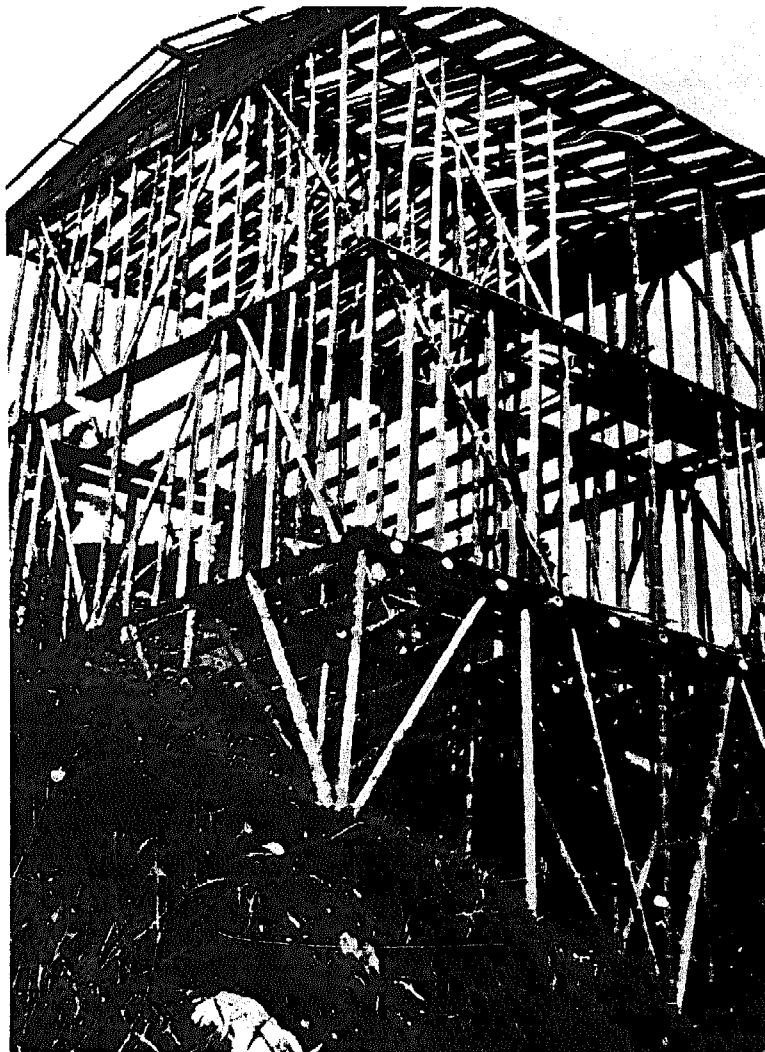
') By courtesy of the Building Research Establishment, U.K. and the editor of the Dutch journal "Bouw".



1. Foundation detail, the bearing poles rest on individual stones.
2. Top view of bamboo connection.
3. Front view of bamboo connection.
4. Horizontal section of bamboo wall. 1.pillar; 2.rendering; 3.split bamboo; 4.air space.
5. Corner joint between wall and floor.
6. Frame of bamboo house. The "balloon frame" construction is quite clear.



1 2
3
4
6 5



Building methods of the Colombians

In trying to solve the housing shortage in Colombia, existing traditional methods of construction must not be neglected. It is necessary to study these methods and try to adapt them to present-day needs. As a relevant point, let us consider the type of bamboo construction that is used locally by people without enough money to call in professional help but would still wish to live in their own house.

In the country and in the smaller towns of the province of Caldas, ordinary middle-class people, quite unskilled, solve their own housing problems by building houses of bamboo. These houses are very light and need only shallow foundations. In the case of bungalows, it may be sufficient to have one single foundation stone under each bearing bamboo pole.

The vertical structure consists of bamboo poles spaced at 30 to 50 cm interval and connected diagonally by other bamboo poles, in order to take up the horizontal forces, e.g. wind loads.

The construction is similar to the "balloon-frame" type of construction that has been used in the U.S.A. for many years with great success and owes its name to the fact that it is extremely light. Because of the flexibility of the structure, the house will react elastically to changes in shape which prevents damage.

Floors are made of a wood with less flexibility than bamboo, unless the owner finds the cost too high and uses split bamboo. The roof structure, covered with Spanish roof tiles has a frame of thin bamboo.

The walls are made of split bamboo ; they have an inner and an outer layer with an air space in between, providing adequate thermal insulation and protection against damp. (note: see page 38 and 39 !)

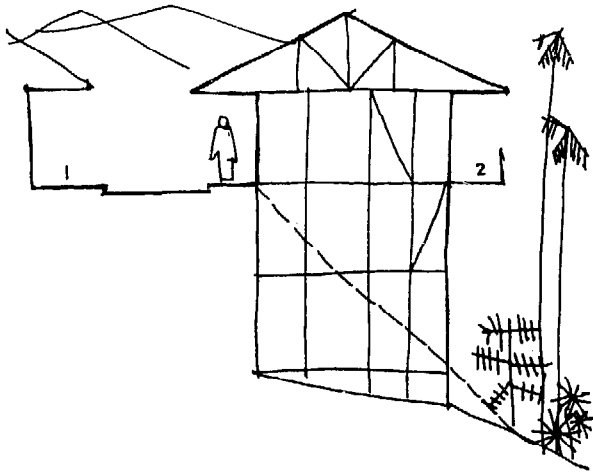
This type of construction protects the inside of the house against the sudden changes of temperature that are common in Caldas.

On the outside, the walls are covered with a mixture of earth, dung and grass cut into small pieces.

The front door is left open all day, which takes care of ventilation and lighting. During the night, the small windows provided in the door remain open to ensure sufficient ventilation.

The roof overhangs the house very considerably and affords good protection against sun and rain. It is agreeable to walk through streets lined with these houses, because the overhanging roofs provide shade and shelter.

A bamboo house that has been kept dry during the building process will last for about 25 years without requiring any structural repairs. The local population is convinced that the bamboo must be at a given phase of the moon if it is not to rot rapidly.

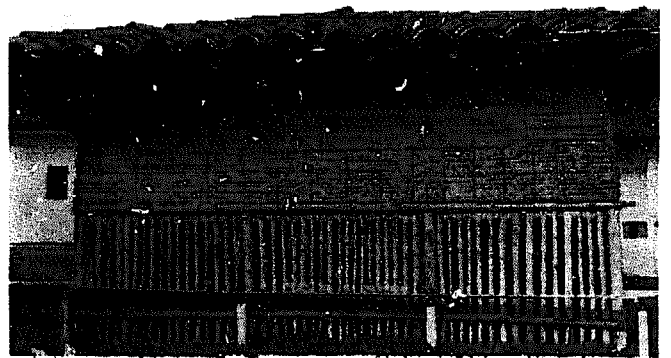
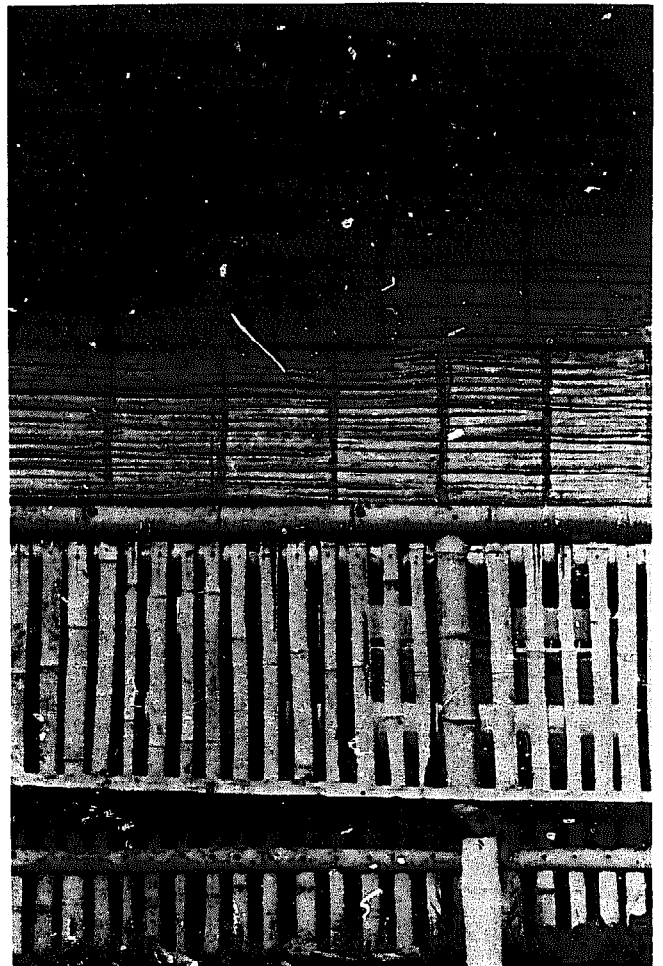
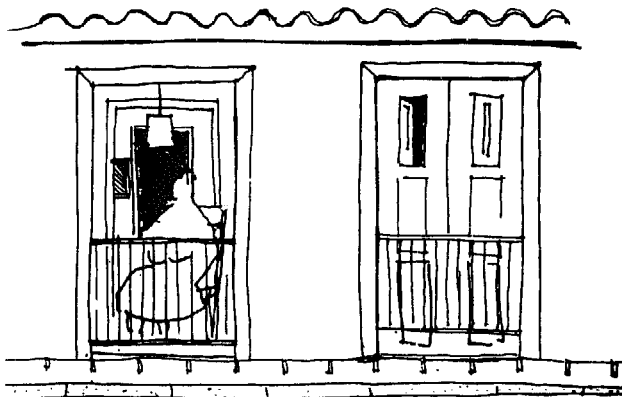
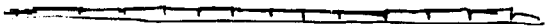


7 8

9

11 10

- 7. Section of bamboo house built on sloping ground. 1.street;2.balcony.
- 8. Part of wall made of split bamboo.
- 9. Roof structure with Spanish tiles.
- 10. Unfinished bamboo house on sloping ground.
- 11. Door with windows.



Houses built on piles

On sloping ground houses are built on piles, far above ground level. But even on flat sites the bearing poles always extend a few inches above the ground to prevent damage from dampness in case of excessive rainfall.

Building high has the advantage of giving a good view of the surrounding landscape.

Bamboo construction as applied in Caldas has many advantages, a few of which are listed below.

The use of one type of material gives unity and continuity in spite of differences in design and colour. The inhabitants can give a free rein to their imagination and express themselves in the painting of their houses without disrupting the unity of the whole.

Another great advantage is the low cost compared to other kinds of building. As a result, many people are able to own their house. Costs are low because the bamboo is cheap and the inhabitants can build the house by themselves.

A further advantage is the relatively short life of 30 to 40 years which means that the house is amortized within the actual time of occupation. Brick houses have a life of about 100 years but this is a disadvantage from the economic point of view.

A married couple occupies a house as soon as it is built. Children are born and educated there and leave the house after 20 to 25 years to found new families.

After 30 to 40 years, when the parents are dead, the bamboo house is worn out and finished, which is a good thing because the younger people want something new with all modern conveniences and not a house that is 40 years old or more.

Contrary to what happens in the case of brick houses, the owners pay a price based on the real life of the house (about 40 years) which corresponds to the time of occupation.

With brick houses there is the risk of having to amortize over 40 years a house that will last a hundred years and that will not be very attractive to other occupants.

In other words, care should be taken that a house should not lose its value before it is technically worn out.

This does not mean that bamboo houses are ideal and that there is no room for improvement.

Expert advice needed

Internal lay-out has been sadly neglected. Rooms are put together without any previous consideration about the best way of grouping them. In many cases, for instance, the children's bedroom is separated from the living room by the parent's bedroom. The parent's siesta is interrupted by the children running from the living room into their bedroom and back again.



12. Various applications of bamboo and some phases of the construction process are illustrated in this view of a row of bamboo houses.

13. The street is a meeting place; overhanging roofs give protection against sun and rain.

12

13



There is much scope for improvement as regards lighting, ventilation and hygiene.

It would certainly not be a luxury to call expert advice on design and execution in order to get better and cheaper houses. Caution is needed in this respect, however.

The introduction of new methods and materials without a thorough investigation of the possible effects on local population would be quite wrong.

Using glass, for instance, where before there were only openings, may give better protection against changes of temperature but will break the direct contact with the outside. The house would no longer be part of the whole street and the spontaneous and intensive contact with the neighbours would stop.

Changes will have to be gradual. The population must have every opportunity to adapt itself, otherwise there is a danger of the innovations being wrongly used. Revolutionary changes would only worsen the lot of rural population of Colombia.

With suitable and careful advice from experts, it seems that bamboo construction could provide a good solution to the housing problem of large parts of Colombia.

The fact that the population itself would be so actively concerned with the solution is, in itself, an encouraging feature.

This does not mean that a similar solution would be right for every other country. Here again, a careful study of the many aspects of the problem is required, with strong emphasis on specific local conditions.

Fig. 220 (56). Bamboe-deurkozijn.

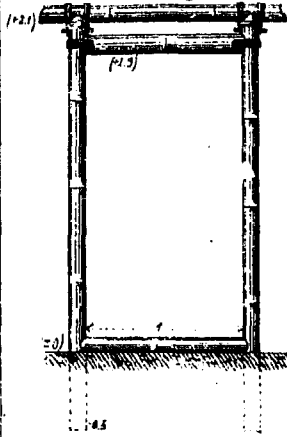


Fig. 221 (56). Bamboe-raamkozijn.

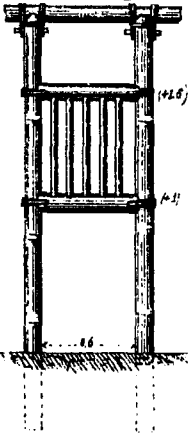


Fig. 222 (56). Bamboe-deur.

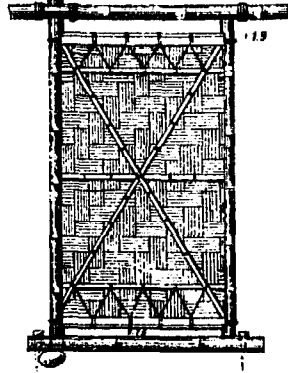


Fig. 222^a Andere inrichting draaipunt en bijzonderheid van het deurblad.

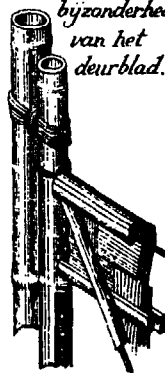


Fig. 222^a Bovendraaipunt der deur.

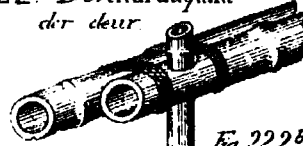


Fig. 223 (56). Bamboe-draairaam.

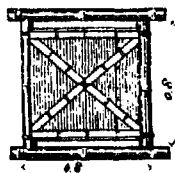


Fig. 224 (56). Bamboe-schuifraam.

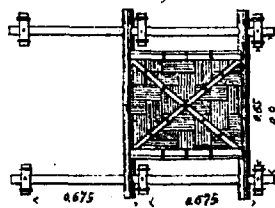


Fig. 222^b Onderdraaipunt der deur in een houten blok.

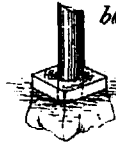


Fig. 222^b Andere inrichting draaipunt.



Fig. 225 (56). Raamsluiting.

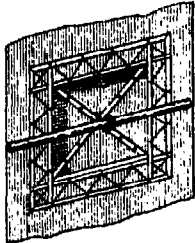


Fig. 226 (56). Deursluiting met palang pinloe.

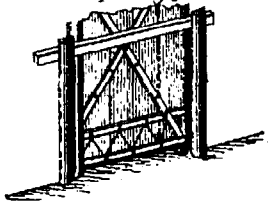


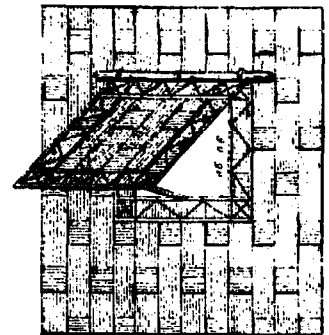
Fig. 227. Houten



Fig. 228. Ijzeren pen tot hangslot.

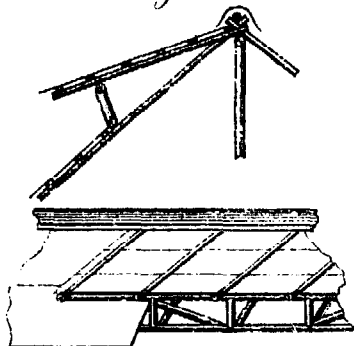


Fig. 219 (56) Klepman.



Nokventilatie door verhooging van een gedeelte van het dak.

Fig. 235



(56).

Fig. 236

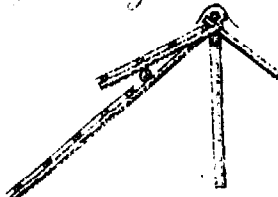


Fig. 234 (56) Nokventilatie door opening van den dachhoek boven den uitersten binnenhok.

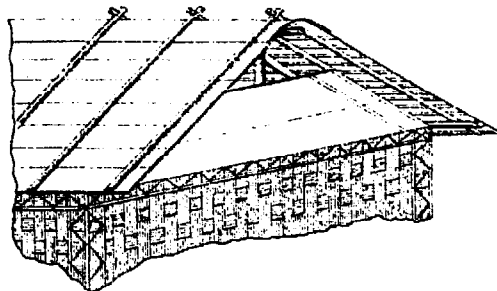
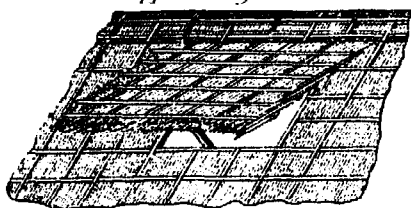


Fig. 237 (56). Nokventilatie door kleppen nabij den nok.



Doors and windows

Abstract from K. van der Maaten (1894)

- Fig. 219 Top hung window
- 220 Door-frame
- 221 Window-frame
- 222 Door with a-b-c : details
- 223 Turning window
- 224 Sliding window
- 225 Lock for window
- 226 Lock for door
- 227 Wooden and iron pin for padlock
- 235 } Opening in roof for fresh air
- 236 } Opening in roof for fresh air
- 237 } Opening in roof for fresh air
- 238 Opening in top of gable wall for fresh air.

More details on doors and windows can be found in the books by Dunkelberg and Hidalgo; see the references in chapter 9 in this book.

2.8. Tools

We close this chapter with a description of the tools, needed for bamboo-work. These pages have been taken from McClure, i.e. his pages 44, 45, 29 and 30.

Tool Requirements

Bamboo is notorious for its dulling effect on edged tools. This effect is due to the silica with which the tissues are more or less heavily impregnated. The effectiveness of edged tools will be maintained at a higher level, and the time consumed in sharpening will be greatly reduced, if tools made of molybdenum steel or an equally hard alloy can be secured for working bamboo.

The tools essential to building with bamboo are relatively few and simple. In fact, many a bamboo house has been built with no more tools than a machete. But wherever the use of bamboo is to be refined or elab-

orated to any extent, additional tools are required. Some of these may have to perform work peculiar to the processing of bamboo and, for this reason, would not be available at the sources of standard carpentry tools. The Chinese tub- and bucket-maker who uses bamboo as his raw material requires an array of some thirty different tools and gadgets, all of which are employed at one stage or another in the measuring, cutting, fitting, and assembling of the various parts. With the following tools, the standard bamboo elements for building purposes may be processed and assembled:

<u>Tool</u>	<u>Use</u>	<u>Recommended specifications</u>
Machete	Miscellaneous: felling and trimming culms, and cutting them to lengths; removing fragments of diaphragms from bamboo boards; etc.	Preference of the user decides type of blade selected; long, fairly heavy blade recommended.
Hacksaw	Felling culms, removing branches, cutting culms to length.	Large size; ample supply of molybdenum steel blades, with 18 and 24 teeth per inch.
Tripods or trestles . .	Elevating culms and holding them firm for sawing to length, cracking nodes.	May be made locally, following the pattern locally preferred.
Ax	Cracking the nodes of large culms to make boards.	Light-weight ax with a narrow but thick, strongly wedge-shaped bit.
Hatchet or small ax . .	Cracking the nodes of smaller culms for making boards.	Similar to the ax, but smaller in size and fitted with a short handle.
Whetstone	Sharpening edged tools.	Carborundum; coarse-grained on one side, fine on the other.
Spud	Removing diaphragm fragments and excess soft wood at basal end of bamboo boards.	Long handle; broad blade set at an angle to operate parallel with surface of board.

Adz	Removing diaphragm fragments and excess soft wood at basal end of bamboo boards. Spud is more convenient, but the adz is more generally available.	Standard design; best-quality steel.
Gouge	Removing diaphragms to make troughs and drain pipes from split or opened culms.	Curved (front bent); 1-inch and 1½-inch bits.
Chisel	Making holes in culms to accommodate lashings for end ties.	Best steel (molybdenum steel if available); 3/4-inch bit.
Drill	Making holes to accommodate bamboo pins or dowels.	Hand- or power-driven drill; <u>metal drilling bits</u> , best steel, <u>assorted sizes</u> , 1/8-1/2 inch.
Wood rasps	Leveling prominent culm nodes.	Large size, with one flat side, one convex; coarse, medium, and fine teeth.
Splitting jig	Facilitating the splitting of whole culms or sections into several strips at once.	See sketches, fig. 24.
Splitting knives	(a) For splitting small culms. (b) For making bamboo withes.	(a) Short handle; broad blade (fig. 25 A). (b) Long handle; blade beveled on one side only; to be specially made (fig. 25 B).
Rods of reinforcing steel.	Breaking out the diaphragms of unsplit culms.	Suggested minimum: one each of 3/4 inch by 10 feet and 1/2 inch by 10 feet. Other dimensions to meet special needs. Hardwood or bamboo pole may be substituted.
Wire pincers	For handling wire used for lashings.	Conventional type with long, narrow jaws and wire-cutting feature.

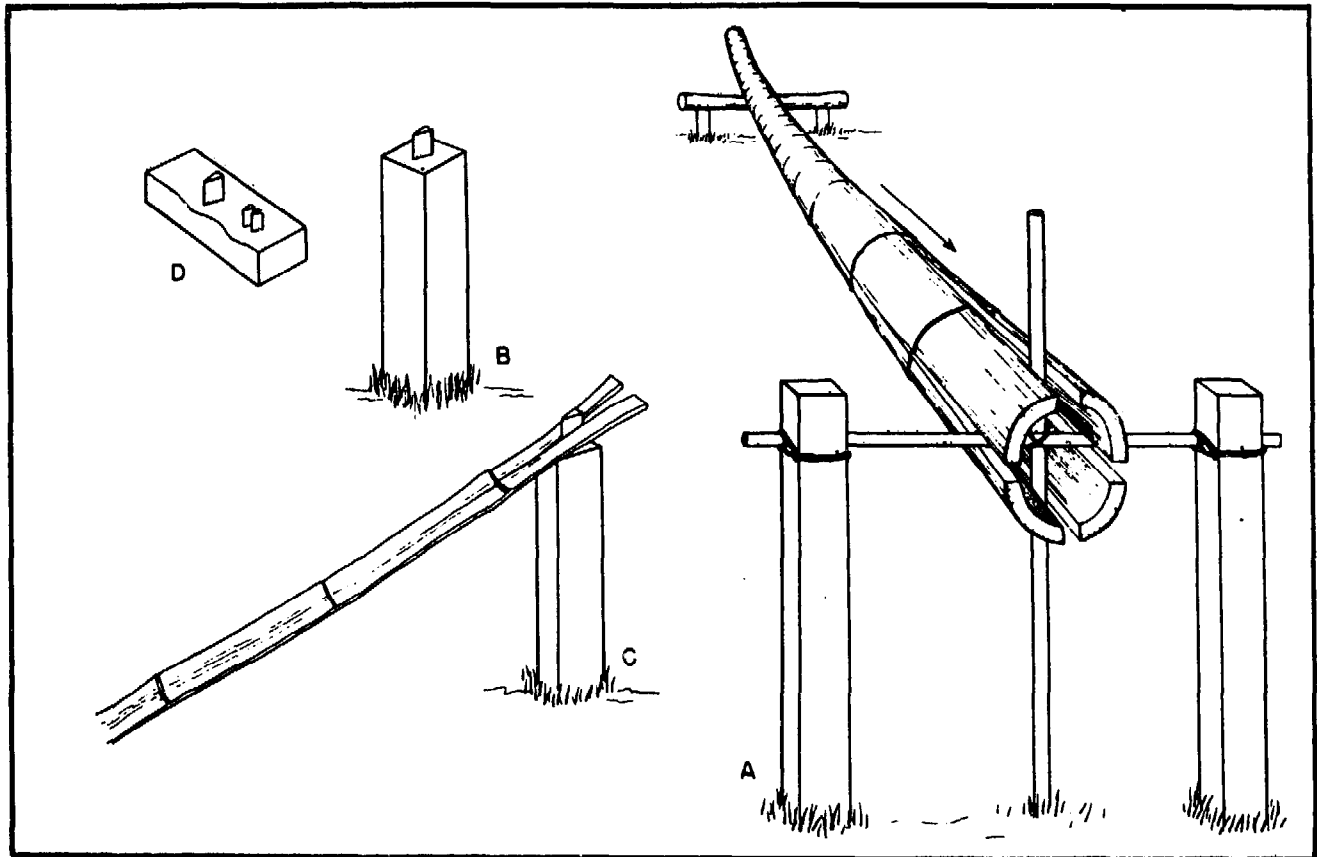


Figure 24.--Devices for splitting heavy culms. A, cross of iron or hardwood bars (about 1 inch thick) supported by posts (about 4 inches thick and 3 feet high) firmly set in the ground; with an ax, two pairs of splits are opened at right angles to each other at the top end of the culm; these are held open with wedges until the culm is placed in position on the cross; the culm is then pushed and pulled, by hand, in the direction indicated by the arrow (adapted from Salcedo). B and C, steel wedge for splitting quartered culms. D, block with single and paired steel wedges for mounting on a heavy bench; adjacent faces of the paired wedges should be slightly closer together at the cutting edge than at the back.

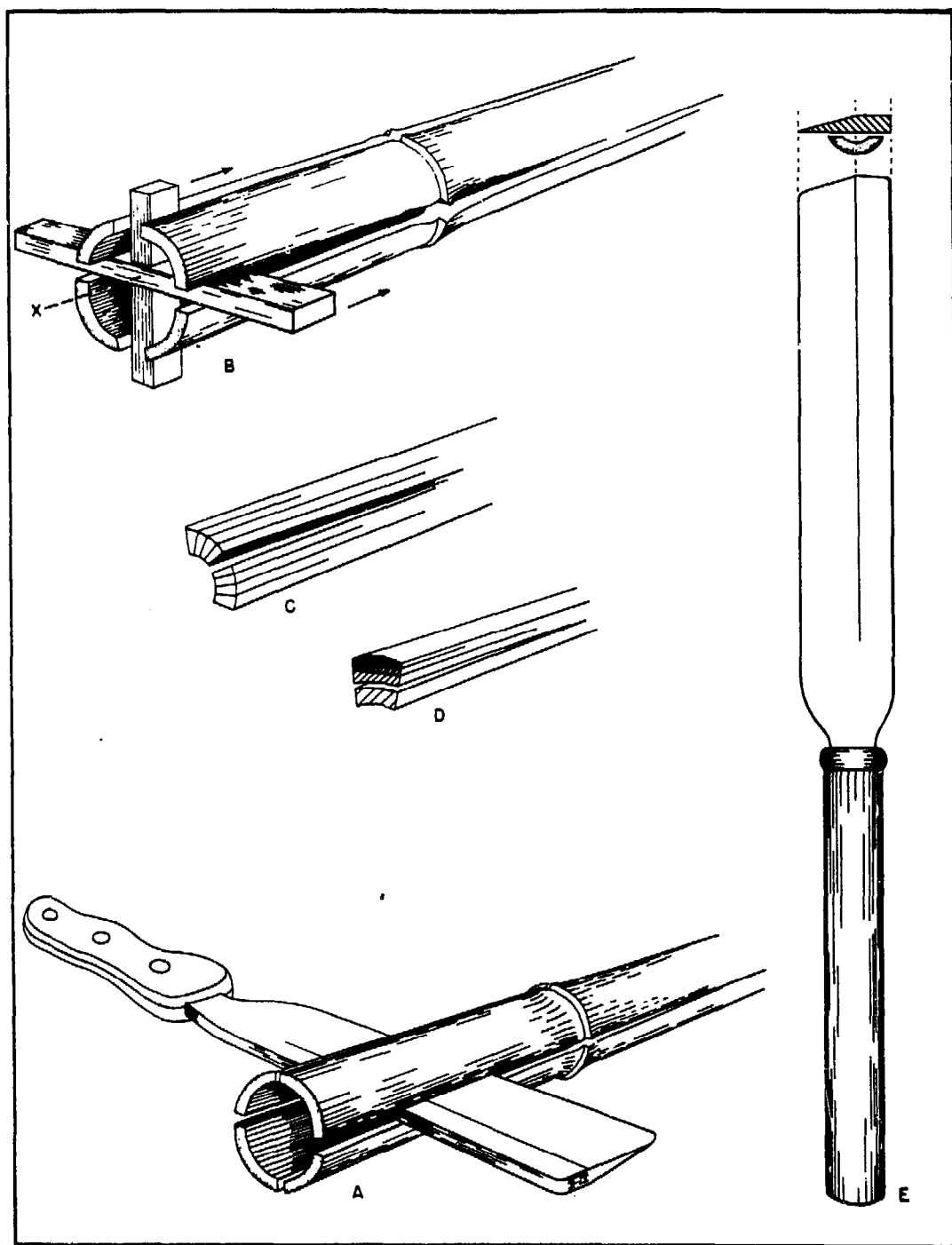


Figure 25.--Splitting of moderate-size culms to make withes for weaving and lashing. Quartering a culm; A, starting four breaches at upper end; B, driving a hardwood cross along the breaches to complete the splitting. C, dividing quarters radially, making center splits first. D, splitting radial divisions tangentially; the hard outer (convex) strip is best, and the soft, pithy inner (concave) strip is usually discarded. E, long-handled knife used for C and D; some workers hold a strip of bamboo on the blade to add to its effective thickness when they wish to speed up the work.

Chapter 3.: Bridges

Bridges on piles or supports

- 3.1. - A Bamboo footbridge,
from R.E.T.M. no. 17 page 57 p. 79
- 3.2. - An experimental bamboo bridge
from The Military Engineer (1937) p. 288-289 p. 80
- 3.3. - The Pylon Bridge
from Scout Pioneering (1974) p. 82
- 3.4. - Footbridges of bamboo
by F. Trojani (1930) p. 84

Floating bridges

- 3.5. - Mat Bridges and Expedients
India (1942) p. 90
- 3.6. Floating Bridge for Vehicles
R.E.T.M. no. 17 section 21 p. 48-49 p. 94

Hanging bridges

- 3.7. - Improvising with jungle vines
R.E.T.M. no. 17 section 22 pages 49-50-51-57 p. 96

All texts from R.E.T.M. (Royal Engineers Training Memorandum,
1945) by Courtesy Ministry of Defense, London, U.K.

3.1.

A BAMBOO FOOTBRIDGE;

1. A form of foot bridge commonly used in Manipur is shown at fig.27 It is a good type for rivers with muddy or sandy bottoms, where the height of the bridge above the bed need not be more than 5 metres (15').
2. The bridge is made entirely of bamboo, and bindings are of bamboo strips. This binding, which is used very widely in Assam, is much quicker than making twisted bamboo lashings. The method of using them is to make a round turn with a strip round the two bamboos to be bound together. Then pull as tight as possible, twist the two ends together and tuck them under the round turn. With a little practice this results in a very quick and secure binding.
3. The time of construction when the bamboo is near the site is about four hours for a 20 metres (50') stream with a party of 20 men.

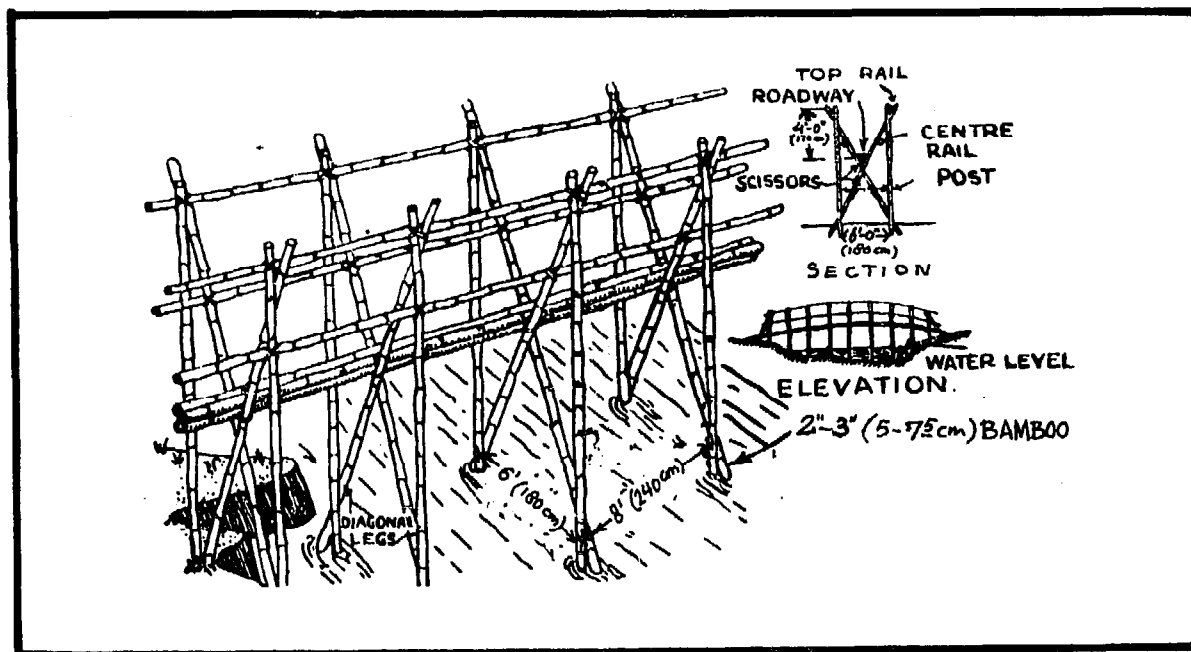


Figure 27 A bamboo footbridge.

An Experimental Bamboo Truss

GEORGE KUMPE

First Lieutenant, Corps of Engineers

TO even the most casual visitor in the Philippine Islands, the universal use of bamboo for many varied purposes is an outstanding characteristic of the country. To a visiting engineer especially, bamboo has a particular fascination as an engineering material, for its properties of great length, durability, workability, straight grain, light weight, and high tensile strength permit its use in practically all types of construction. Specifically, the use of bamboo in bridges is prevalent throughout the Islands, but only in trestle bridges. As far as could be learned, there is no record of the construction of a bamboo truss bridge. To determine the possibility of erection and the feasibility of such a bridge, it was decided to test a full-size structure.

The task of erecting a bamboo truss bridge was assigned to Company C, 14th Engineers, Philippine Scouts, as a portion of its training. There were available four mornings of work for the construction and erection of the bridge. Cutting details, requiring 112 man-hours of work, previously obtained the necessary bamboo. Certain restrictions regarding cutting bamboo on the reservation resulted in improved quality of material and balanced the loss of time resulting from long hauls. The site of the bridge, a gully on

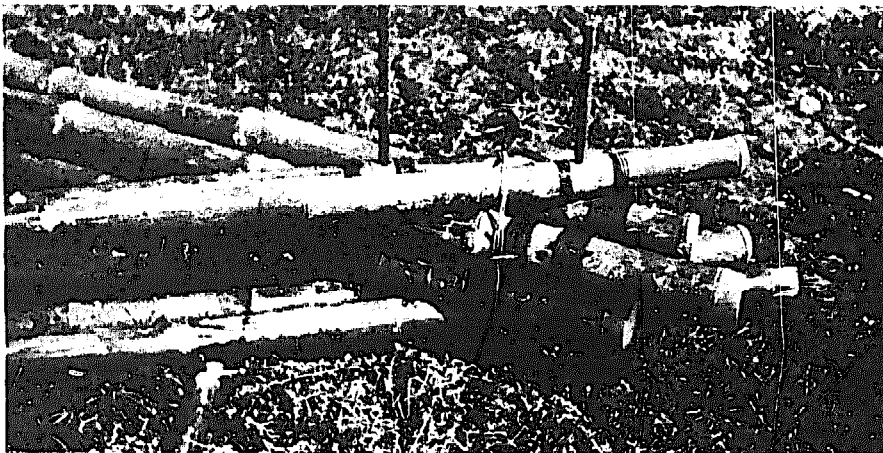
viously been proven satisfactory, it was decided to use bamboo road bearers with a floor system taken from the canvas-covered ponton equipage. The actual design of members was purely arbitrary. A rough analysis of the bridge under an assumed load of a pick-up truck (3,275 pounds) was used for determining the relative stresses. Since little information is available on the physical properties of bamboo, the design was empirical, based upon experience and opinion, and consisted only in assigning the number of pieces of bamboo to each member. The actual arrangement of pieces in the members was determined by the panel point construction, and was decided upon when the trusses were assembled.

The construction of the trusses was a problem in joint design. It had been decided to use four pieces of bamboo in the lower chord and end posts, three pieces in the upper chord, and two pieces in the suspenders and diagonals. This resulted in a maximum of eleven pieces of bamboo, at the upper chord joints, so these points became the determining factor in the erection, and the other joints were assembled to match. In the actual type of joint there was small choice. Carefully framed butt joints, and fish plate joints were both considered, but variations in the size of the members, and their eccentricity, together with a lack of suitable material for fish plates, prevented such construction; so pin connected joints were used. At first the native type of construction, with bamboo pins, was tried, but the pins were too weak for the load. Pins of $\frac{1}{2}$ -inch square reinforcing rods, 18 inches long, were next tried, and proved satisfactory.

The joints were originally designed as simple single-pin joints, but were impractical, since eleven pieces of bamboo would have made a joint over 4 feet wide. As finally designed, the upper chord was arranged with two pieces of bamboo above the remaining pair. The

bamboos of the other members entering the joint were arranged symmetrically about the upper chord members. Two pins were used, one for each pair of upper chord members, the pins also going through as many other pieces as was possible. The center bamboo of the end post was not secured to either pin, but was lashed to the outer members and also pinned to them by bamboo pins.

In assembling the joints, each pin hole was first drilled. The bamboo on each side of the hole was tightly wrapped with baling wire and marline to prevent splitting. The entire joint, after assembly, was then tightened and secured by the use of heavy wire and rack sticks. Splices on the lower chord were made in each end panel. The members overlapped about 5 feet, and were placed so that butts and tips al-



Lower Chord and End Posts

the reservation, was selected without regard to the usefulness of the structure, the actual abutments being far from ideal for any bridge construction. Since the structure was intended for purely experimental purposes, no attention was paid to approaches, retaining walls, or other problems attending traffic.

The design of the bridge was like Topsy, it just grew. The site chosen for the bridge required a 50-foot span. Since the construction was intended for training in truss bridge erection and terminology, a king-post truss was eliminated as being too simple for instruction purposes. These factors finally determined the structure as a 50-foot queen-post truss. Since the men were highly familiar with trestle bridges and ponton equipment, no special attention was given the flooring system. Bamboo having pre-

ternated. The actual connection was accomplished by tight lashings of wire and marline, with bamboo pins.

Erection was very simple. The individual trusses were assembled on level ground near the bridge site. The flexibility of the bamboo made joint assembly an easy process. After the trusses were completed they were carried by hand to the proper location. Two



Carrying the Truss to the Site

squads were used for moving each truss due more to their spring than their weight. Each truss weighed approximately 900 pounds.

Actual erection consisted of sliding a truss over the bridge site horizontally while bracing at panel points with bamboo posts extending to the ground. When the lower chord reached its proper position the truss was raised to its vertical position by means of lines and poles, a simple operation due to the light weight. No special seating was provided for the truss on the embankments, the width of the lower chords providing sufficient bearing. The two trusses were braced laterally by single bamboo poles between upper panel points.

The flooring system was that of the canvas-covered ponton equipage. The two abutment sills were placed over the ends of the truss lower chords and were further supported by bearing on earth. The two intermediate road bearers were originally made up of four pieces of bamboo first lashed together and then lashed on top of the lower chords next to the suspenders. These bearers were later replaced by narrow gauge railroad rails in the same position. Six balks were placed in each bay, and ordinary chess used for flooring. Side rails were lashed as in ponton bridge construction.

Tests of the bridge were made by loading the structure with a condemned escort wagon. The wagon was pulled back and forth across the bridge with various loadings and at various speeds. The bridge was not loaded to failure. The maximum load applied was the escort wagon, weighing about 1,500 pounds, carrying approximately 1 ton of rock.

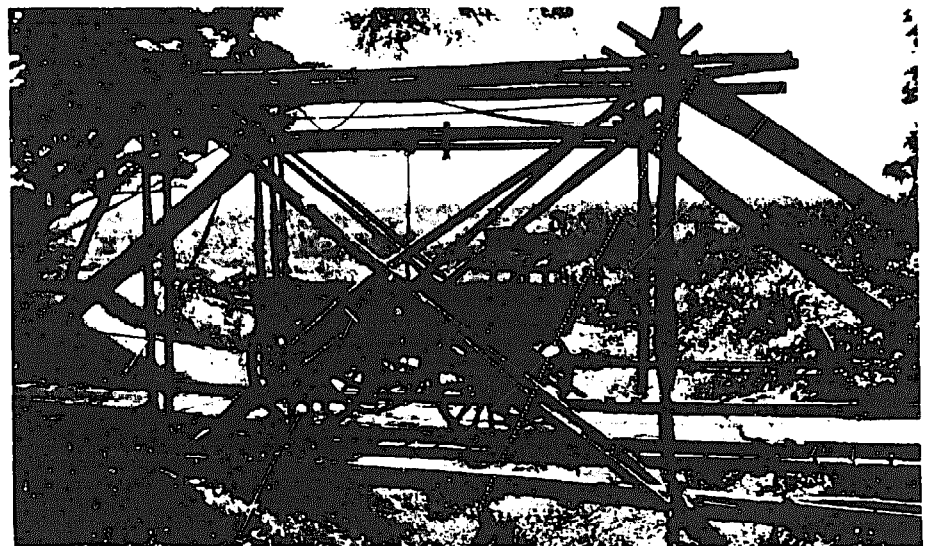
The behavior of the bridge was most interesting to watch. As expected, the entire structure was very elastic. As the load was applied all the members, being eccentric themselves, and non-axially loaded

either in individual members or panel points, all bowed in the direction of their distortion. The initial loading resulted in crushing the bamboo road bearers at their bearing points on the trusses; so railroad rails were substituted. In all the tests the flooring showed the greatest deflections. As mentioned, the usual side rail lashings were used, but even so, the side rails separated as much as 5 inches from the flooring during maximum loading. From observation it seemed probable that if the bridge were loaded to destruction the balks would fail first, so to prevent useless breakage no excessive loads were tried.

Examinations of the various details of assembly were made during and after loading. The method of placing road bearers on the truss instead of suspending them resulted in crushing the upper two bamboos in the lower chord, but not sufficiently to cause serious results.

In several cases the steel pins had moved slightly and torn the bamboo members, but in no case, was the damage enough to render a member inactive. Even at the panel points, where some members were not directly pinned to the pin connections, there seemed to be a proper distribution of the loads. The pins themselves proved adequate. At the splices there was no indication of slipping, which the placing of pieces with alternate tips and butts rendered unlikely.

This experiment seems to prove the feasibility of bamboo truss bridge construction. With certain changes of design, chiefly the addition of balks to stiffen the flooring and the fastening of road bearers to the trusses by slings, it is felt that bridges can be constructed for any reasonable load. A bridge built entirely of bamboo, both trusses and floor system, also



The Bridge under a 3,500-pound Load

seems possible, but the combination of bamboo trusses, ponton flooring, and some metal road bearer, seems at present to be the most efficient use of available equipment and material.

This use of bamboo will probably not often be necessary, but it serves to illustrate one of the many ways in which it may be employed.

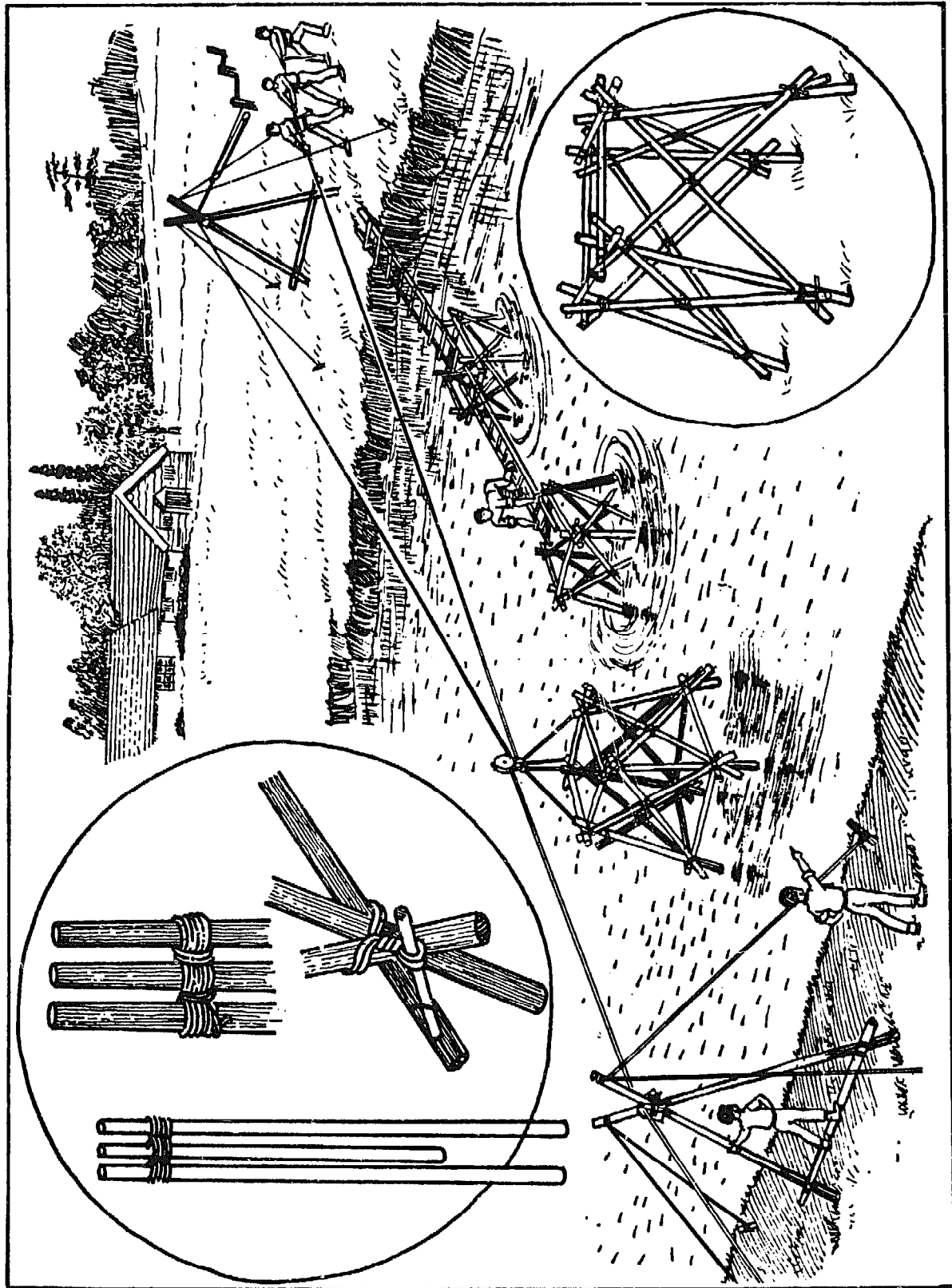


Figure 30 Pylon bridge, based on ten-minute-tower.

The Pylon Bridge

from: Scout Pioneering by John Sweet.

London 1974.

In practical terms, the idea behind the building of this bridge was to break new ground by using the so-called 'Ten-Minute Tower' to provide pylons for an exceptionally long footbridge across the widest part of the Bomb Hole. In preparation for this activity (for time was strictly limited) a very strong fore-and-aft runway had been set up across the Bomb Hole and the footway had been prepared in sections so that they could be dropped in place the moment each pair of pylons were in position. Luckily we had access to a pile of builders' planks which made the job easy.

The project, I may say, was a howling success, despite—or perhaps because of—the need for some frantic on-the-spot improvisation. One thing we had not realised, for instance, was that the Ten-Minute Tower, though reasonably stable when standing on its own four legs, is apt to fold up at the base when lifted clear of the ground. This difficulty was quickly overcome by lashing a few extra struts to keep the legs apart until the pylons were safely embedded in the mud. The climax came when the entire course lined up across the bridge to have their photographs taken. All would have been well had not one of the Gilwell spars turned out to be rotten at the heart (something that would have been discovered in time if the spars had all been submitted to the ringing test, as instructed.) But it's an ill wind . . . and to this day I treasure the spectacle of a cataract of boys diving headlong into the muddy waters of the Bomb Hole and laughing their heads off in the process. I doubt if Gilwell has ever seen a finer sight.

3.4.

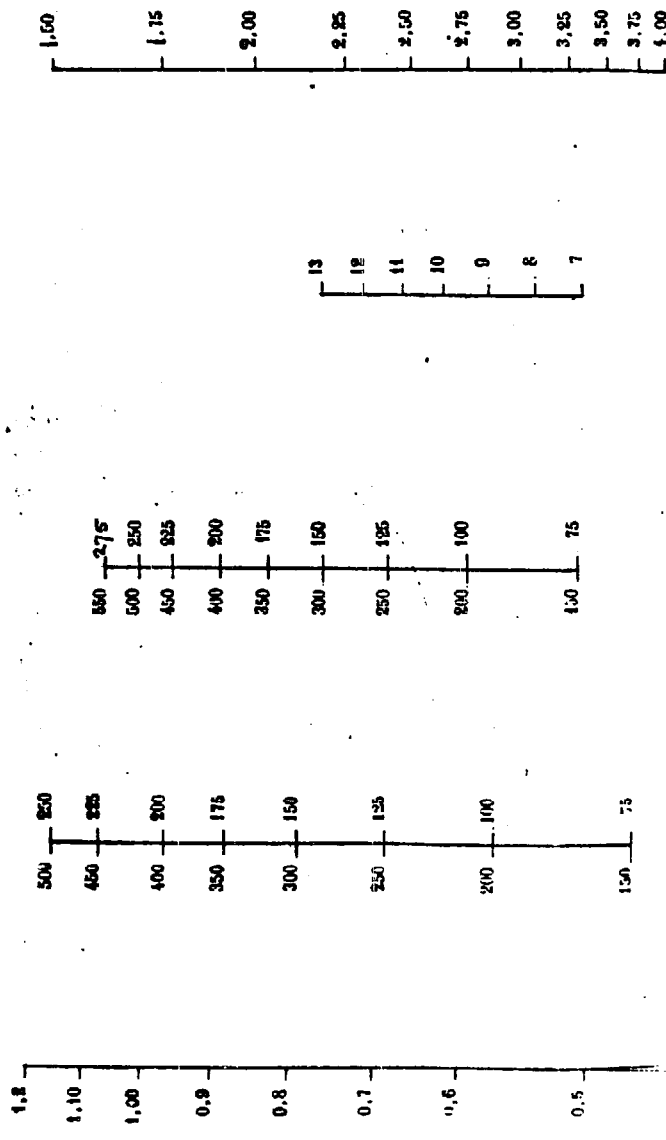
THICKNESS
in cm.

A

BREAKING POINT LOAD in kg.
(left); safe load in kg (right)

DIAMETER in cm.

SPANS in mtrs.



Note: safety-coefficient = 2

Figure 32: Nomogram to obtain the breaking point load of a given bamboo.

At the request of M. Inspector General of Agriculture, Stockfarming, and Forests, the Company du Genie set up at the Fair Exhibition of Hanoi in 1928 a series of partially built bamboo footbridges. Many visitors asked afterwards for further information about this subject, we have condensed this information in the following study.

Material used - The only material used are bamboos - standard usage groups bamboos in two main categories: male bamboos, or bamboos with thick walls and female bamboos, those with thin walls.

The first serve to make piles and all the sections of the frame. Those of the second category are used for the making of cai-phen and of cai-lat (lashings-bindings). It is necessary to use fairly young bamboos as after the age of two years bamboo having reached its maximum height, the thickness of the crown diminishes year by year by about 1 m/m till seven years; at this time it is only 5 - 6 mm and the bamboos whose average diameter may reach 20 cm, no longer has the required qualities for making piles.

Compression Resistance of Male Bamboos - Tests carried out by Capitan Nicholas of the Company due Genie of Hanoi led him to the following conclusions:

Given a male bamboo pile whose average external diameter is of n -centimetres its absolute safety-load is $60 \times n$ -kilograms provided that its free height is at most equal to n metres and that the thickness of the crown at least equal 10 m/m.

Resistance to flexion - Given a male bamboo girder whose external average diameter is a number n of centimetres the load it can take without breaking is in all cases at least equal to $\frac{100n}{3}$ kilograms provided that the span of this bamboo is at the most equal to 3 metres.

On the other hand Lieutenant Vincent of the Company du Genie of Hanoi has carried out a series of tests of the flexion-breakage-resistance where he varied the length, the diameter, the thickness and the span of bamboos. The results were rather variable because of:

1. The condition of the bamboos: age, degree of humidity or of dryness, antecedent use;
2. The props (stays-supports) - the prop should, as far as possible, be near a knot;
3. The flexion-resistance variation of the samples taken from the same bamboo between knots of the same distance apart.

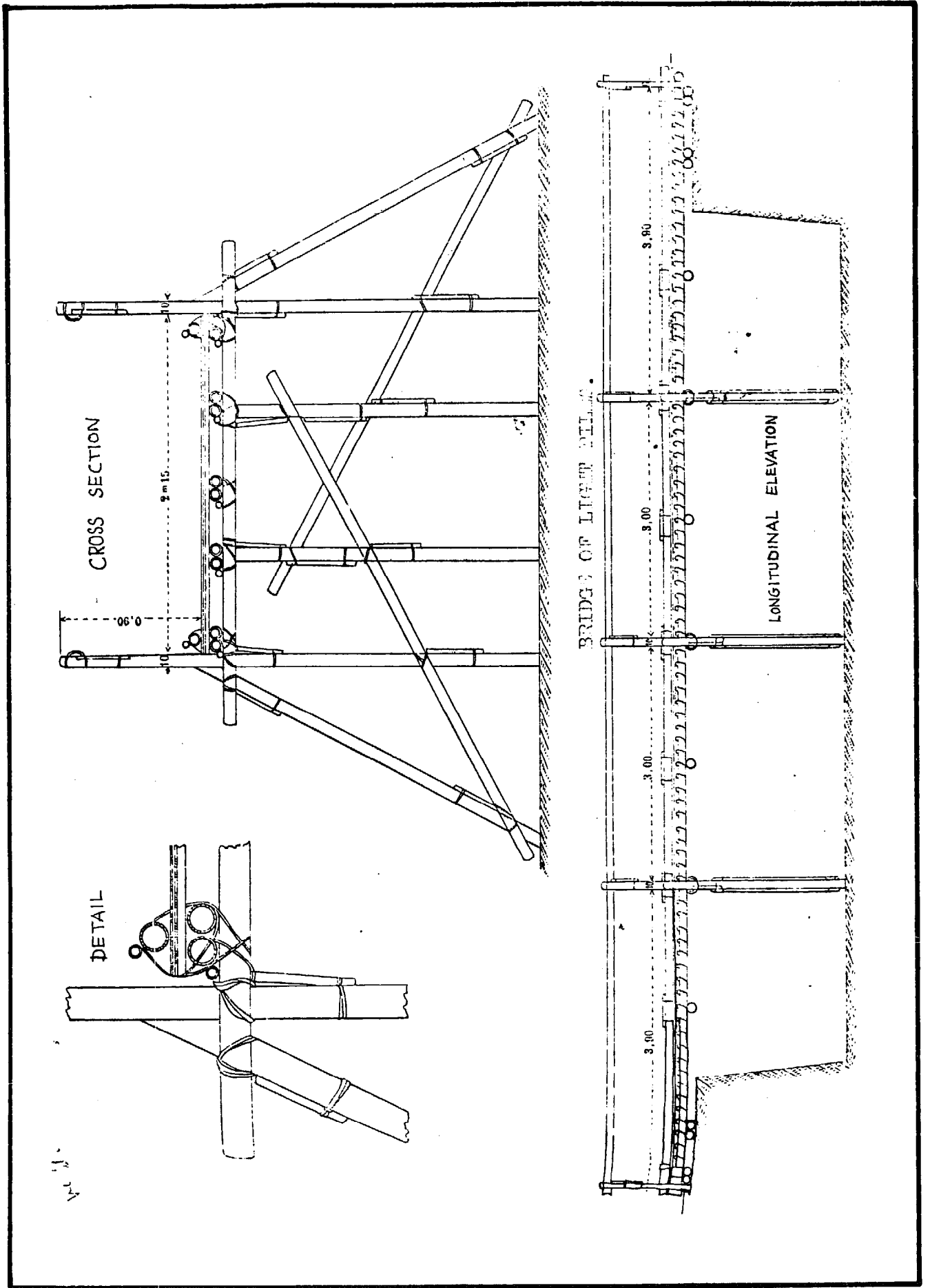


Figure 33 Bridge of light piles.

Nevertheless the averages obtained from bamboos cut six months previously are quite well represented by the nomogram attached here.

Adopting a safety-coefficient of 2 one can be sure that no bamboo will break provided it is neither too old or split. To obtain by means of this nomogram, which shows scales of points, the load breaking-point of a given bamboo, all one needs to do is to join with a ruler the points corresponding to its thickness (scale of thicknesses) and to the diameter (scale of diameters). This determines a given point of scale A; join this point to the point corresponding to the span (scale of spans); this determines the breaking-point-load, from which the permissible load on the scale of loads is deduced.

The sinking (or driving-in) of the piles - in muddy ground - firm mud - the sinking of a bay (span) of bamboo piles gives rise to no danger; if the stake is 1.70mtr. In good ground this stake may be reduced to 1 metre.

Here, as an example, is the description of the bridge of light piles and of the bamboo footbridges built under the direction of Captain Piacenins by the Company du Genie at the Fair Exhibition of 1928.

I-Bridge of Light Piles

Abutment-pier - Each pier is made up of 2 moorings placed about 80 cm apart. Each mooring is made of 2 bamboo fixed longitudinally together and fixed to the ground by stakes planted in front and behind.

Sheet piling - Each section is placed 3 metres apart. Each section is made up of 4 vertical piles, of 2 braces (struts), of a cap (hood) and of 2 diagonal braces.

The vertical piles and the braces are made of bamboos 8 to 12 cm diameter at the large end. The small ends are cut back to the required length and they are cut slantwise. The piles are driven in with a sledge-hammer.

The Cap (hood) is made of 2 bamboos tied together and fixed horizontally to the piles by lashings as indicated on the diagram. Two diagonal braces placed on both sides of the sheet piling, are also lashed to the piles.

The spacing of the piles is, in general, 75 cm axis to axis. In the particular case of the diagram the bamboos at the far ends making the vertical piles are kept longer so that their prolongation can be used to make a guard-rail.

On the other hand, the spacing between the middle piles is greater than the spacing of these last ones with the piles of the far-ends.

Bays and roadway - Each girder is made of two bamboos lashed together of average diameter 10 cm. Each bay is formed of 5 girders equi-distant and lashed to the caps of the sheet-piles.

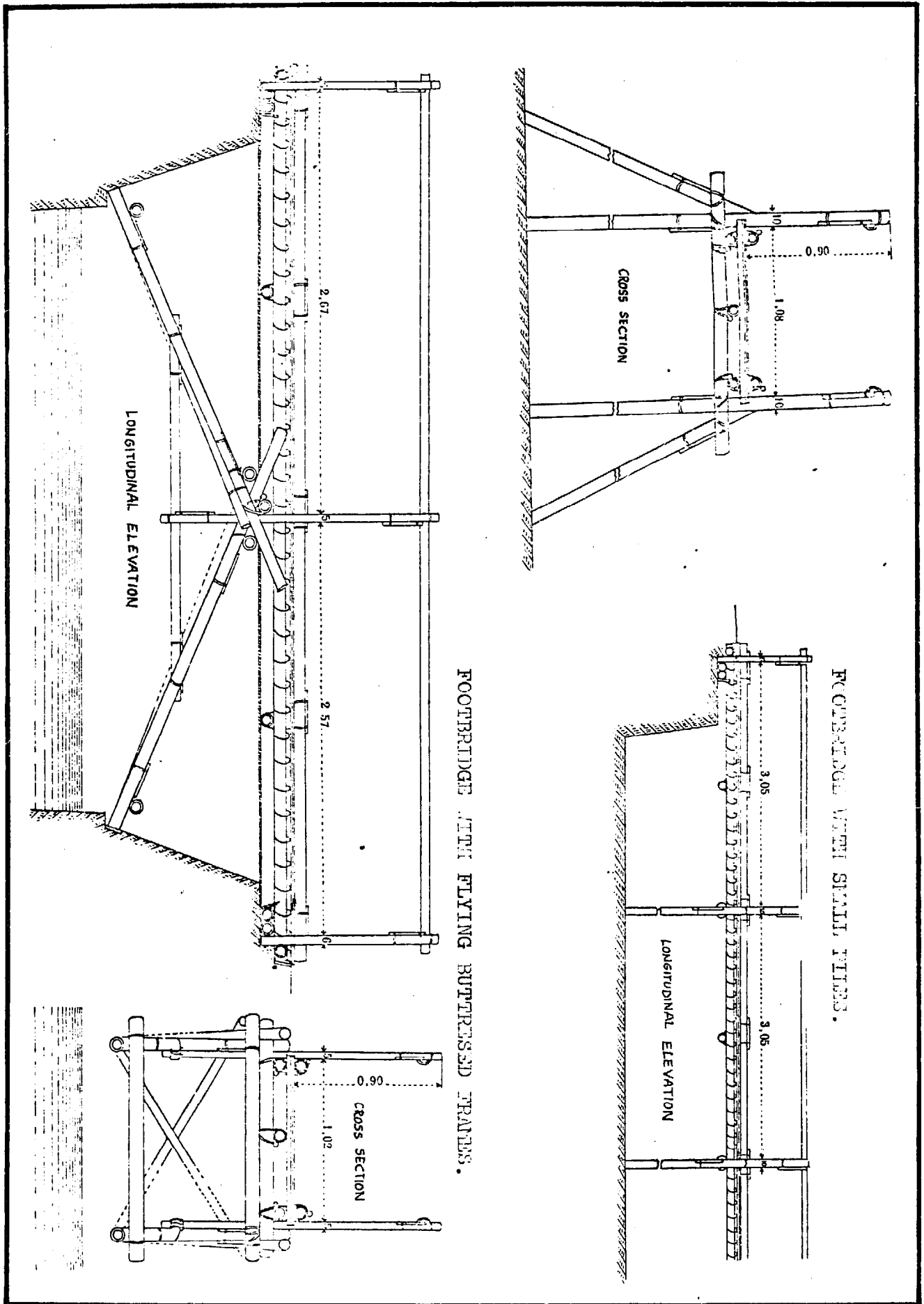


Figure 34 Two bridges.

The flooring (surface roadway) is made of sheets of male bamboo fixed to the girders by cai-lat. These bamboos are simply separated by the thickness of the binding (lashing) material. Then they covered over with cai-phen.

In the middle of each bay a bamboo lashed crosswise to the girders distributed the stress and acts as a reinforcement device.

The ribband is made of bamboos longitudinally placed on the roadway and superimposed over the far-end girders to which they are secured by torsion lashing.

Maximum loads - This bridge can carry 500 Kg per metre length. It allows for the crossing of herds, animal-drawn and open wagons for 4 people plus loads.

Footbridges of small piles

Abutment-pier - It is constructed of a single mooring analogous to those of the light-pile bridge.

Sheet-piling (side) - The sections are spaced 3 metres apart. Each section is made of 2 vertical piles, 2 struts (braces) and a cap (hood) arranged as on the diagram. The piles and the braces are made of bamboos of average diameter 10 cm at the large end.

Bays and roadway - The girders are of bamboos of average diameter 10 cm cut back to the required length. Each bay is made of 3 girders equidistant lashed to the caps of the sheet pilings. The flooring and the ribband are analagous to those of the light-pile bridge.

Maximum loads - This bridge can carry 200 Kg per metre-length. It allows of the passage of people, merchandise carried on the back or on small hand-carts.

Footbridges with flying-buttresses frames

Abutment-pier - The abutment is analagous to that of the precedent bridge.

Frames - The frames are made by means of bamboos of diameter 10 cm to 12 cm at the large-end, placed and lashed as on the diagram. The buttressing is consolidated by means of diagonal braces.

Roadway - A bamboo acting as cap is lashed to the crossing of the frames. The girders may be made either of bamboos having the total length of the bridge, or of bamboos cut back to the length which separates the cap from the moorings.

Three rows of equidistant girders are positioned. The lashings, the ribband and reinforcement device are analagous to those used for the proceeding bridges.

Maximum loads - This bridge can be used for the same purposes as the footbridge of small piles.



Photo 1. Bamboo inserted into the matbridge.

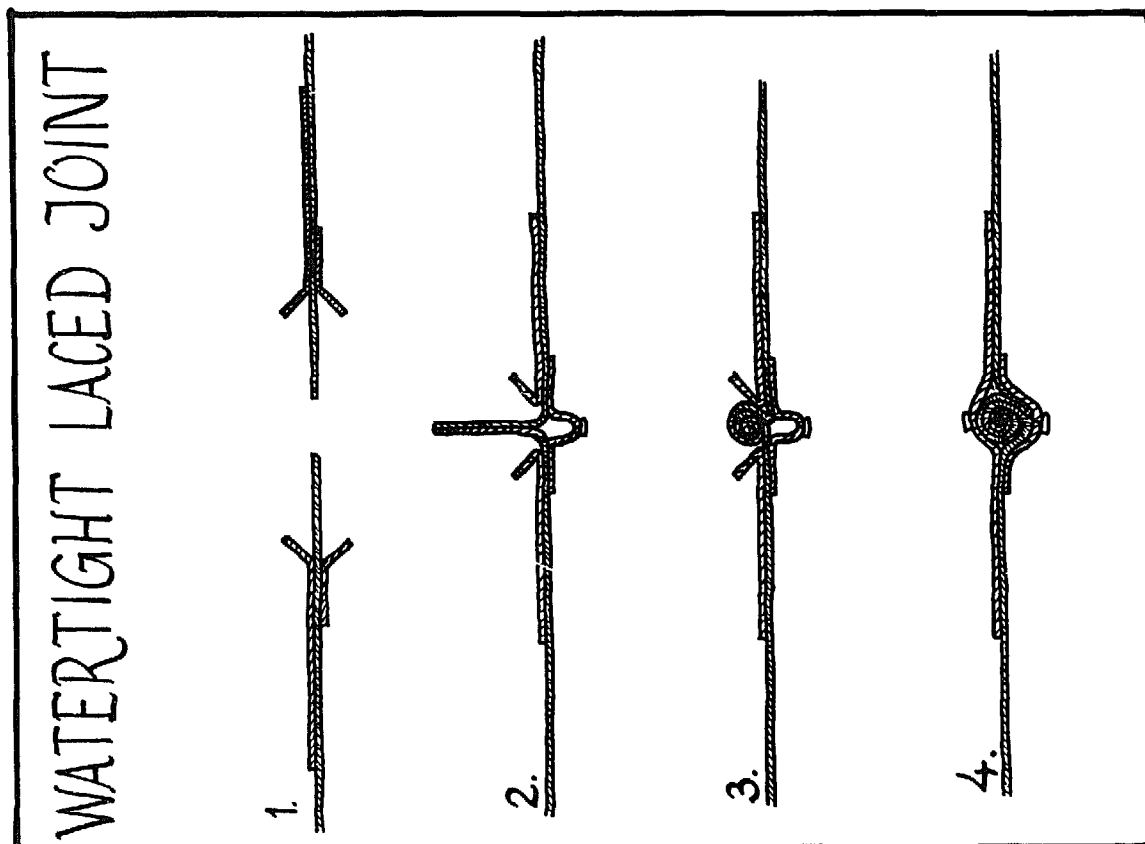


Figure 31. Watertight laced joint in canvas.

3.5.

MAT BRIDGES AND EXPEDIENTS

Source : British Army : India 1942.

1. The main object of the expedients and floating bridges described below is to replace equipment which has to be imported and may be difficult to obtain in India.

All the materials used, except in one case, are easily obtainable in India, and the bridges and expedients can be made up by an engineer field unit or in a bazaar workshop.

2. The use of tarpaulins to form the mat

Waterproof canvas tarpaulins are used to form a watertight skin on which some form of superstructure is laid which can carry men or vehicles.

The skin requires to be stiffened to keep it spread flat on the water. This is usually done by means of bamboos but in the Middle East split palm braches are quite suitable.

Figure shows bamboos being inserted into the mat of Indian Mat Bridge. In order to prevent the water lapping over the edges of the skin, they are rolled up round straw or some other light filling (see photo 1) and laced down to a flap sewn at a suitable distance from the edge of the tarpaulin. Both the edge and the flap have eyeletholes fixed in them.

The third requirement of the tarpaulins is that it must be possible to join them together by a water-tight joint which can be easily made so that the skin for a long bridge or a very large raft can be transported in sections. This joint is made up as follows :

Tarpaulins have flaps stitched on both sides parallel to the edges and about 2' distant from them. The flaps are about 3" wide with eyelet holes at intervals of one foot. When such flaps are provided the tarpaulins can be joined end to end or side to side to form a narrow or wide mat, whichever may be required. Say two tarpaulins are required to be joined end to end. First of all the bottom flaps are laced together (see fig.31), then the spare ends of both tarpaulins are rolled down tightly together and finally the two top flaps laced over to pinch the roll into a small a space as possible and so to make it water-tight.

Provided the roll is tightly enough pinched the joint is quite water-tight.

After the waterproof skin has been prepared, a superstructure to take the required load must be placed on it.

3. Mat bridges

A waterproof mat long enough to stretch across the gap to be bridged is made up from a number of tarpaulins joined together. The end and edges of this skin are turned up over some light filling, such as straw, or round cushions made of waterproof canvas and stuffed with straw (photo 1). Bamboos from 2,5-5 cm (1-2 inch) thick are used for cross-wise stiffening of this mat.



Photo 2. First indian matbridge.



Photo 5. Footbridge.

Some form of roadway suitable for the required loads is then laid on the mat.

Photo 2 shows chesses placed on three straps fitted with stirrups, which project upwards between chesses and through which run rolled steel joist ribands. The rolled steel joists are wedged under the stirrups or clamped down by some other means.

It is important, that the rolled steel joist sections be joined rigidly together throughout the length of the bridge so as to distribute the superimposed load over as great an area of water as possible. In light loads straps 5 x 1 cm (2" x ½") and 10 x 4 cm (4" x 1½") rolled steel joists ribands were found to be adequate.

4. The Indian Mat Bridge

Figure shows the first Indian Mat Bridge classified bridge for max. loads of 5 metric tonnes, the principle being used in a motor transport bridge. The sizes of the various parts used are as follows :

(a) Width of mat	660 cm (22')
(b) Diameter of cushions	30 cm (1')
(c) Thickness of Bamboos	2,5-5 cm (1" -2")
(d) Section of iron under strap	5 x 1,25 cm (2" x ½")
(e) Size of deodar chesses	300 x 22,5x7 cm (10' x 9" x 2½")
(f) Section of ribands	10 x 4,5 cm (4" x 1½").

This type can be used either as a bridge or a raft for light motor transport and can be built either by boombing out from the bank or by swinging out complete from along the bank.

Although so far only a bridge for max. loads of 5 metric tonnes has been produced, there is no reason why by increasing the size of parts used bridges to take much greater loads should not be made.

5. Foot bridges

Two types of foot bridges have been made, each has waterproof cushions under the turned up sides. The stiffening of one of the bridges consists of masonite sheets placed on the mat and covered by a canvas flap to prevent excessive wear of the sheets. The second has a double layer of reed matting with a layer of coir matting above it to form the pathway. Photo 3 shows this type of bridge. It is six feet wide and can take two way pedestrian traffic. The best way of launching these bridges is to take a rope across the gap to be bridged and to pull the bridge across as it is made up. When across, the bridge takes a curve down stream and does not need to be kept straight across the current.

3.6.

FLOATING BRIDGE FOR VEHICLES.

From: R.E.T.M., no. 17, section 21
pag. 48-49

1. A jeep mat bridge. - A bridge working on the same principle as the Indian mat bridge has been designed and tested for carriage of loads up to 3 mtr. tonnes. The origin of the design was the desire to produce a bridge which could carry and be carried on jeeps. In order to obtain this the stores required have been reduced to mats, bolsters and cordage. All decking must be improvised locally.

The device as originally tested employed mats with grass-filled bolster bags roped into the edges, forming a longitudinal gunwale on both sides of the bridge. No transverse stiffening other than the decking itself was used. Decking tested was of two types: -

a) bamboo hurdles, and

b) chesses with lashed bamboo ribands and roadbearers.

If the superstructure can be obtained from local bamboo or timber, the weight of stores to be carried is 22 kgs per meter run (15 pounds per foot run) of bridge. If chess decking is required, this weight will be increased to 105 kgs per meter run (70 pounds per foot run).

The initial test showed that a bridge of this type is amply safe for maximum loads of 2 metr. tonnes and will take loaded jeeps or unloaded 750 kgs. trucks (15 cwt.). The main difficulty encountered was that grass filled bolsters become water logged in time, and it is thought they would have to be renewed every 12 hours for a bridge in continuous use.

To increase the capacity of the bridge to max. loads of 3 m. tonnes and to allow occasional loads to 4.m. tonnes to pass singly, trials were carried out using kapok bolsters; weight of stores per meter run of bridge, when mats, cordage and kapok bolsters are carried is in the region of 30 kgs. The trials were completed with 270 cm (9-foot) chesses on bamboo roadbearers, secured by snake lashing between alternate chesses to bamboo ribands; and also with a superstructure of bamboo hurdles lashed longitudinally and transversely, the longitudinal bamboo hurdles overlap approximately 3 feet, and the third hurdle is placed centrally to prevent articulation under load. The results of both trials were satisfactory and show the bridge to be stable and capable of supporting max. loads of 4 m. tonnes with safety.

The bridge in either form is very easily constructed, and where the bamboo hurdles are ready made, speed of erection is estimated to be 150 meter of bridge per hour with a party of 20 men.

2. A floating barrel jeep bridge. - A floating bridge to carry jeeps with stores across a 60 mtrs. (200-foot) river has been constructed from pontoons and barrelrafts connected together. The barrelraft portion of the bridge was constructed as shown below. This proved to be durable since it was in use for 21 days for continuous jeep traffic, although it was designed to last only a few days.
- The barrel type portion of the bridge was not of orthodox construction with superstructure on top of the barrels. It was found better to construct the frame of jungle timber, lashed together with wire, and then lash the barrels on top of the superstructure, leaving space for a roadway between.
- The advantage of this method is that the roadway is much nearer to the water level, which simplifies loading problems.

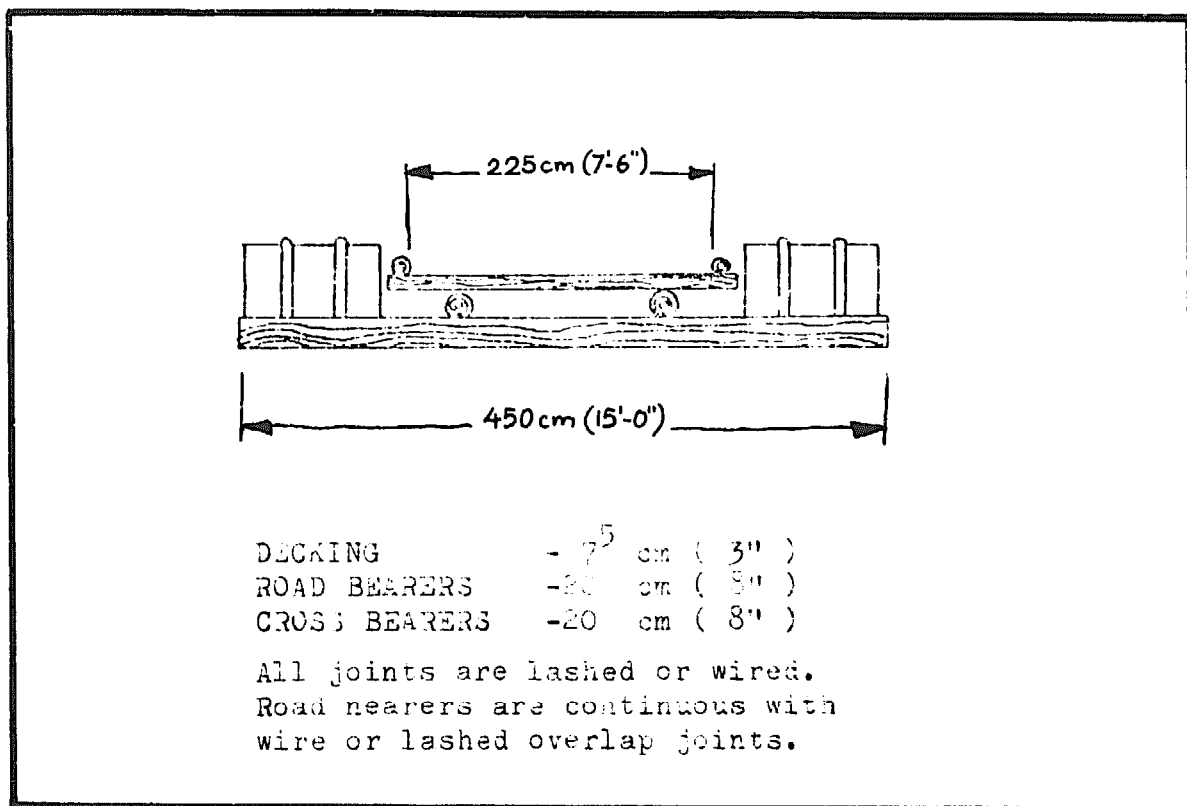
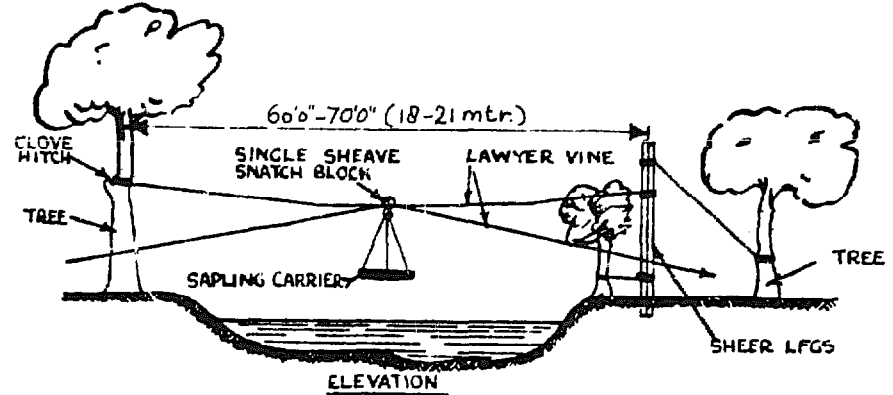
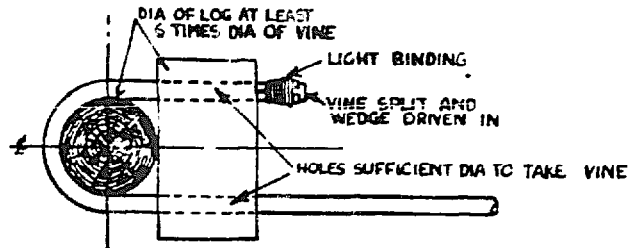


Fig. 22. Cross section vehicle pontoon bridge.

VINE AERIAL CABLEWAY

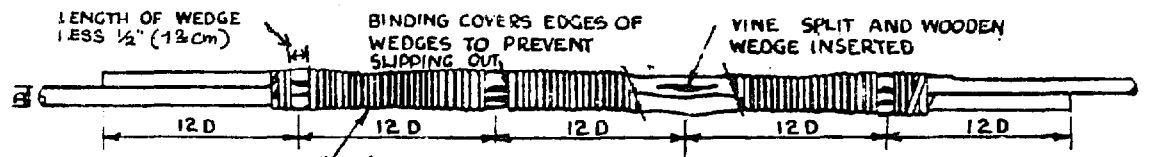


METHODS OF JOINING LAWYER VINE

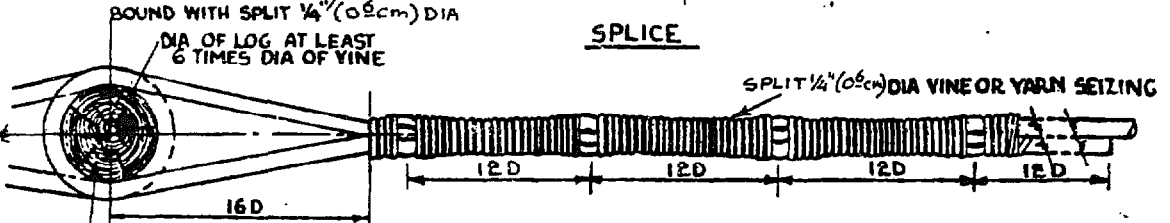


ANCHORAGE
SPlice HAS BEEN TESTED AND FOUND AT LEAST AS STRONG AS THE VINE

D - DIA OF VINE

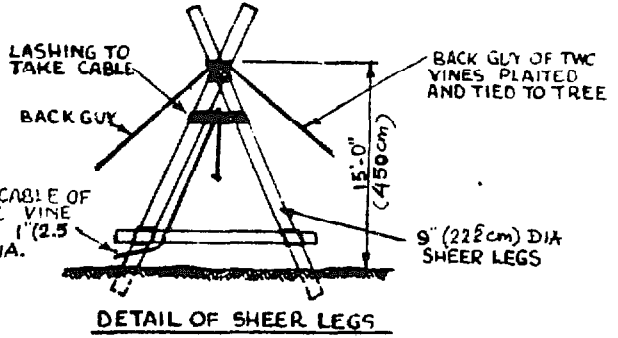


SPLICE



ANCHORAGE OR SPLICE

LOG MAY BE USED AS PIN FOR SPLICING AS SHOWN FOR LONG SPANS AND SPEED IN MAT CONSTRUCTION.



MAIN CABLE OF SINGLE VINE APPROX 1" (2.5 cm.) DIA.

Figure 23. Vine aerial cableway.

IMPROVISING WITH JUNGLE VINES.

From: REIM., no. 17, section 22.
pag. 48-49.

GENERAL. - An aerial ropeway and a suspension bridge have been constructed with lawyer vines for cables as shown at pages 96 and 98.

Scrub bamboo and thin vines were used for binding and marrying large vines; and saplings for cross girders, stringers, decking and slings.

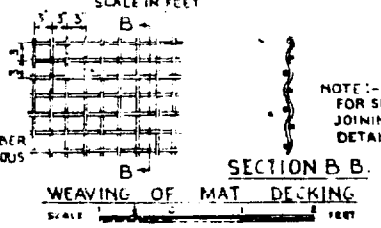
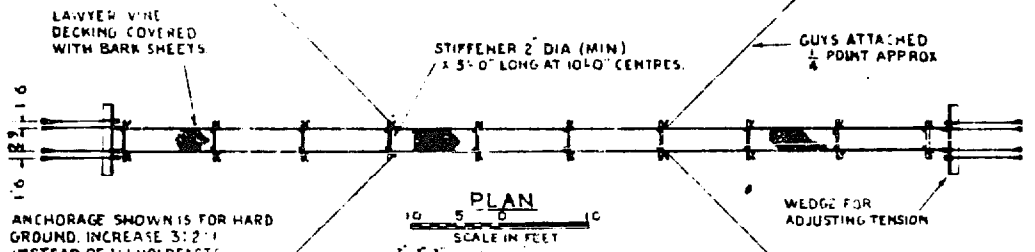
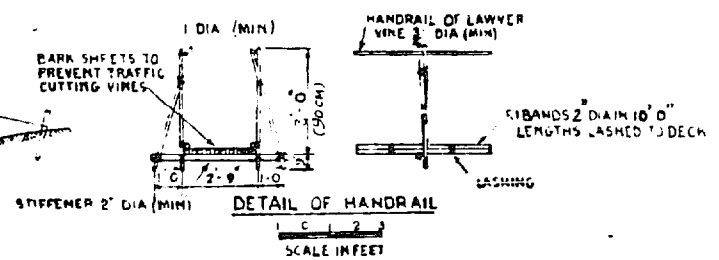
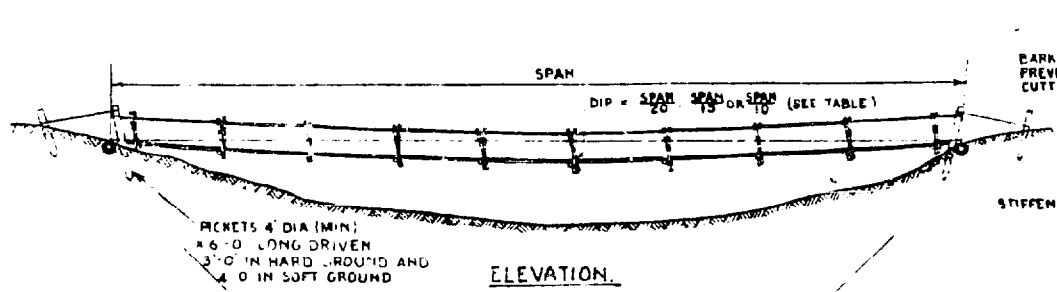
Use was made of short trees on either side of the bank and shear legs of 22,5 cm. (9-inch) diameter were linked and guyed with suitable vines.

AERIAL ROPEWAY.

- a) The main cable vine was 35 meters (110-feet) long of 2,5 cm (1-inch) diameter
- b) Construction took five man-days
- c) It easily supported one man on the sling.

LAWYER VINE CABLES. - Tests conducted on samples of vines show: -

- a) Yellow or brown covered vine gives the best results.
- b) The average breaking load is in ISO-units $3.9 c^2 N$ in which c is circumference in mm and the load is in N; in imperial units the average breaking load is $4.9 c^2$ cwt in which c = circumference in inches and the load is in long hundredweight.
- c) Allowing a factor of safety of 3 to 4 the safe load of the vines is in ISO-units $1.0 c^2 N$ (c is circumference in mm); in imperial units $1,25 c^2$ cwt (c is circumference in inches), i.e. the same as cordage.
- d) The wedge method of joining shown at Fig. 23 is as strong as the vine and gives 100 per cent efficiency. Normal cordage knots are not satisfactory.
- e) A minimum sharp bend over a spar should be reckoned as diameter of the vine $\times 6$; otherwise failure occurs under load.
- f) A normal type of picket holdfast is satisfactory for anchorages. The special type shown is equivalent in strength to the vine.
- g) The construction of suspension foot bridges of 30 meters (100-foot) span as shown have proved satisfactory.
- h) A jeep bridge of similar type has also been designed.



NOTE:-
FOR SPlicing AND JOINING OF MATS SEE DETAILS APPX A 24

NUMBER OF VINES - NORMAL DUTY

SIZE OF VINE (DIA) INCHES	SIZE OF VINE (DIA) MM	DIP = $\frac{\text{SPAN}}{10}$		DIP = $\frac{\text{SPAN}}{15}$		DIP = $\frac{\text{SPAN}}{20}$	
		SPAN		SPAN		SPAN	
13	330	8	11	15	22	30	40
16	406	5	7	9	13	18	24
19	483	3	5	6	9	12	16

feet

NUMBER OF VINES - HEAVY DUTY

SIZE OF VINE (DIA) INCHES	SIZE OF VINE (DIA) MM	DIP = $\frac{\text{SPAN}}{10}$		DIP = $\frac{\text{SPAN}}{15}$		DIP = $\frac{\text{SPAN}}{20}$	
		SPAN		SPAN		SPAN	
13	330	18	27	35	26		33
16	406	12	17	23	34	16	24
19	483	8	12	16	24	32	17

feet

NOTE:-
TO DETERMINE TENSION WHEN DESIGNING HOLDFAST ACCORDING TO LOAD CONDITIONS MULTIPLY NO OF VINES SHOWN IN TABLE BY VALUE GIVEN FOR VINE.

Figure 24. Lawyer vine - flat suspension bridge.

Design data to the flat suspension-footbridge with lawyer vines on page 98.

Live load	imperial units (original)	ISO-units (calculated)
1 man =	200 lbs	90 kg
men at 3 pace interval = normal duty =	27 lbs/ft	400 N/m
men at 1 pace interval = heavy duty =	80 lbs/ft	1200 N/m
<u>Vine load</u>		
Safe tension load (c = <u>circumference</u>)	1.25 c ² cwt c in inches	1.0 c ² N c in mm
allowable loads:	3.1 cwt on $\frac{1}{2}$ " \emptyset	1.6 kN on 13 mm \emptyset
for different <u>diameters</u> of vine:	4.9 cwt on $\frac{5}{8}$ " \emptyset	2.5 kN on 16 mm \emptyset
	6.9 cwt on $\frac{3}{4}$ " \emptyset	3.5 kN on 19 mm \emptyset
i.e. the allowable stress is:	15 cwt/square inch	12 N/mm ²
<u>Hold Fast</u> s		
size	6"	150 mm
in hard ground: load	1 ton	10 kN
in soft ground: load	0.5 ton	5 kN

Chapter 4.: Roads

- 4.1. - Bamboo Roadways,
from R.E.T.M. no. 17, section 48, pp. 95-96 p. 103
- 4.2. - Improvised Loom for Bamboo Nets,
from R.E.T.M. no. 17, section 73, p. 131 p. 105
- 4.3. - Bamboo mats for temporary roads,
from R.E.T.M. no. 17, section 49, p. 96-97 p. 106

All texts from R.E.T.M. (Royal Engineers Training Memorandum, 1945) by Courtesy Ministry of Defense, London, U.K.

4.1.

BAMBOO ROADWAYS.

From: RETM., no 17, section 48.
pag. 95-96.

Experience to date in the use of bamboo roadway has confirmed that it is a valuable expedient for keeping fair weather tracks open to light motor transport in wet weather. The following type has been found satisfactory.

1. Panels

- a. 270 cm-type (9-foot). The panels are 270 cm wide and made of 6 metre split bamboos wired together with 6 longitudinal double strands of 14 gauge (ϕ 2,032 mm) galvanized wire.
- b. 90 cm-type (3-foot). The panels are 90 cm wide by 6 metre long formed of 90 cm split bamboos wired together with 2 longitudinal double strands of 14 gauge (ϕ 2,032 mm) galvanized wire. These panels are used as wheel tracks.
- c. Bamboos - Bamboos are spaced at 10 cm centres. Bamboos over 4 cm ($1\frac{1}{2}$ -inch) diameter are split and laid with alternate round and flat sides upwards. Bamboos under 4 cm diameter are laid whole, and graded so that no major inequality occurs in the panel.
- d. Wiring - Longitudinal holding wires are of 2 strands of 14 SWG (Standard Wire Gauge = 2,032 mm) laid with one strand above and one below each bamboo slat and twisted up tight in between so as to grip the bamboo slats firmly. The wires project 45 cm (18 inches) beyond the end of the panels to facilitate the tying together of panels when laid.
- e. Particular attention must be paid to the following points:
 - (1) Proper tightening of binding wires
 - (11) Proper grading of bamboos in each panel.

As a general guide the 270 cm panels are for use on tracks for 750 kgs vehicle and on sleep portions of jeep tracks. The 90 cm panels are for jeep tracks.

2. Pickets

Pickets are short angle iron with ends flattened out and bent over so as to fit over a bamboo slat on the line of the outer binding wire.

3. Ribands

Ribands are of 9 mm ($3/8$ ") or 6 mm ($1/4$ ") round iron rod or 8 gauge (ϕ 1,1605 mm) or larger galvanized wire. The rods are hooked together by cold bending them on the site at the time of laying.

Ribands are laid along the outer line of pickets and held down by the pickets. Their function is to hold panels firmly down on to the ground and prevent creeping.

Assembly.

270 cm, (9 foot) track - This is laid with four pickets per panel on flat ground and six pickets per panel on slopes, increasing to eight pickets per panel on very steep inclines. Two ribands are used along each line of picket.

90 cm, (3 foot) track - Panels are laid double, providing two wheel tracks at 135 cm centres. Each panel is picketed to the scale given in (a) above and has two ribands.

Laying the panel. - Whenever possible the following rules should be observed in the laying of panels. If these are not adhered to the roadway cannot be expected to last: -

- a) The formation must be properly drained and smoothed out.
- b) Panels must be stretched tight.
- c) Panels must be picketed down as in para .
- d) The longitudinal ribands 9mm(3/8") or 6mm (1/4") round iron or thick galvanized iron wire must be tight and securely fixed down by the pickets.

Maintenance

- Bamboo roadway must be constantly maintained, and 25 per cent spare panels should be allotted for overlaying on bad portions.

4.2.

IMPROVISED LOOM FOR BAMBOO NETS.

From: RETM., no 17, section 73.
pag.13

Fig. 36 gives details of a bush loom suitable for weaving bamboo strips and other natural materials into serviceable mats and nets. Cross weave is obtained by passing a ball of material between the front and rear strips as the bar is alternately raised and lowered.

At completion of looming the ends are tied off. The size of the mesh can be varied by altering the spacing between the bars and by closer feeding of the material.

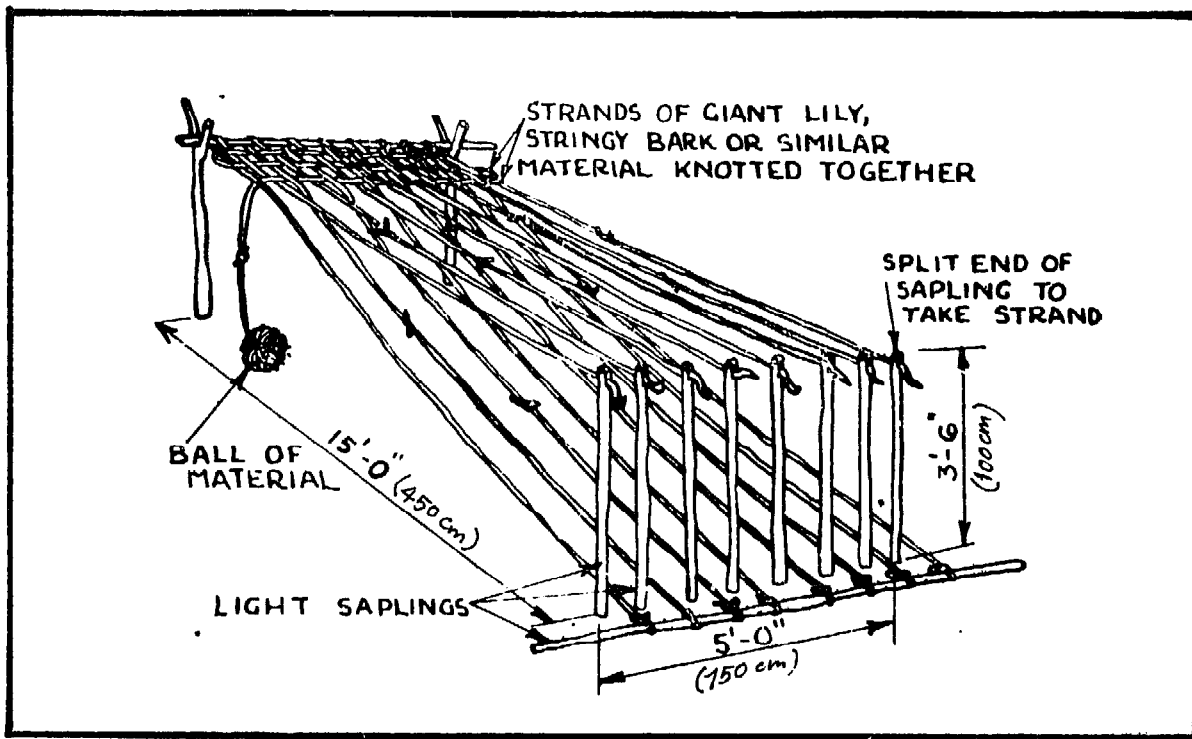
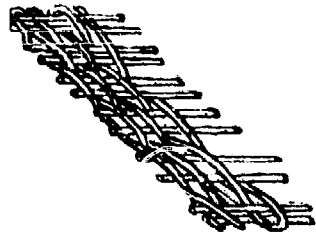
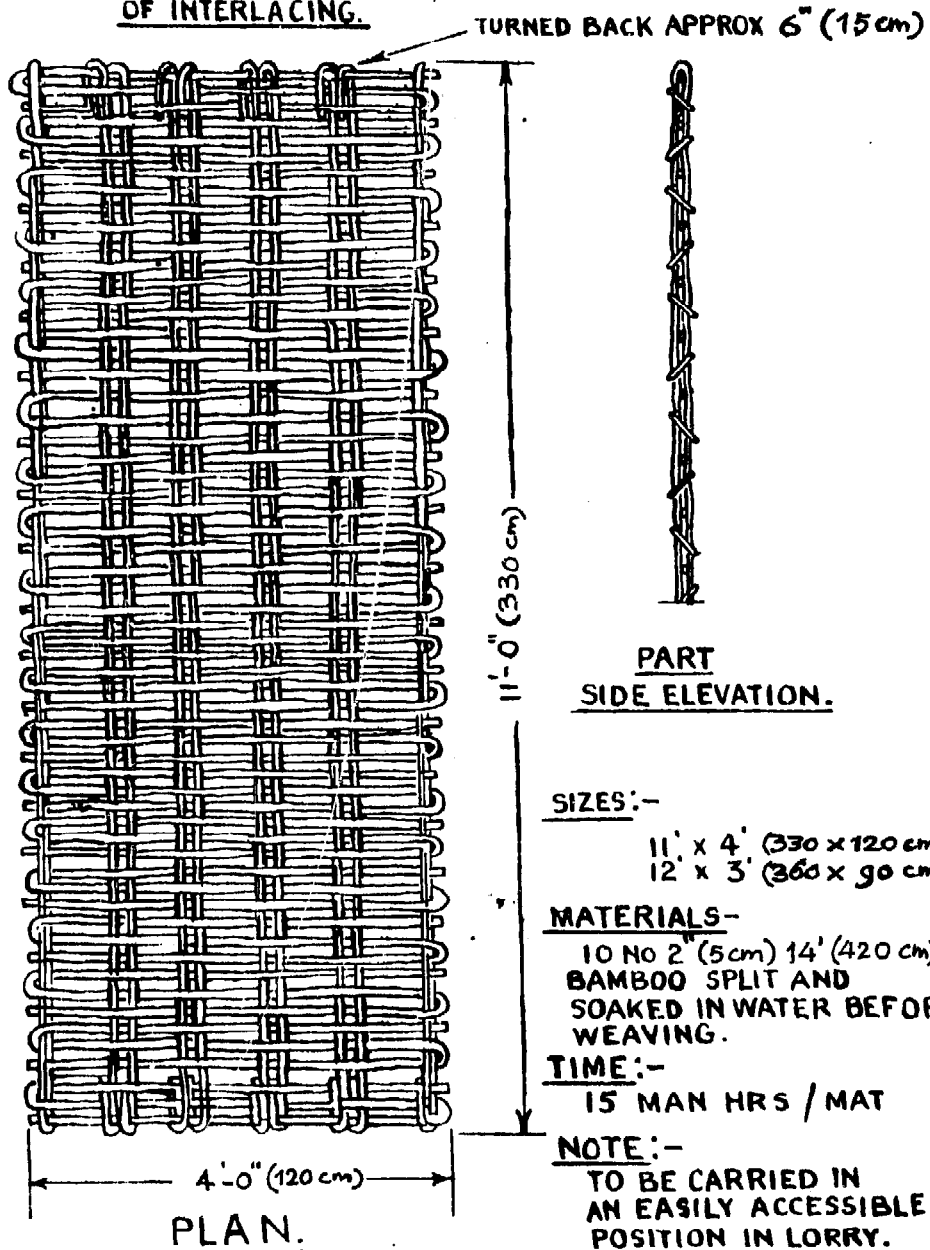


Figure 36. Perspective of loom.

4.3.



SECTION
SHOWING METHOD
OF INTERLACING.



SIZES:-

11' x 4' (330 x 120 cm)
12' x 3' (360 x 90 cm) OR

MATERIALS:-

10 No 2 (5 cm) 14' (420 cm) LONG
BAMBOO SPLIT AND
SOAKED IN WATER BEFORE
WEAVING.

TIME:-

15 MAN HRS / MAT

NOTE:-

TO BE CARRIED IN
AN EASILY ACCESSIBLE
POSITION IN LORRY.

Figure 35. Bamboo mats for temporary roads.

BAMBOO MATS FOR TEMPORARY ROADS.

From: RETM., no 17, section 49.
page 96.

1. Description. - For details see Fig. 35

2. Tests

- a) On firm ground - After the passage of 1,600 vehicles in one month the mats showed little wear and would probably remain serviceable for a further three months.
- b) of sand - The passage of 850 vehicles in a fortnight did not affect the mats. Performance on deep sand has not yet been tested.
- c) On mud - 1,200 vehicles passed over mats laid on made up mud pits. The mats broke up when vehicles became axle deep.

Chapter 5.: Boats and Rafts

- 5.1. - Improvised Rafts and Ferries,
from R.E.T.M. no. 17, section 16 pp. 40-43 p. 111
- 5.2. - Bamboo Rafts,
from the former Royal Dutch Indian Army
(1939) p. 114

All texts from R.E.T.M. (Royal Engineers Training Memorandum,
1945) by Courtesy Ministry of Defense, London, U.K.

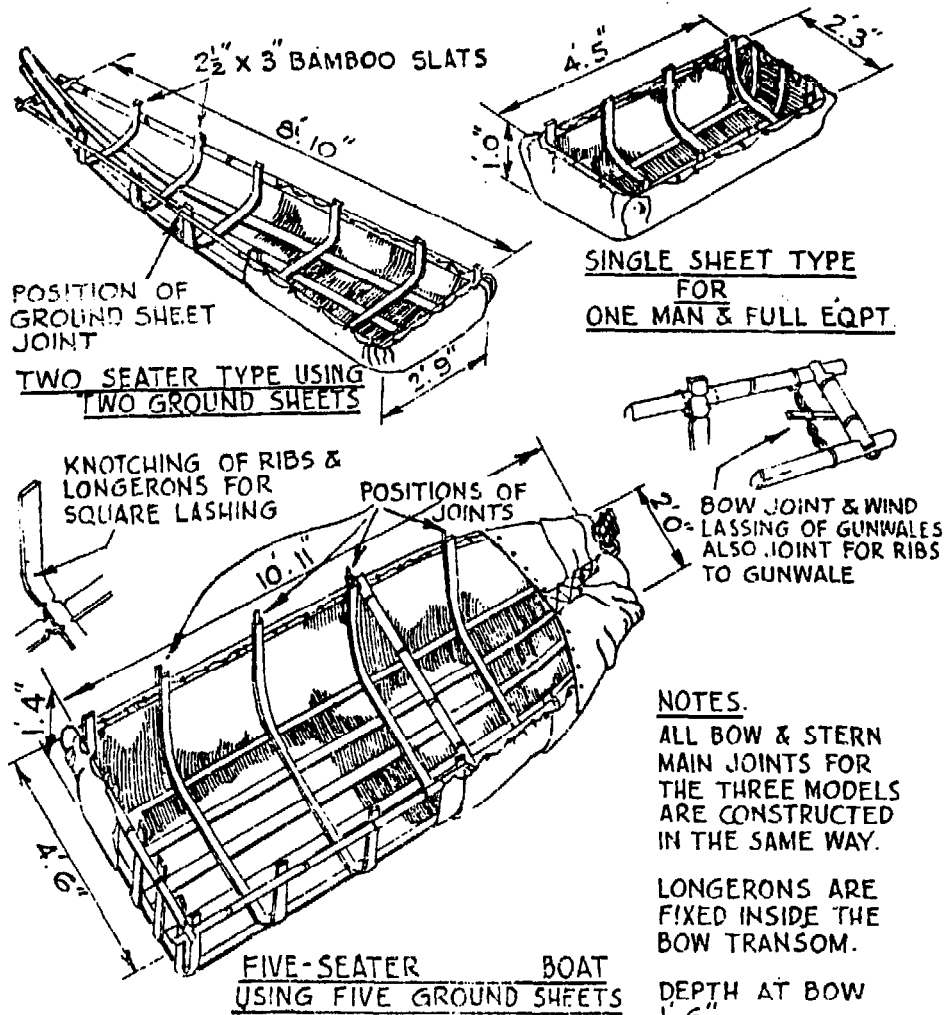
5.1.

IMPROVISED RAFTS AND FERRIES.

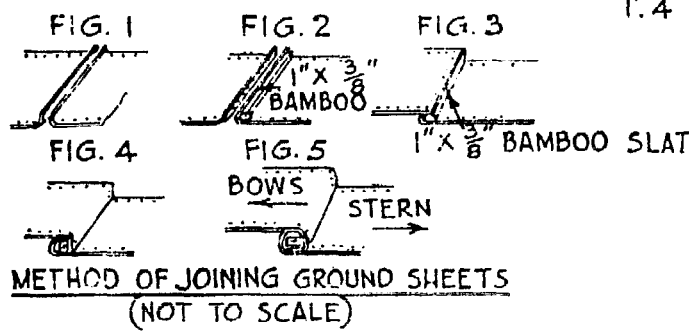
From: RETM., no. 17, section 16,
pag. 40-43

1. Improvised boats.

The figure below shows three types of boats improvised from ground sheets and bamboo. Thin bamboo strips must be inserted between the longitudinal slats and ground sheets to prevent wear of the canvas.



NOTES.
ALL BOW & STERN MAIN JOINTS FOR THE THREE MODELS ARE CONSTRUCTED IN THE SAME WAY.
LONGERONS ARE FIXED INSIDE THE BOW TRANSOM.
DEPTH AT BOW 1.6"
DEPTH AT STERN 1.4"



BAMBOO MATS ARE LAID WITH 6" OVERLAP IN WIDTH & 2' IN LENGTH. TARPULINS 14' X 21' WITH 1' 0" OVERLAP. 3'-6" MARGIN FORMS GUNWALE ALL JOINTS ARE FIRMLY LASHED.

BAMBOO MATS INSIDE TARPULIN



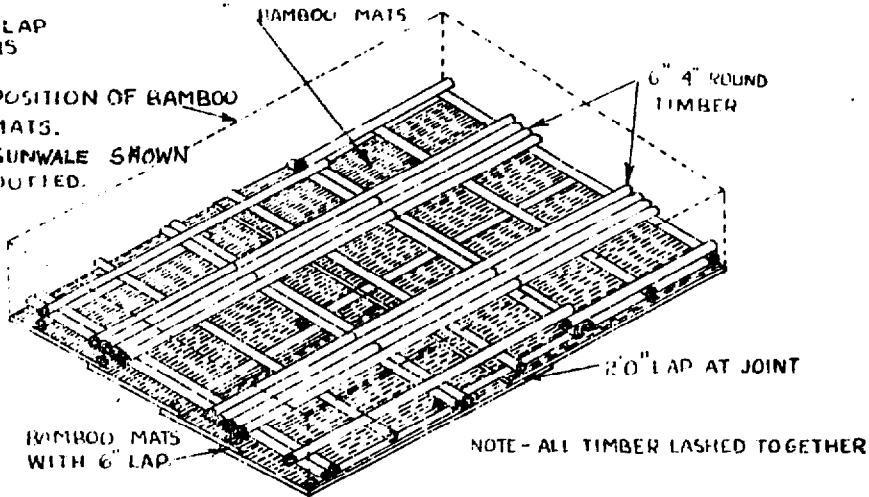
LONGITUDINAL SECTION

BAMBOO MATS INSIDE TARPULIN



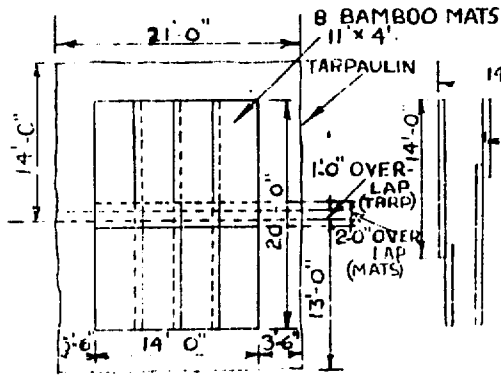
CROSS SECTION

POSITION OF BAMBOO MATS. GUNWALE SHOWN DOTTED.

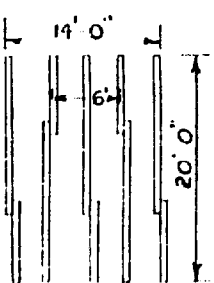


- 4" = 10cm.
- 6" = 15cm.
- 1' 0" = 30cm.
- 2' 0" = 60cm.
- 3' 6" = 105cm.
- 4' = 120cm.
- 7' 0" = 210cm.
- 11' = 330cm.
- 12' = 360cm.
- 13' = 390cm.
- 14' = 420cm.
- 20' 0" = 600cm.
- 21' 0" = 630cm.

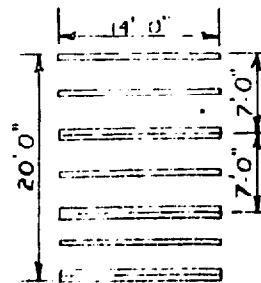
ISOMETRIC VIEW
SCALE - DIAGRAMMATIC



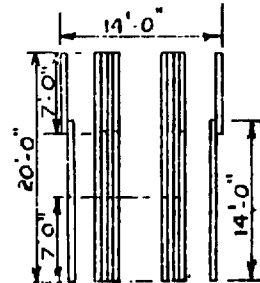
TARPULINS & BAMBOO MATS



FIRST LAYER



SECOND LAYER



THIRD LAYER
(ROADWAY)

Figure 38. An improvised raft.

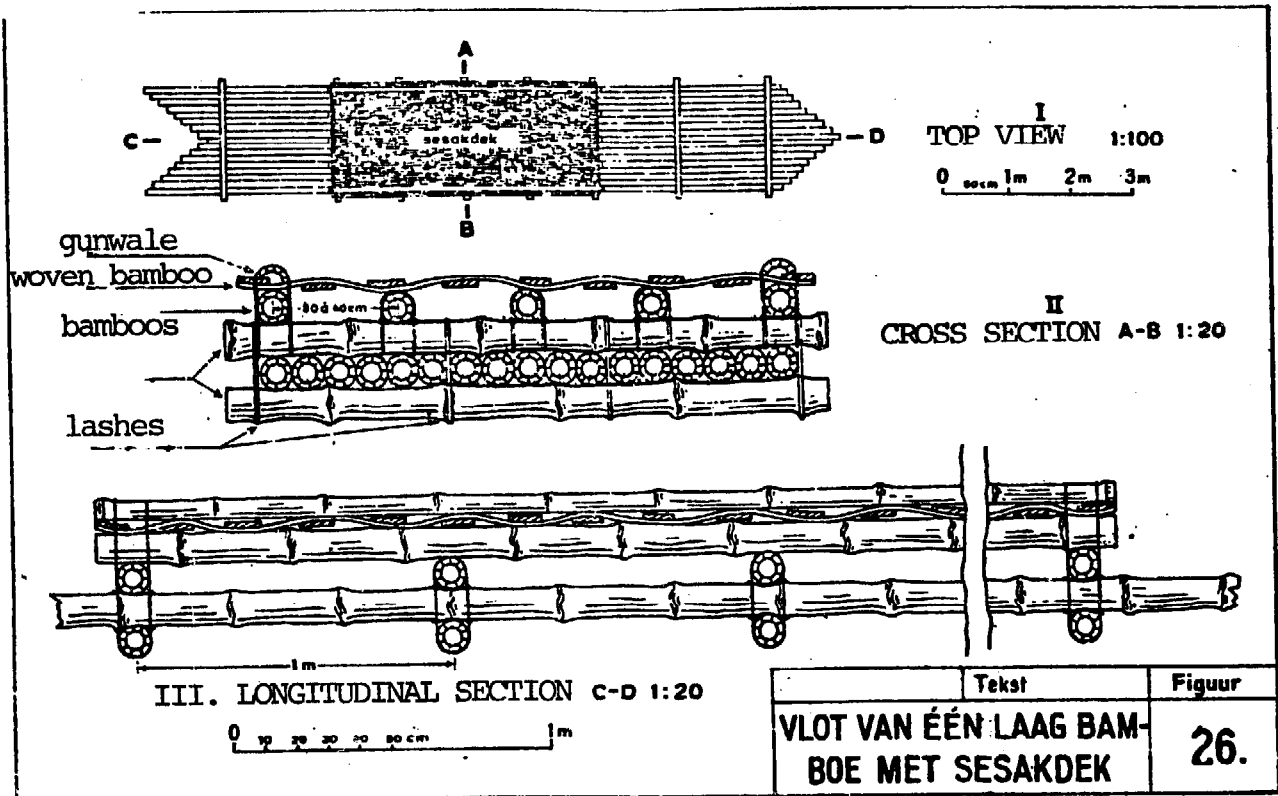
2. An improvised raft.

- (a) Fig 38 shows a raft of lashed timber framework with an external skin supporting two timber trackways.
- (b) The raft skin comprises an outer layer of tarpaulin and an inner layer of bamboo mat giving support to the canvas, and stiffness to the gunwales.
- (c) To obtain adequate stability the length and width of the raft should not be less than double those of the vehicle or load to be carried. Construction should begin with a part of the tarpaulin in the water supported by pickets; the mats are then placed, and the timber framework built up inside progressively, booming out the raft as construction proceeds.
The raft floor bellies under load, enabling it to be floated close in-shore.

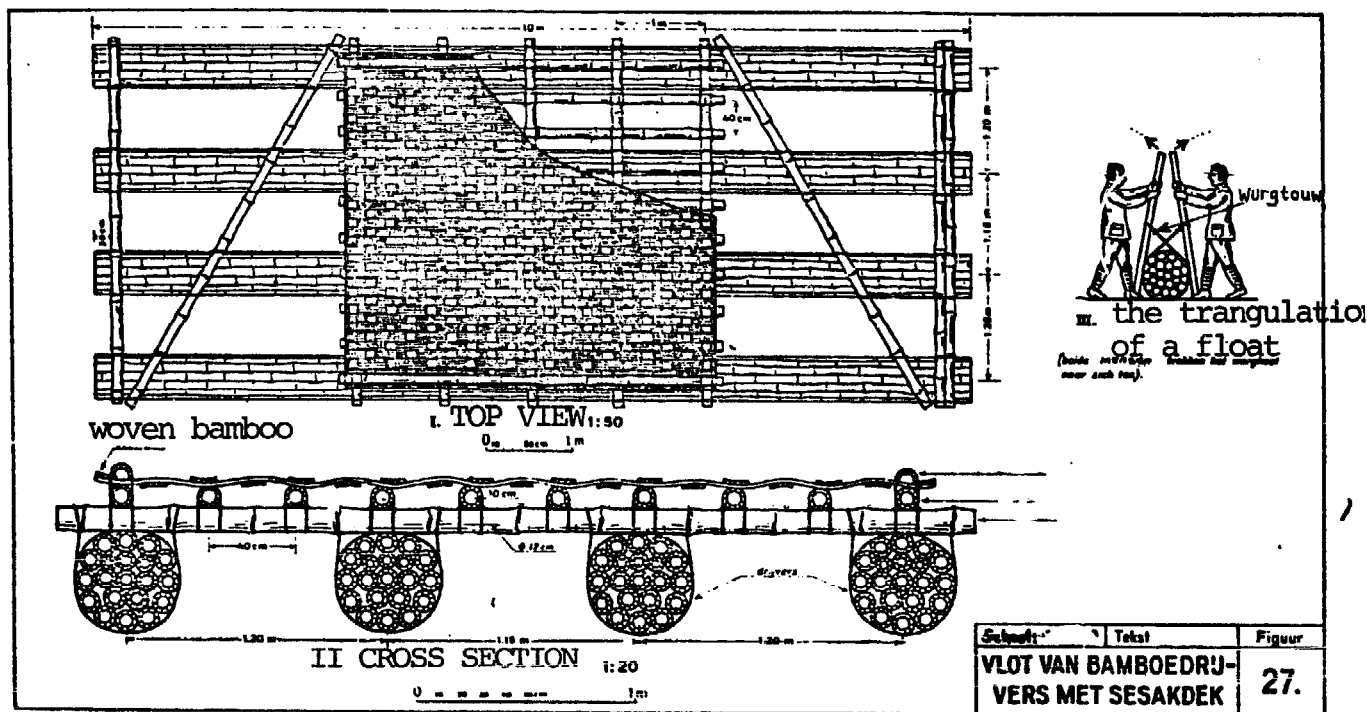
3. A large improvised raft.

Great use has been made of large improvised rafts, constructed from boats built into a locally cut bamboo or sappling frame wholly wrapped in a 12x12 mtrs (40'x40') tarpaulin and decked down. Employing five to nine boats and powered by two 9.8 or 22 hp Johnson outboard motors, these rafts will carry 50 men or 16 mules, the carrying capacity being limited only by deck space. This type of raft is particularly usefull, since all the stores necessary can be dropped from the air, and they take up quite a small space in the aircraft.

5.2.



Bamboo-raft



Bamboo-raft with floats

Bamboo rafts

From the former Royal Dutch Indian Army (1939)
(abstract by the editor)

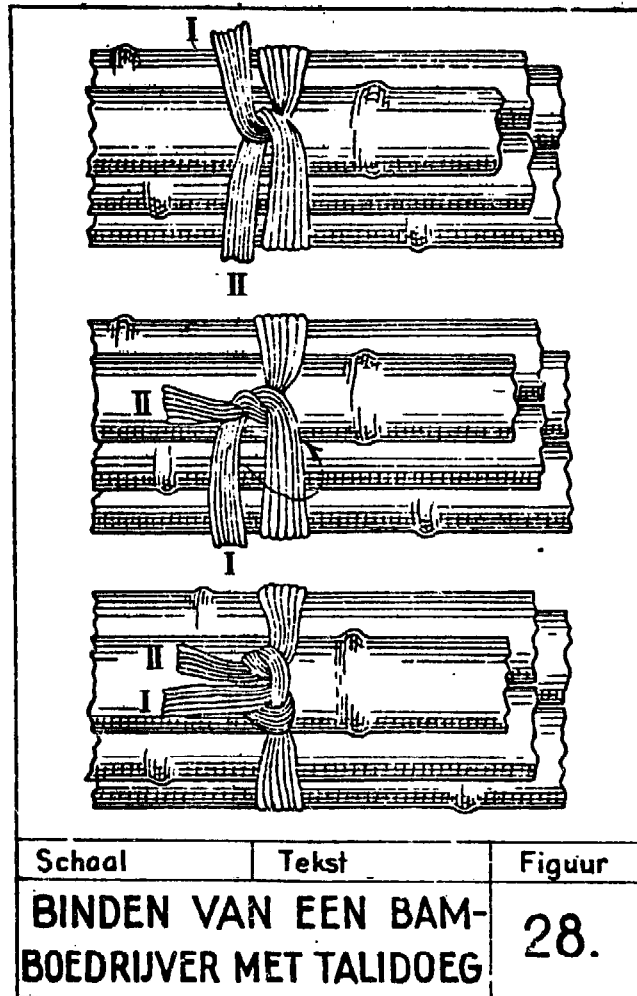
Figure 26 shows a bamboo raft, in which the bamboos are joint together with lashes. On top of the raft a floor matting of woven split bamboo is used.

Figure 27 shows another bamboo raft, with floats. The pay-load on this raft might be about 1100 kg (2400 lbs). The floats are strangled together by two people, moving the strangling poles as indicated by the arrows in fig. 27 III.

This should be done at distances of 1.50 or 2.00 m. After each strangulation the float is tied with rope, or with wire, or with palm-tree-fibre (see page 116).

The load, which can be carried by floating bamboo, is given in old military documents as 250 kg (550 lbs) per m^3 volume of bamboo culms. This load consists out of the pay-load plus the dead-load of the bamboos (e.g. 2 to 5 kg/m) and the woven split bamboo ($10 \text{ kg}/m^2$). To be safe, increase the calculated length and width of the raft with 1 m each.

How to tie bamboos with palm-tree-fibre
 (Indian name: TALI DOEG)



Chapter 6: Water supply

- 6.1. - Pipes and Troughs
by McClure p. 119
- 6.2. - Improvised Water Supply
REIM no. 17 section 68 (1945) p. 124 p. 120
- 6.3. - Bamboo for water supply
REIM no. 11 section 47 (1944) p. 48 p. 121
- 6.4. - New Development in Bamboo Water Supply,
on the Tanzania project, and the book
by Mr. Kick van den Heuvel p. 122
- 6.5. - Water Pipes from Bamboo in Mezan Teferi,
Ethiopia,
from A.T. vol. 1 no. 2, 1974 p. 123
- 6.6. - A traditional Bamboo Pump,
from A.T. vol. 5, no. 4, 1979 p. 126
- 6.7. - Well Casing and Screens from Single
Stalks of Bamboo,
from A.T. vol. 5 no. 1, 1978 p. 128

Pipes and Troughs

The culms of certain bamboos, with diaphragms removed, serve admirably for the fabrication of pipes and troughs.

Longitudinal halves of bamboo culms make very satisfactory eave troughs. Where rainfall is light and water must be conserved, they are used to collect rainwater from the roof and send it into a barrel or cistern for storage. Where rainfall is heavy, they are used to carry the water from the roof to a distant point, in order to avoid excessive dampness around the house.

Under certain circumstances wash water from the kitchen may be disposed of through bamboo pipes or troughs. For this purpose a sloping trough is more practical than a pipe since it is more easily prepared and, if clogged, may be cleared with greater facility.

Longitudinal halves of bamboo culms with the diaphragms removed make suitable conduits for bringing water for domestic use from its source to the house by gravity

In Japan, closed-pipe water systems are constructed of bamboo but it is very difficult to make the joints leakproof.

Underground drainage may be effected by means of bamboo pipes of simple construction. The steps in preparing the bamboo for such use are (1) halving the culms, (2) removing the diaphragms from one half to make the lower section of the drain pipe, (3) cutting notches in the edge of the other half to permit the free entrance of water, (4) treating the two halves with preservative (5- to 10-percent pentachlorophenol in light oil), (5) placing them together again in their original relation, and (6) binding them together with wire. Such drains may be extended to any length by placing the smaller tip end of one pipe into the larger basal end of the succeeding one.

To be suited for the uses just described, the bamboo culms should have a diameter large enough to give the required carrying capacity, and the walls should be thick enough to prevent collapse under use.

6.2.

IMPROVISED WATER SUPPLY

From: RETM., no. 17, section 68 (1945)
page 124

1. Rainwater runoff.

In tropical areas particularly, prepared catchment runoffs can provide a considerable supply of water and have the advantage of purity.

Roof areas are a normal source of water in many parts of the world. Improvised catchments constructed of tarpaulins and ground sheets can be used while still providing cover.

A handy guide for assessing the yield of a catchment or runoff is given by the following: for each 5 cm (2") of rainfall, 1 square meter (foot) of catchment will yield approximately 50 liters (1 gallon) of water.

Water may be collected from the coconut palms by attachment to the trunk of palm leaves, twisted rattan, or thin collars to collect the runoff during periods of rainfall. The amount of water that can be collected by this method is considerable if a number of trees are used and the flow diverted into suitable containers.

2. The use of bamboo pipes for water supply.

An alternative method of joining bamboo lengths is illustrated by the following report:

A water pipeline 180 mtr long was constructed in China by Americans, and does the work of 18 mm ($\frac{3}{4}$ ") metal pipe. It was built in a matter of hours and is arranged so that it is gravity fed, being supported on bamboo tripods where necessary. The joint piths of 450 cm (15') to 600 cm (20') sections of bamboo were rammed out, and short sections of metal pipe were used to make connections. The ends of the bamboo sections were reamed to fit and caulked to make the connections watertight. A continuous flow of spring water prevents cracking, and no leaks appeared anywhere in the pipe.

6.3.

BAMBOO FOR WATER SUPPLY

From: RETM., no. 11, section 47 (1944)
page 48.

By the use of bamboo as pipes, water can be brought to villages from streams or springs, provided it is possible to preserve a reasonable constant gradient. Almost invariably pipes are supported on sheers, since this method enables control to be kept over gradient. The method of preparation is to chop the bamboos with a "V" cut at each ring and remove the fibre diaphragm. Jointing is by means of scarfing the ends of the bamboo in opposite directions and setting one end into the other. Water can be carried long distances by this primitive method.

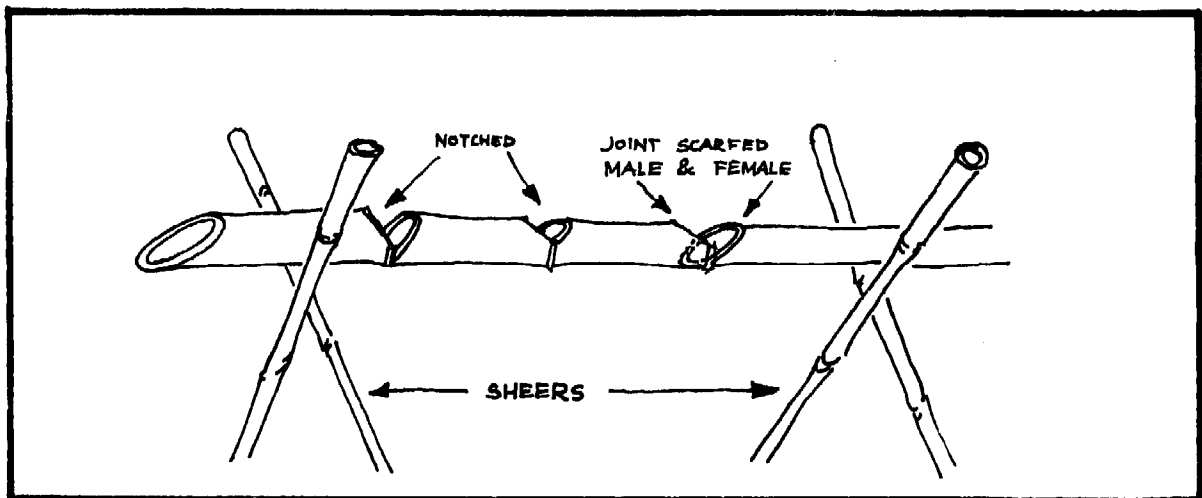


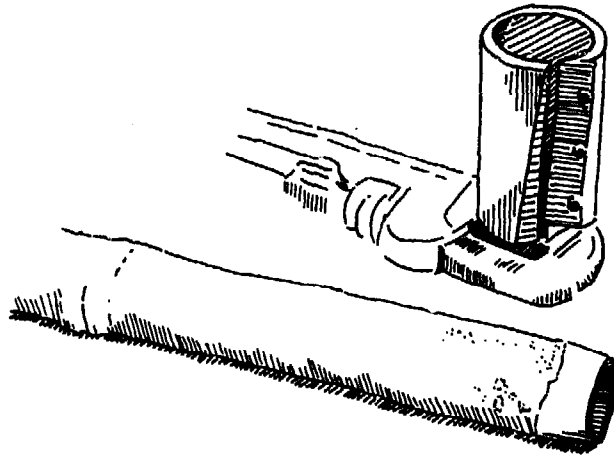
Figure 39. Bamboo waterpipe on sheers.

6.4.

New Development in Bamboo Water Supply

In 1974 in Tanzania a project on wood and bamboo for rural water supply has started. A first important result is a good and simple joint for bamboo waterpipes. (abstract by the editor)

1. Sort the bamboos to size, in such a way that ends with the same diameter join each other.
2. Cut the ends at a right angle.
3. The bamboo is shaped with a knife or with a kind of pencil sharpener (see figure) to make the bamboo suitable for insertion into the plastic joint.
4. The joint is made with tubes, long 20 cm, of PVC (poly vinyl chloride) or PE (polythene = polyethylene). The many different diameters you have in stock, the better the chance that one will fit.
5. Add a PVC paste, called TANGIT, to make the joint water tight.



Title: Wood and Bamboo for rural water supply.
Author: Kick van den Heuvel.
ISBN 90 6275 0583
Delft University Press, 1981, 76 pp.
For sale with TOOL, Amsterdam, and ITDG, London

Water Pipes from Bamboo in Mezan Teferi, Ethiopia

John Morgan

Mezan Teferi is a sparsely settled region some 450 kilometers from Addis Ababa, accessible by dry-weather road only for about 4 months of the year. The people are mostly subsistence farmers using the "shifting cultivation" technique of macheteing out the bush growth, letting it dry, and then firing it, and finally cultivating with ox-drawn plough or a digging hoe.

With this technique, the people find a piece of land "worn out" in only two or three years. Searching for fresh land to cultivate, they have been farming very steep hillsides and wastefully clearing the few original forest areas still extant on the highest hills, which should be protected to recharge the aquifers.

Appropriate technologies are needed to stop this environmental deterioration, by establishing more intensive and permanent agriculture on less total cultivated area. Irrigation is clearly needed, as there is a dry season and occasional dry years in this area. In the mild climate here, an irrigated field can produce three crops annually.

In response to these environmental concerns, and to reduce the human drudgery of carrying water for domestic use, we began to test the use of bamboo for water piping. Bamboo has long been known as a piping material in Asia, and it is reported that bamboo water pipes were used in the time of the Ethiopian Emperor Menelik in the last century.

Making the Drill

Every 30-80 cm. along the bamboo stem are inter-nodes which interrupt the hollow. These must be drilled through if the stem is to be useful as piping. Reports from Taiwan, where bamboo piping is used, suggested punching out the inter-nodes with a sharpened piece of pipe, but we found that this technique seemed to split the bamboo culms. Our Ethiopian bamboo may have thinner walls than the Taiwan species; also, the sharpened pipe blade edge was quick to turn in and had to be re-sharpened laboriously.

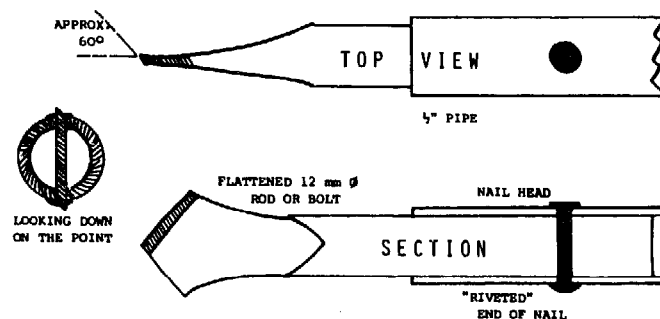
We hit on another solution: fabricating our own simple drilling bit. To make the bit, we first flattened out one end of a piece of 12 mm mild steel rod (a bolt would also work) to the necessary width. The smallest inside diameter of our bamboo was about 3.5 mm at the bases. The rod was flattened by simply hammering it against an anvil. A vice or heavy axe head would also serve if no anvil were available. This "cold working" of the steel probably tends to harden it somewhat.

Next, the flattened rod was ground to the necessary configuration. We used a grinding wheel, but a hand file could also be used. The trick is to grind the two cutting faces in complementary planes so that each is cutting properly when the blade is rotated.

John Morgan is a participant in the Village Technology Innovation Experiment, Addis Ababa.

The completed drill tip is mounted into a standard 6-meter length of $\frac{1}{2}$ " water pipe. Drilling alternately from both ends of the bamboo with this pipe, we can drill out a length of bamboo of about 12 meters. If the length of bamboo sections available is less, the $\frac{1}{2}$ " pipe can be correspondingly shortened.

To fix the drill bit in the pipe, a 4 mm hole was drilled transversely through both the pipe and the stem of the drill bit. A tight-fitting nail was inserted in the hole and cut off with a hacksaw, so that about 4 mm of the nail stuck out from the pipe. The head of the nail is then pressed against the anvil and the protruding cut-off section is hammered down like a rivet. The drill is then complete (see Figure 1).



1. Details of drill bit design (not to scale)

The Drilling Operation

A minimum of three people are needed for the drilling operation. One holds the bamboo to be drilled, while the second turns the pipe drill stem using a standard pipe wrench. The third person supports the end of the pipe drill stem, and pushes the drill into the bamboo. For pushing, we found a cut-off piece of bamboo with the inter-node intact made a fine "thrust bearing".

The operation is fast and easy. As each node is pierced, the "thrustrer" pushes the bit into the bamboo to the next node, and the drilling continues. Three workers can easily bore out a dozen 7-meter bamboo poles in one hour. We found that this work was easy and fun even for young students.



2. The drilling operation

Siting the Pipeline

We took our water for the experimental system from a stream, simply tapping the piping into an existing small dam of concrete and timber (Figure 3). Much simpler dams could of course be made from sod, stones or logs.

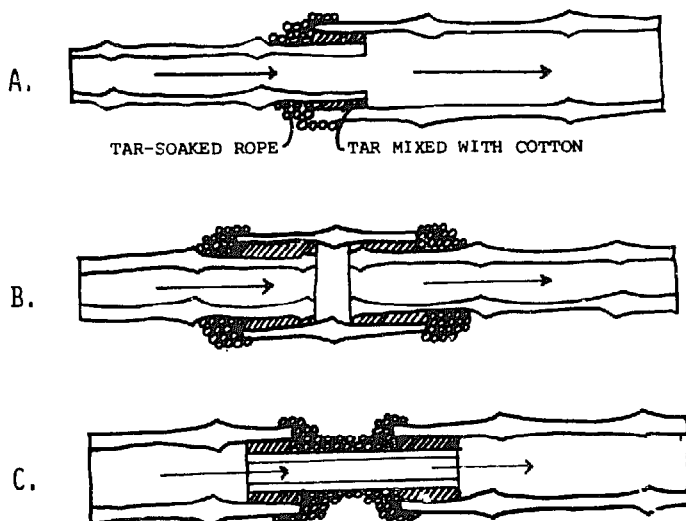


3. Bamboo piping tapping out of a small dam

Since the flow of water depends on gravity, the greater the drop or head through the pipeline, the greater the flow. Such a system is most useful where the natural water course drops steeply, as at a waterfall. However, the bamboo costs little or nothing in many areas, and this piping can also be useful in relatively level terrain by simply tapping a stream up-river, and piping the water farther to get a good gravity head at the point of use.

Installing the Pipeline

The pipe sections are either mounted on supports above ground or laid in excavated trenches, depending on the terrain that must be crossed. Supports can be made of brush, limbs, sod or rocks found at the site. As the pipe is installed, a constant slope can be maintained working with a line level from the water source.



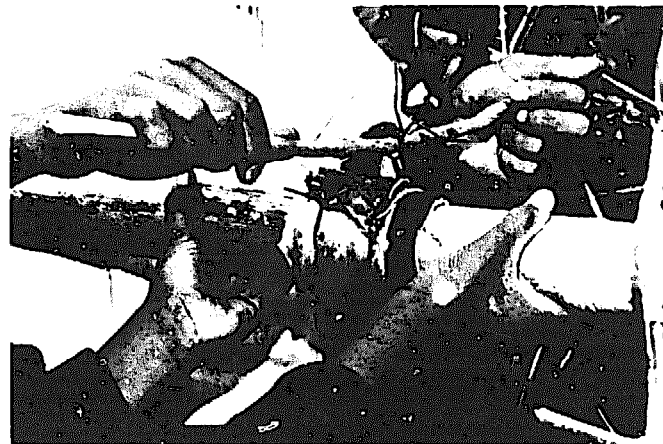
4. Three joints for bamboo piping, from Village Technology Handbook (VITA), "Bamboo Water Systems".

Alternatively, the appropriate slope can be judged by observing the flow through the pipe as it is raised and lowered. The pipe is mounted in approximate position, then joined to the preceding section. There are several jointing possibilities, as shown in Figure 4. If the bamboo sections are long

enough and taper enough through their length, each section can be inserted into the preceding one (drawing A). Or, extra large bamboo sections can be found to use as "unions" around two smaller sections (drawing B), or smaller pieces used to unite two larger sections (drawing C).

As our bamboo was not the right size for any of these joining methods, we developed a fourth type of joint. The sections to be joined are held together and a piece of cow-hide is wrapped tightly twice around the joint. The hide is first soaked overnight in water to make it pliable, and so that it will shrink around the pipe joint when it dries out.

The wrapped joint is then sealed tight with two pieces of 1-2 mm wire, preferably galvanized wire. The wire can be drawn tight with pliers, or tightened with a stick. The ends of the twisted wires are snipped off close to the pipe, to discourage pilfering. The joints might also be lashed with rope, twine or vines.



5. Using a stick to tighten tie-wire on a joint

In Taiwan, bamboo piping serves for 3 or 4 years, and sometimes lasts for 5 or 6 years. It is best preserved when full of water, buried in the earth or wrapped with layers of leaves and earth. We don't as yet know how long the cow-hide joints will serve. Old automobile inner tubes cut in sections could provide a strong, long-lasting alternative to the leather, but these were not readily available in Mezan Teferi.

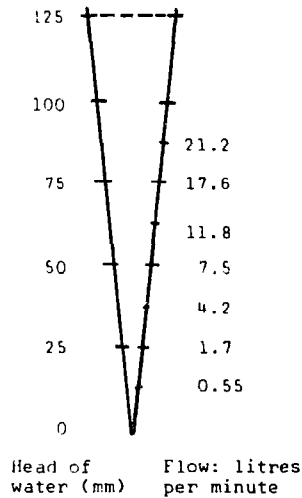
There is a special advantage to the leather (or rubber) joint system, in that the line of piping can be curved a bit at each joint to follow the contour of the land. We found that with the inserted joints, attempts to curve the pipeline resulted in cracking the outer bamboo. However, it may be that by steaming the bamboo, pipe joints could be easily bent.

Measuring the Flow

It is possible to let the flow run into a graduated container, such as a bucket, for a measured period of time (e.g. 15 seconds). Then the flow rate per second or minute can be calculated by multiplying.

However, when you don't have a graduated container, time-piece, or much confidence with multiplication, a simple V-notch gauge is fast and easy to make and use from an empty oil or petrol tin (see Figure 6). We found that a sharp knife could cut our tin can accurately. The flow is measured

by simply noting up to which horizontal line the water level reaches as it spills through the notch. We also included in our "gauge" a left-hand scale suggesting what minimum levels of constant flow were needed to irrigate 2,500, 5,000 and 10,000 square meters of land.

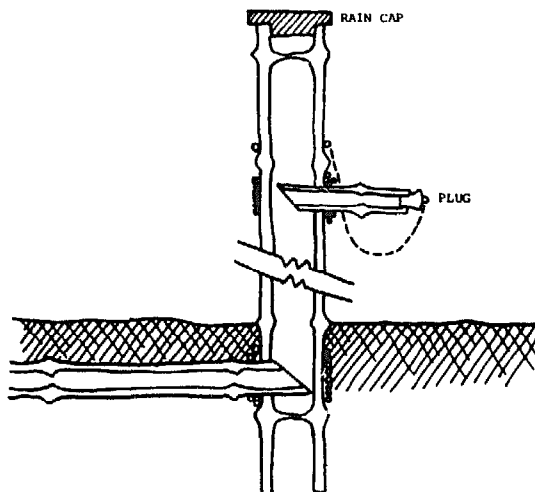


6. Measuring flow with V-notch wier; and design of V-notch, from Water Treatment and Sanitation (ITDG)

Potentials of Bamboo Piping

With the bamboo species common in Ethiopia, *Arundinaria alpina*, a flow of 24 litres per minute can be obtained which is enough to supply the water needs of one hectare of land.

Village people are frugal in their use of water for the household: perhaps only 20 litres per person per day. At this rate one 40 mm bamboo pipe to a village tap could serve up to 500 people! A design for a simple tap using bamboo elements is shown in Figure 7.



7. A rudimentary public fountain of bamboo, modified from Village Technology Handbook.

A Traditional Bamboo Pump

from the Information/Documentation Center, DTC-ITB, P.O. Box 276, Bandung, Indonesia

In 1977 a bamboo hand pump was discovered in the Ciamis area of Western Java, Indonesia. On investigation, it was found to be so interesting that it was brought to Bandung for further testing and dissemination. The pump's history was not quite clear; it seemed that the design had been passed on from pumpmaker to pumpmaker through the generations. One of the pumpmakers interviewed, Mr Yussuf, had started making the pump in 1956 and at the last count, in 1978, he had supplied 25 families with a bamboo pump. The average age of pumps in the area was four years, although one had survived six. Light maintenance measures were performed by the villagers themselves, but Mr Yussuf dealt with more serious repairs.

Technical data

Materials: green or black bamboo, wood, strings, rubber
 Maximal depth: 8 metres
 Output: 0.4 l/stroke
 Costs: US\$4-5

How it works

The pump is made entirely from materials readily-available all over the Javanese countryside – wood for the frame and handle, black or green bamboo for the suction pipes and cylinder, tyre rubber for the valves, leather for the piston and some nuts and bolts. The tools needed to make the pump are also simple: knives, a scraper, saw and hammer. It operates by a suck-press system, which can be understood from Fig.1.

Pushing the handle *down* brings the piston up and sucks water through rubber valve A in the cylinder house, while rubber valve C is closed. Lifting the handle *up* brings the piston down and presses water from the cylinder house through pipe B and rubber valve C out of the pump.

Field tests and results

Further investigation of new bamboo pump installations brought to light some important points concerning installation and operation:

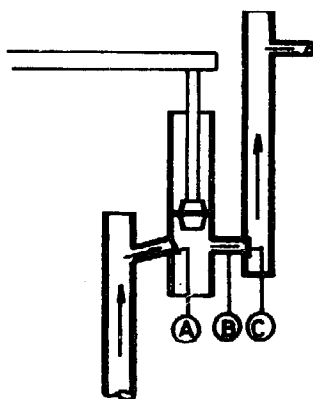


Fig.1 The 'suck-press' system.

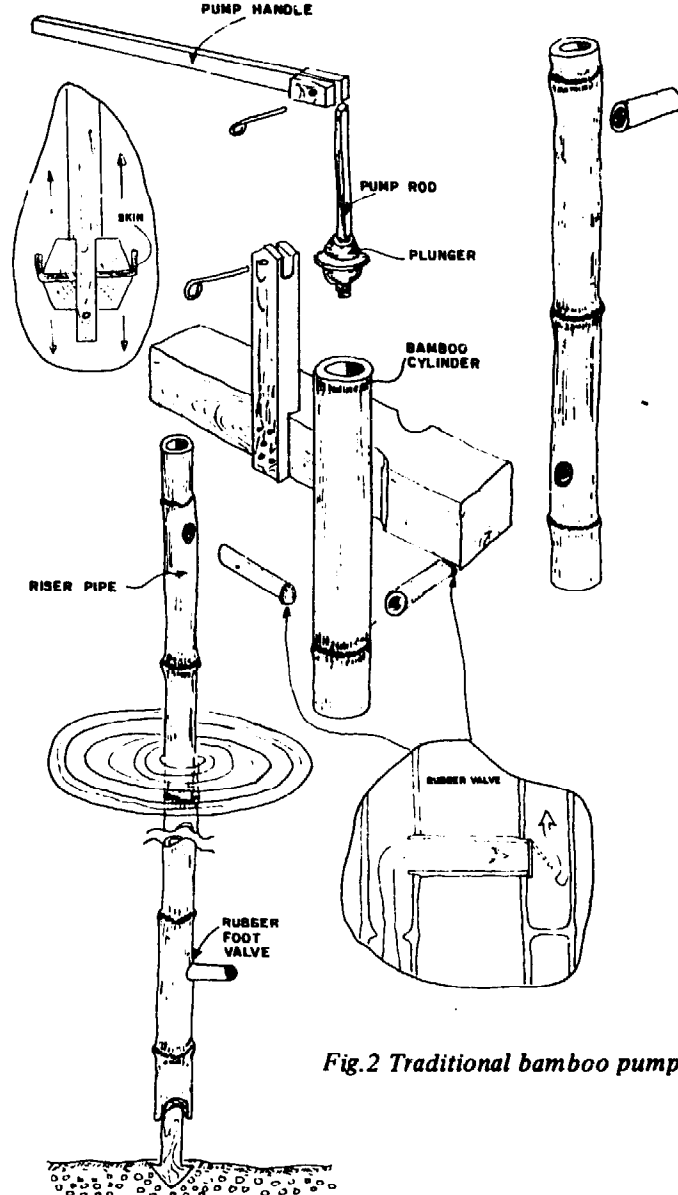


Fig.2 Traditional bamboo pump.

1. Several types of bamboo can be used, but the bamboo must be cylindrical, with a diameter of 7-8 cm, and it must be strong.
2. If the pump is not in use (for instance during the night) the water level in the suction pipe will lower and in the morning priming will be necessary. It would be a good idea to add a bottom valve, as shown in Fig.2.
3. The bamboo should be pre-treated by keeping it wet for one to two months. This is done in order to remove the bad taste and smell from the bamboo. If this is not done bad-smelling water should be expected during the first pump strikes.
4. The pump should not be exposed to direct sunlight, because this will dry out the bamboo and cause cracks.
5. A weak point of the pump is the piston. The leather should be replaced around once a year if it is in constant use, and once every two years for less intensive use.

After three months of monitoring eight new installations in private households in the village of Cidadap, it was found that five pump owners still maintained their pump with good results. They had performed small repairs by themselves and were quite content. Three pump-owners had



Fig.3 The pump in action.

demolished their pumps because of the bad smell of the water. These experiences, combined with those from Ciamis, where the pumps gave good performance for years, indicate that the appropriateness of the pump is quite high, but that it is important to inform the villagers properly.

Advantages

- Low cost, thus within the budget of an average villager.
- Local materials like bamboo are used, which are always readily available.
- Generally, the pumps can be maintained by the villagers themselves.
- The simple pumping mechanism is easy to understand.

Disadvantages

- Average life-time is five years.
- Maximal depth is eight metres.
- Only specific types and shapes of bamboo are suitable.
- It is not appropriate for heavy duty locations.
- Gives a bad smell during the first month if the bamboo has not been properly treated.

0305 - 0920/79/0116 - 0022 \$01.50/0 ●

Well Casings and Screens from Single Stalks of Bamboo, and a Manually Operated Slotter

by Stephen V. Allison, World Bank, Yaron M. Sternberg and Robert Knight, University of Maryland

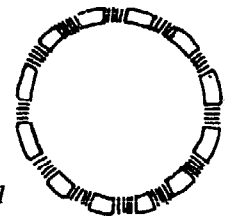


Fig. 1

Bamboo has been used in the construction of well screens to remove fine sand and silt in India and Bangladesh for several years. The most common design involves tying strips of bamboo onto a frame made of steel reinforcing rods, to form a basket-like structure of 100-500mm diameter, which is then tightly wound with coir rope to minimize sand entry to the wells.

For the construction of domestic water wells, however, and for small capacity irrigation wells, diameters as large as 100-500mm are unnecessary. Many thousands of domestic wells are in the 40-50mm size range, while hundreds of thousands of small irrigation wells have been installed with only 75mm casings. Bamboo naturally grows to these diameters and it was accordingly suggested in Assam, in January 1976, that if the slotting problem could be solved, single culms of bamboo should make satisfactory well screens for use in shallow alluvial aquifers.

A method for producing slotted bamboo using a single radial cutter powered by an electric motor has been described by Eaton.¹ Electricity is not available in many parts of the world where slotted bamboo culms can be used as filters. Thus, our efforts were directed towards developing a manually operated slotter. The unit was developed at the University of Maryland, Dept. of Civil Engineering, and is further described below.

Single Bamboo Casings and Screens

The manufacture of single bamboo well casings is an extremely simple process entailing only the removal of internodal blockages with either a sharp chisel or an auger on the end of a long steel rod. A variety of bamboo has to be selected which does not crack easily and it has to be well cured in advance of the slotting operation.

It was anticipated that the slots would close up after immersion in water and experiments were accordingly conducted to determine the extent of this effect. Culms slotted in both vertical and horizontal directions were submerged in water. Daily measurements thereafter confirmed that the walls swell as they become saturated, causing the slot opening to decrease. This effect follows an exponential decay curve, most of the ultimate decrease occurring in the first 24 hours and no measurable change occurring after four days. Slots cut in the horizontal direction decreased in width by an average of 40%, while those cut in a vertical direction decreased by only 30% of the original width. This is useful to the extent that it permits use of a thicker (and thus stronger) slot cutter than would be required to obtain a slot of given width, if no decrease followed submergence.

Analysis of typical aquifer materials revealed that with slot widths of 0.3mm, about 6% open area can be obtained in a culm of 65mm inside diameter (see Fig. 1), so that only about 1m of screen is required to admit each 1m³/hr of required discharge.

In the zone of water table fluctuation it is necessary to use either mild steel or plastic pipe to prevent rotting of the bamboo through successive wetting and drying cycles. The bamboo section of the well is thus placed in a permanently saturated environment and should last many years.

Manually Operated Slotter

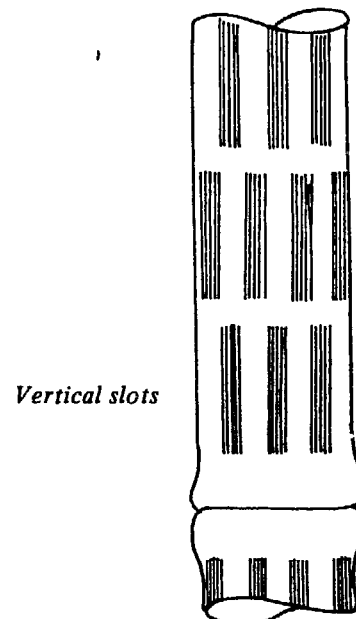
The idea of using bamboo culms for well screens created a need for a manually operated, reliable, simple, yet rugged machine for slotting the bamboo to a predetermined slot size.

The first requirement was to determine the best direction and speed for slotting. Culms were slotted at various speeds in both the vertical (along the fibres) and horizontal (across the fibres) axes. Slotting was found to be easier in the vertical direction, with an optimum speed of about 200rpm (65mm diameter radial blade).

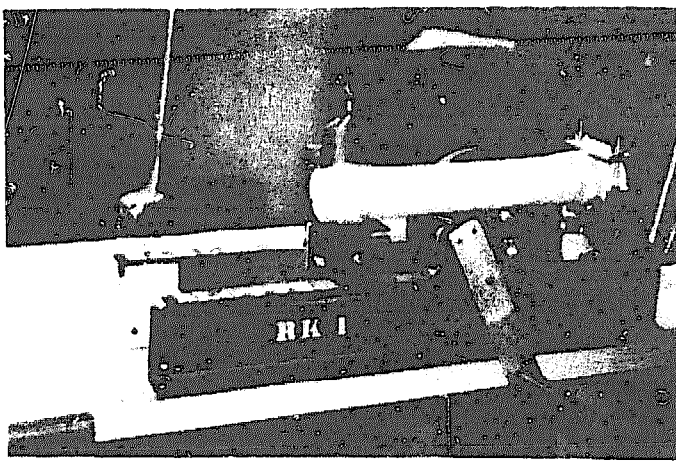
At higher speeds the culm tended to show burn marks, and at slower speeds the cutter snagged the fibres, particularly when attempting a horizontal slot. For the same number of slots between nodes, a culm with vertical slots appeared to be much stronger than the one with horizontal ones. Consequently, the results of the preliminary phase indicated that vertical slots obtained with a 0.5mm thick blade would be suitable as the final slot width after immersion in water would be approximately 0.3mm.

After determining the required cutter width, various "slotter" configurations were tested prior to the construction of the prototype shown.

The cutters are 65mm diameter and 0.5mm thick, mounted on a 1" arbor, with spacers measuring 2.0mm between each



Vertical slots



The bamboo clamped on the slotter.

cutter. Due to the spacing of the cutters and the curvature of the bamboo material, a maximum of five cutters was found to be most practical. (Such cutters can be purchased from, amongst other possible suppliers, the Sheffield Twist Drill and Steel Co.Ltd., Summerfield St., Sheffield S11 8HL, Yorkshire.)

As this was to be a manually operated machine performing a somewhat delicate task, i.e. feeding five 0.5mm thick cutters into a tough material such as bamboo, some rigidity had to be built into the frame.

The crucial points were the cutter arbor and the material clamping pivot. To combat possible dust conditions and provide easy alignment plus good rigidity, self aligning, permanently lubricated, pillow blocks were used for the two shafts. The pillow blocks in turn were bolted to a channel bar frame. This offered adequate strength and accuracy. A rigid frame constructed out of wood would also be suitable.

The components from the cutter arbor back to the cranking handle were less critical with respect to rigidity. The concern here was to design a mechanism with a compromise between mechanical advantage and velocity ratio which would not only be comfortable for the operator, but would also effectively cut the bamboo, i.e. provide a speed of approximately 200 rpm.

The gear train was made up on an 80 tooth driver, a thirty tooth driver and an idler of no specific number. The main reason for the idler was to allow turning the hand crank in the same direction of rotation as the cutters. It also allowed some flexibility in positioning component parts.

The handle has a 25cm throw which provides the operator with ample leverage. It is connected to the primary gear through a single speed freewheel bicycle chain sprocket.

The free-wheel has a dual purpose. Under no-load conditions the energy stored in the fly wheel tends to rotate the cutters at a speed which overrides normal cranking speeds; therefore, the operator is not obliged to keep up with the cutters. It also provides a worthwhile option. One can remove the handle, which is a simple procedure, and power the machine directly from the bicycle.



Slotting bamboo.

Cutter life is still undetermined. It can, however, be assumed favorable, as the original set performed well in many experimental test runs and is now being tested under field conditions.

Loading and operating the machine is a simple matter. The workpiece (bamboo) is placed in the V-blocks of the clamps, then securely tightened at the front (pivot) clamp. The rear spring loaded clamp is tightened as the material is fed down into the cutters.

When the workpiece is clamped in position and the cutters are in motion, slowly feed the spring loaded clamp downwards until the cutters make contact with the bamboo. The operator soon acquires a "feel" for the machine. The rate of workpiece feed and cutter rotation rely heavily on each other for an optimum condition. The operator, without drastic results, becomes aware if one of the factors is not correct and will adjust instinctively. When the cutters have reached full depth (approximately 10mm) the workpiece should be raised again to the starting position. Now the clamps are slackened and the workpiece moved either longitudinally or radially into a position for the next series of cuts. This is repeated until the desired amount of slotting is completed.

It should be noted that with a little practice the operator could discard the rear clamp and feeding mechanism and simply feed the bamboo by hand. This obviously speeds up the operation.

Where electricity is available, the slotter could, of course, be driven by a small electric motor.

Current Status

The prototype slotter was taken to Assam in mid-1976, since which time several wells using these bamboo screens have been installed. These are now being tested and observed. Further information is available from: *Mr H. Gogoi, Addl. Chief Engineer - Irrigation, Government of Assam, Gauhati.* ●

Chapter 7: Bamboo constructions

- 7.1. - Traditional joints of bamboo
by McClure p. 133
- 7.2. - How to calculate bamboo
by dr. Jules J.A. Janssen p. 136
- 7.3. - Bamboo Trusses
by dr. Jules J.A. Janssen p. 142

7.1.

This chapter starts with a summary of the traditional joints in bamboo, by McClure, his pages 16 and 17. The text, belonging to these drawings, is present in this book on pages 24 and 25.

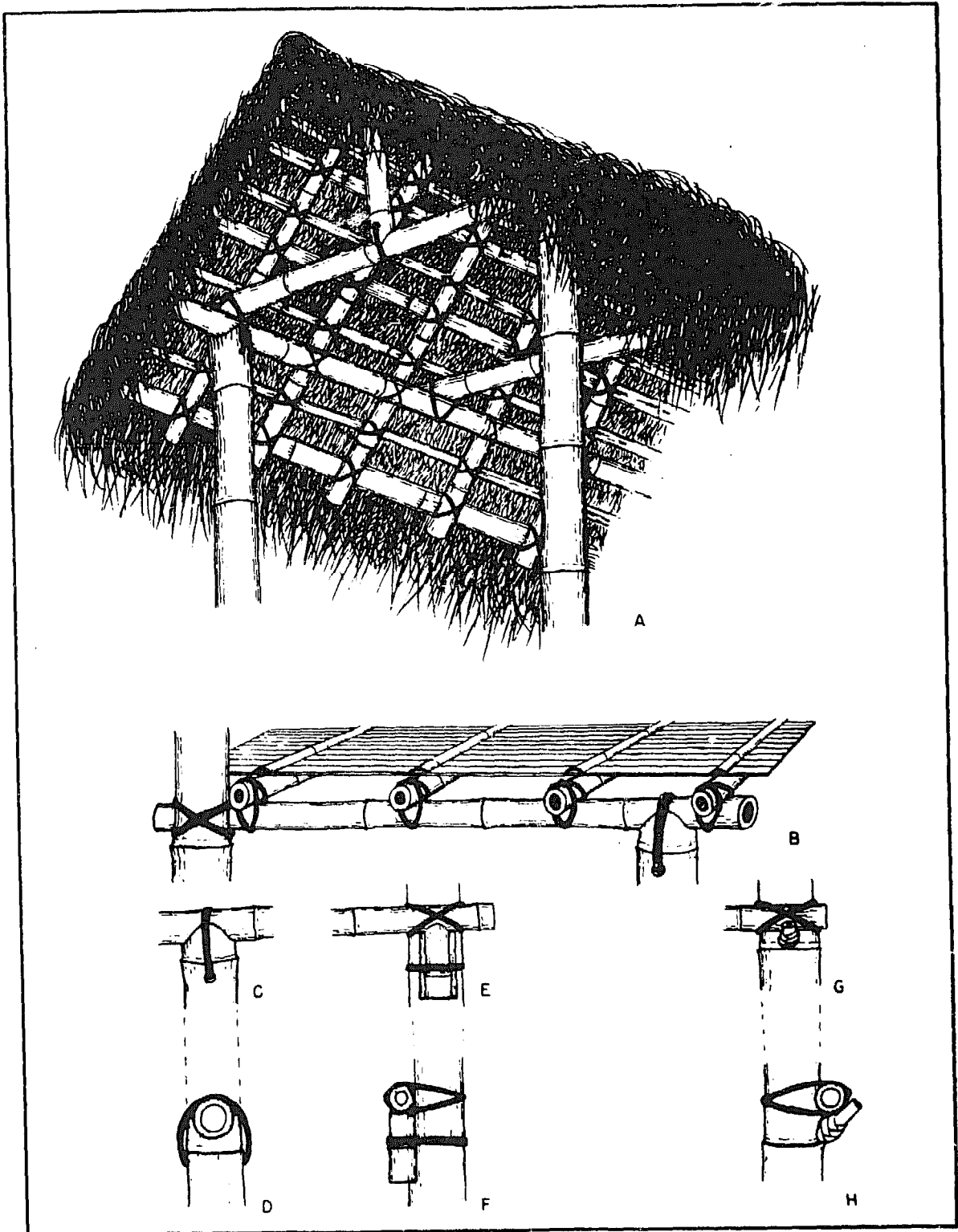


Figure 6.--Details of bamboo construction: A, fitting and binding culms at joints in roof and frame; B, fitting and securing bamboo boards of floor; C and D, saddle joint; E and F, use of inset block to support horizontal load-bearing elements; G and H, use of stump of branch at node of post to support horizontal load-bearing elements.

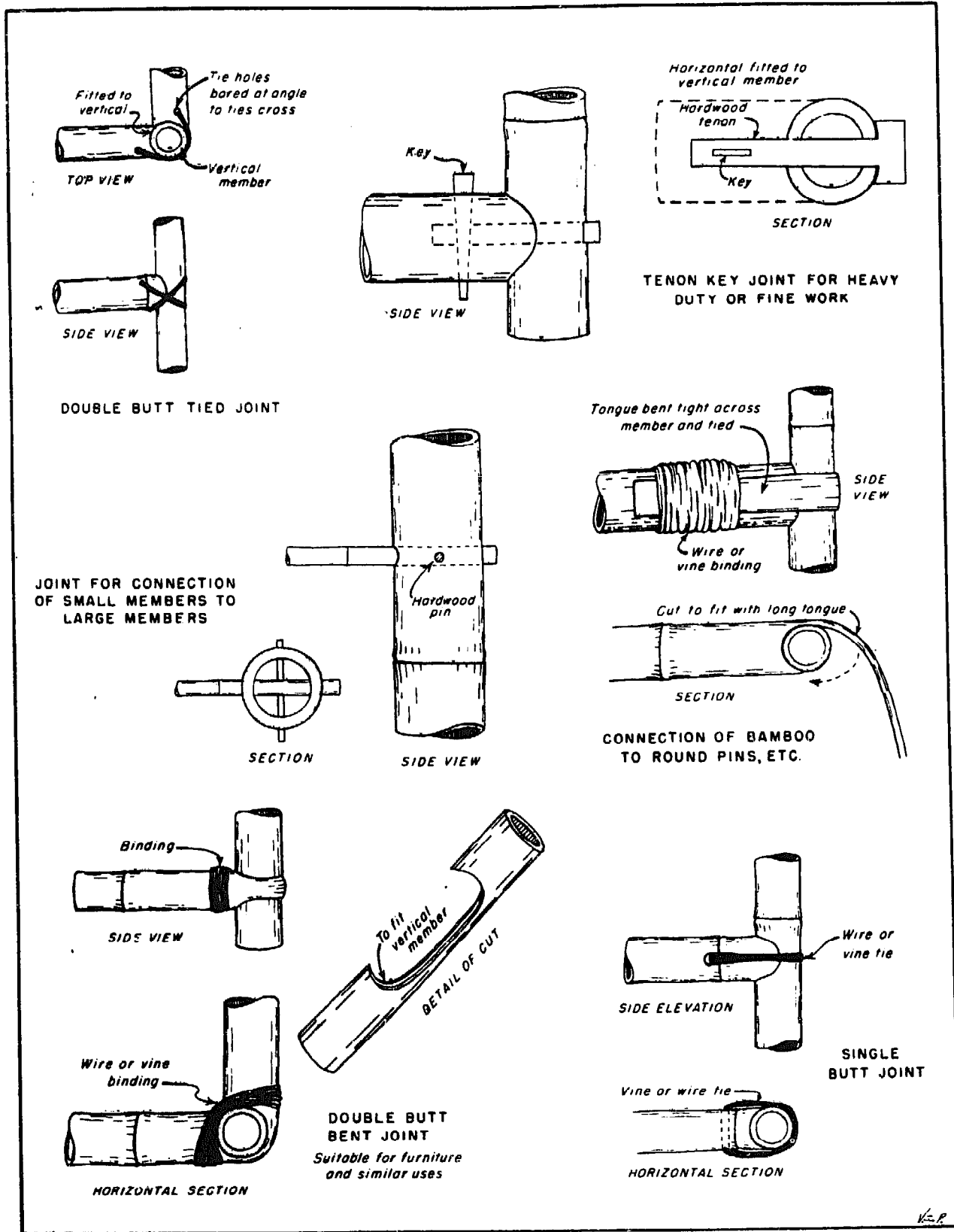


Figure 7.--Joints used in building with bamboo.

7.2.

How to calculate bamboo

by dr. Jules J.A. Janssen

In most cases a bamboo construction is built based on traditional methods. However, a recent research program by the author gives some possibility to calculate bamboo in a modern way. Some knowledge about mechanics is needed.

The research program mentioned ahead has shown a ratio between the mass per volume ρ in kg/m^3 and the allowable stresses in N/mm^2 , see table 1.

	compression (no buckling!)	bending	shear
dry bamboo (12 percent MC)	0.013	0.020	0.003
wet or green bamboo	0.011	0.015	-

Table 1. The ratio between the mass per volume ρ in kg/m^3 and the allowable stress in N/mm^2 .

Note: dry bamboo has a moisture content (MC) of 12 percent when in equilibrium with air with a relative humidity of 70 percent.

Example: if green bamboo has a mass per volume of 600 kg/m^3 , then the allowable stress in bending is $0.015 \cdot 600 = 9 \text{ N/mm}^2$.

These allowable stresses can be used in relationship with permanent load, e.g. the dead weight of floors, walls and roofs.

For the combination permanent load + live load (e.g. inhabitants furniture) 25 percent extra is allowable, and for the above plus wind 50 percent extra is allowable.

Example: the 9 N/mm^2 mentioned ahead becomes 11.25 or 13.50 N/mm^2 respectively.

However, the problem is to determine the mass per volume of the bamboo concerned. (On the contrary, this is much simpler than the determination of stresses at failure, so this method is really an improvement).

The mass per volume of bamboo is between 550 and 700 kg/m³. If the following method really is impossible, then calculate with 550 kg/m³. But this lower value is uneconomic, because the allowable stress might be higher.

The mass per volume can be determined as follows. At first the volume. Cut an internode (i.e. a piece of bamboo between two nodes) at right angles. Measure the sizes of this piece:

- the height H, in mm exactly,
- the outer diameter D, in mm exactly, at both ends twice, also four times in all, and calculate the mean value,
- the wall thickness w, in 0.1 mm exactly, also with micro-meter, at both ends four times each, also eight times in all, and calculate the mean.

Determine the weight G, in gram exactly, (try at a clinic, a grocer or at the post office).

Example, see sketch page 138.

$$H = 292 \text{ mm}$$

$$D = \frac{1}{4} (82 + 81 + 83 + 82) = 82 \text{ mm}$$

$$w = \frac{1}{8} (6.3 + 6.4 + 6.5 + 6.4 + 6.6 + 6.4 + 6.5 + 6.5) = 6.45 \text{ mm}$$

The volume is:

$$H \quad 3.14 \quad (D - w) \quad w \quad =$$

$$= 292 \quad 3.14 \quad (82 - 6.45) \quad 6.45 = 447000 \text{ mm}^3$$

The weight approves to be 272 grammes.

The mass per volume is:

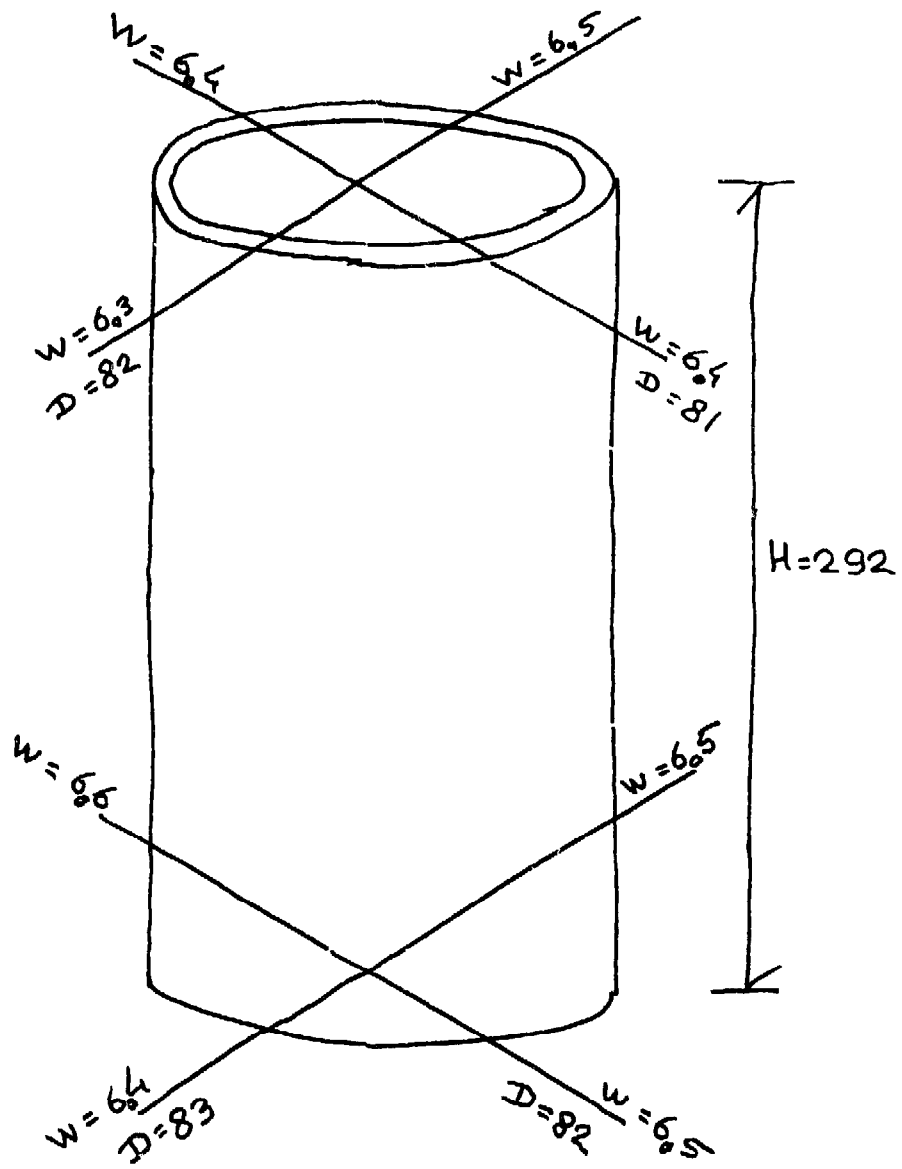
$$\frac{272 \text{ g}}{447000 \text{ mm}^3} = 608 \text{ kg/m}^3$$

The allowable stress for bending is (if this bamboo is dry)

$$0.020 \quad 608 = \quad 12.2 \text{ N/mm}^2$$

To calculate a bamboo in bending, we need to know the modulus of section W (i.e. the modulus of inertia divided by half the diameter), because bending stress σ = bending moment M divided by modulus of section W.

See table 2.



D	W						
	4	5	6	7	8	9	10
50	6000	7200	8000				
60		11000	12700	14000			
70		15400	17700	20000	21700		
80			24000	27000	29700	32200	
90				35100	38900	42200	45300
100				44400	49200	53800	58000

Table 2. The modulus of section W in mm³ as function of outer diameter D and wallthickness w, both in mm.

Example: we like to build a foot-bridge of 4 m free span. The available bamboos have a mean outside diameter of 90 mm.

We cannot measure the wallthickness in the middle of the length of the bamboo; at one end this thickness is 7.8 mm and at the other end 6.2, and as a result we assume as wall-thickness in the middle the mean of these two, i.e. 7.0 mm.

What is the allowable load on one bamboo culm?

$$\text{Allowable stress} = 1.25 \cdot 12.2 = 15.2 \text{ N/mm}^2$$

$$\text{From table 2: } W = 35100 \text{ mm}^2$$

$$M = \sigma W = 15.2 \cdot 35100 = 535000 \text{ Nmm} = 535 \text{ Nm}$$

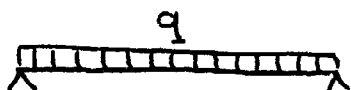
$$\text{Allowable load} = q = \frac{8M}{L^2} = \frac{8 \cdot 535}{4^2} = 267 \text{ N/m'}$$

Let us assume for the load on the bridge 1000 N/m (i.e. people, 750 N each, and walking at a distance of 0.75 m between them). We need 4 bamboos (4 is 1000 N/m divided by 267 N/m, and rounded off upwards), tightly joint together. The supports should be made at a node or as close to a node as possible.

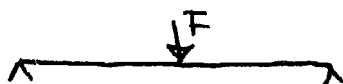
In most cases this calculation of the strength is enough.

Sometimes the deformation should be calculated as well.

Well known are the formulas:



$$f = \frac{5}{384} \frac{qL^4}{EI}$$



$$f = \frac{FL^3}{48 EI}$$

in which

f = deformation in mid-span, mm

q = equally divided load, N/mm

F = concentrated load, N

L = span, mm

E = Young's modulus, N/mm²

I = moment of inertia, mm⁴

For bamboo E = 20 000 N/mm², and the formulas can be simplified:


$$f = \frac{10 L^2 q}{D}$$


$$f = \frac{8 L^2 F}{D}$$

in which

f = deformation, mm

L = free span, meters

σ = actual stress, N/mm²

D = outer diameter, mm

In the case of our bridge the actual stress is:

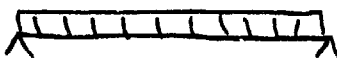
$$\sigma = \frac{M}{W} = \frac{q L^2}{8W} = \frac{1}{8} \frac{4000^2}{4 \cdot 35100} = 14.25 \text{ N/mm}^2$$

(Note: the 4 is the number of bamboos)

and the deformation is:

$$f = \frac{10 \cdot 4^2 \cdot 14.25}{90} = 25 \text{ mm.}$$

In practice a good guideline is to limit the deformation to $\frac{1}{300}$ of the span. To achieve this goal, the stress should be limited to


$$\sigma = \frac{D}{3L}$$


$$\sigma = \frac{D}{2.5L}$$

in which

σ = actual stress in N/mm²

D = outer diameter in mm

L = span, meters

This means for our bridge:

$$\sigma = \frac{90}{3 \cdot 4} = 7.50 \text{ N/mm}^2$$

allowable on each bamboo:

$$M = \sigma W = 7.50 \cdot 35100 = 263\,000 \text{ Nmm} = 263 \text{ Nm}$$

$$q = \frac{8M}{L^2} = \frac{8 \cdot 263}{16} = 132 \text{ N/m}$$

To bear 1000 N/m we need 7 bamboos tightly lashed together.

dr. Jules J.A. Janssen
Eindhoven University

Reference:

Bamboo in Building Structures,
thesis by the author, Eindhoven 1981.
235 pp. Price £ 5.50 plus airmail etc.

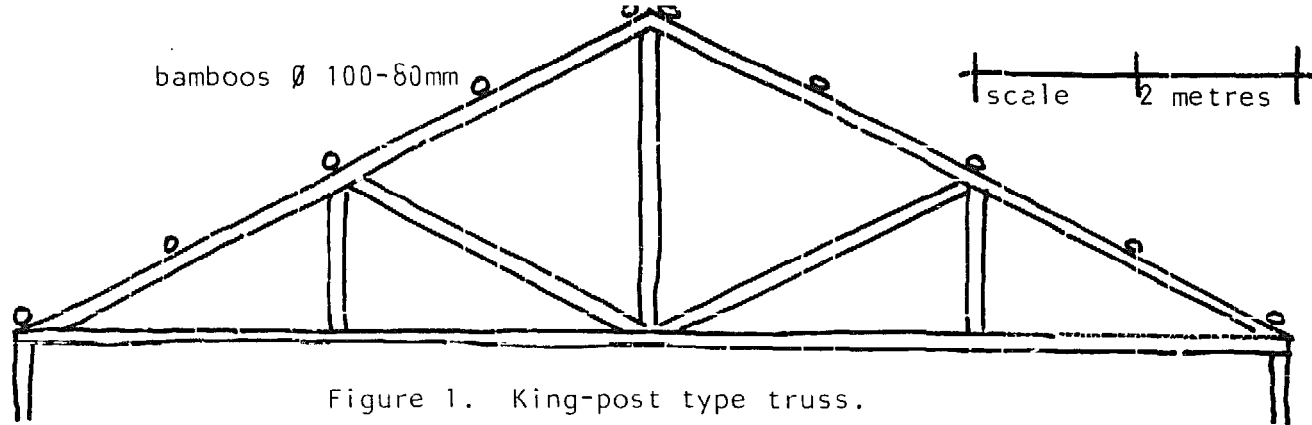


Figure 1. King-post type truss.

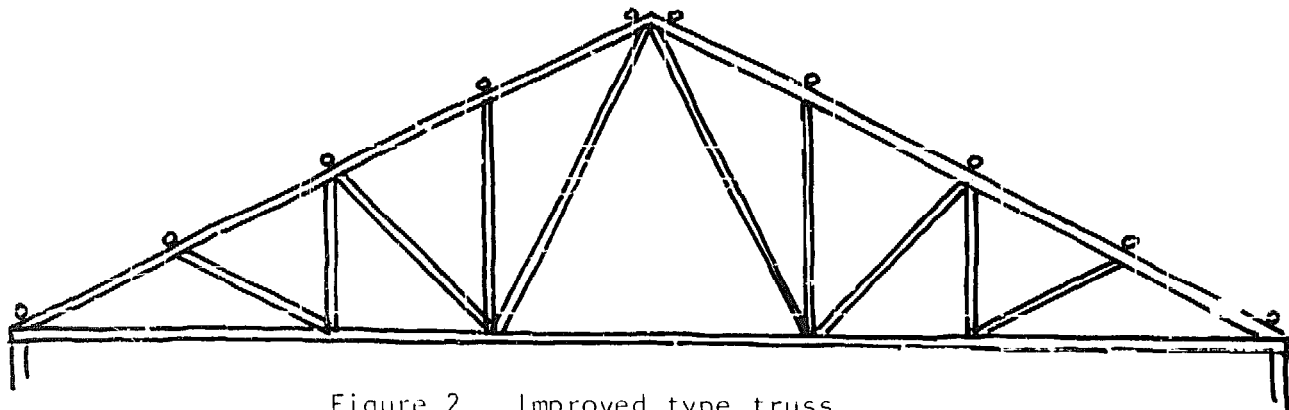
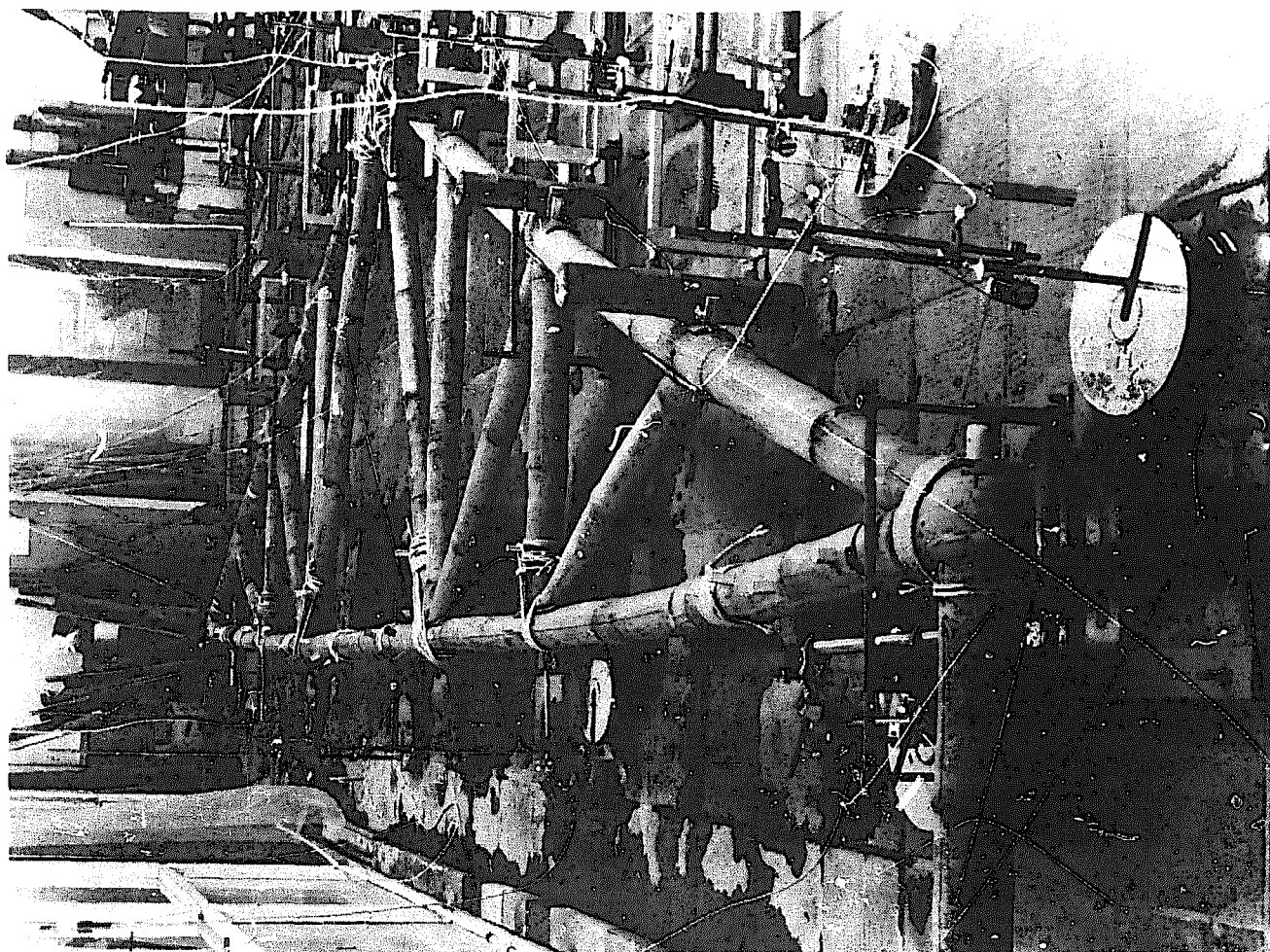


Figure 2. Improved type truss.



Picture 3. The truss, being tested.

7.3.

Bamboo Trusses by dr. Jules J.A. Janssen

Introduction

Bamboo trusses are constructions, being used to support roofs of buildings, or bridges. As to the roofs, roofs of houses are supported by that many columns or walls, that the support of such a roof is hardly a problem, but roofs of buildings like schools, medical centres, crop stores, with a free span of 8 m or more, need structural advice. With bamboo, such trusses can be built.

In the tradition of many regions, where bamboo is a familiar building material, such trusses do exist, but they have been built with too much bamboo and with an unknown safety. To improve this, a research program has been carried out at the Eindhoven University of Technology, dealing with trusses of a free span of 8 m, to support roofs of galvanised or fibre-cement corrugated sheets.

Figure 1 shows the well known king-post type truss, which has been tested in this program. However, an improved lay-out is shown in figure 2 and picture 3. The improvement means: stronger (25 per cent), and less deformation (12 per cent); on the contrary, more bamboo (11 per cent) is needed, and more joints (63 per cent) have to be made.

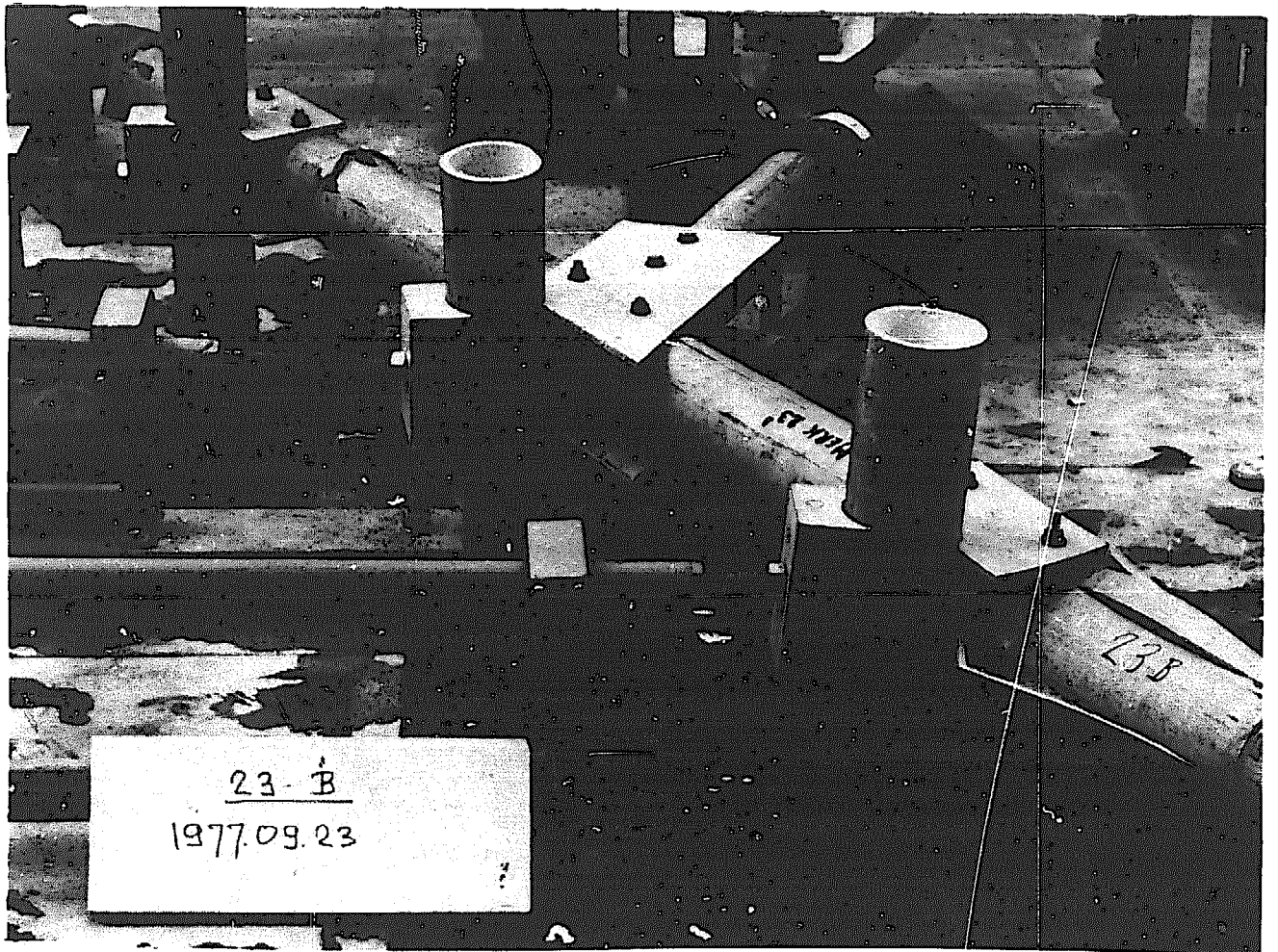
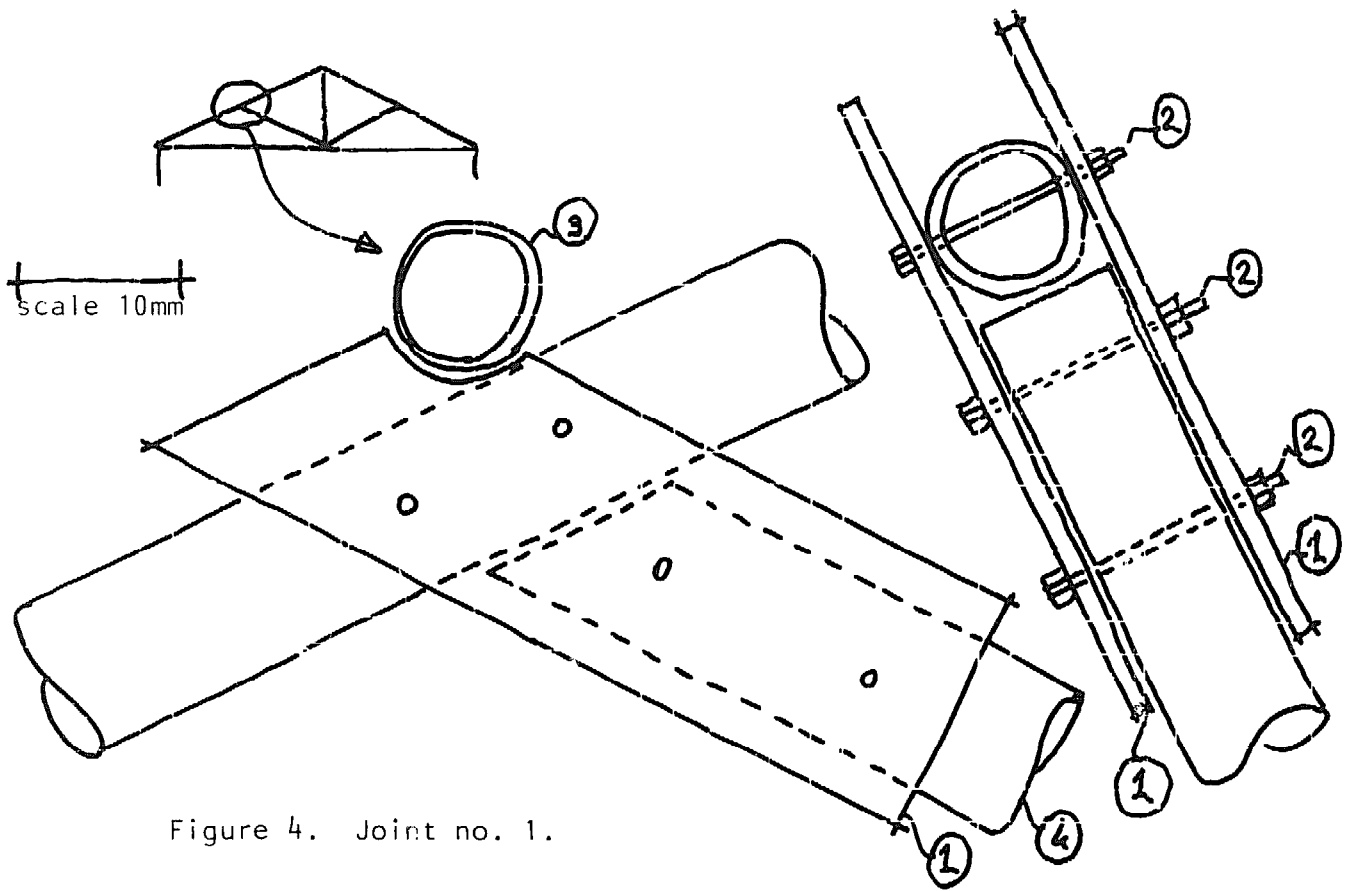
In the following pages some technical solutions how to make the joints will be discussed, as well as the mechanical behaviour of a truss as a whole, and finally problems dealing with purlins, stability, windload and earthquake.

A very important point, the durability of the bamboo, is not discussed in this chapter. The durability is a preliminary condition of first order.

The trusses, shown in figure 2 and picture 3, and properly detailed, can be loaded in practice with 4 kN on long term, and with 6 kN temporarily (e.g. people on top of the roof). (this 6 kN includes the 4 kN mentioned!) This means that they might support a roof with a free span of 8 m, and a distance of 2 m in the case of fibre-cement roof sheets, and 3 m in the case of galvanised roof sheets. Wind will be discussed further in this chapter.

The sizes of the bamboo are:

- upper and lower members: \varnothing 100 - 80 mm (outer and inner diameter)
- verticals and diagonals \varnothing 80 - 65 mm.



Picture 5. This joint, after failure.

For these trusses, four different types of joints have been designed and tested. A report on these joints is given now.

Joint 1

This joint is built with plywood (1) on both sides of the bamboo, and steel bolts (2) through and through.

This joint is the strongest and stiffest of all four joints described here. However, a disadvantage is the need of plywood and the steel bolts, which might have to be bought at high price.

In stead of the plywood, flattened oil drums could do as well, but this has to be tried yet.

This joint is shown in figure 4 and picture 5.

The joint is made with 10 mm plywood (1) on both sides, and four 8 mm steel bolts (2). The purlin (3) rests onto the plywood, but to resist wind suction the purlin has to be fastened with bolts or lashes, otherwise the roof will be lifted from the truss as soon as the wind velocity exceeds about 20 m/s, which is a moderate wind.

The joint is very strong; in practice in the diagonal (4) an axial compression force of 2.4 kN on long term is allowable, and of 3.6 kN for short term loading.

It is important to place the joint in bamboo structures in such a way, that a joint is made at a node, or as near to a node as by any means possible.

Picture 5 shows this joint, being tested with hydraulic jacks.

The joint is laid down onto the floor to facilitate the test only.

The failure can be seen as well:

An advantage of this joint is, that prefabrication of series is possible. In the other joints, described on the next pages, the bamboos have to fit precisely. Due to the fact that bamboo is not straight at all, this precise work might become a headache. But in this case a precise fitting is not necessary, because the plywood does the job.

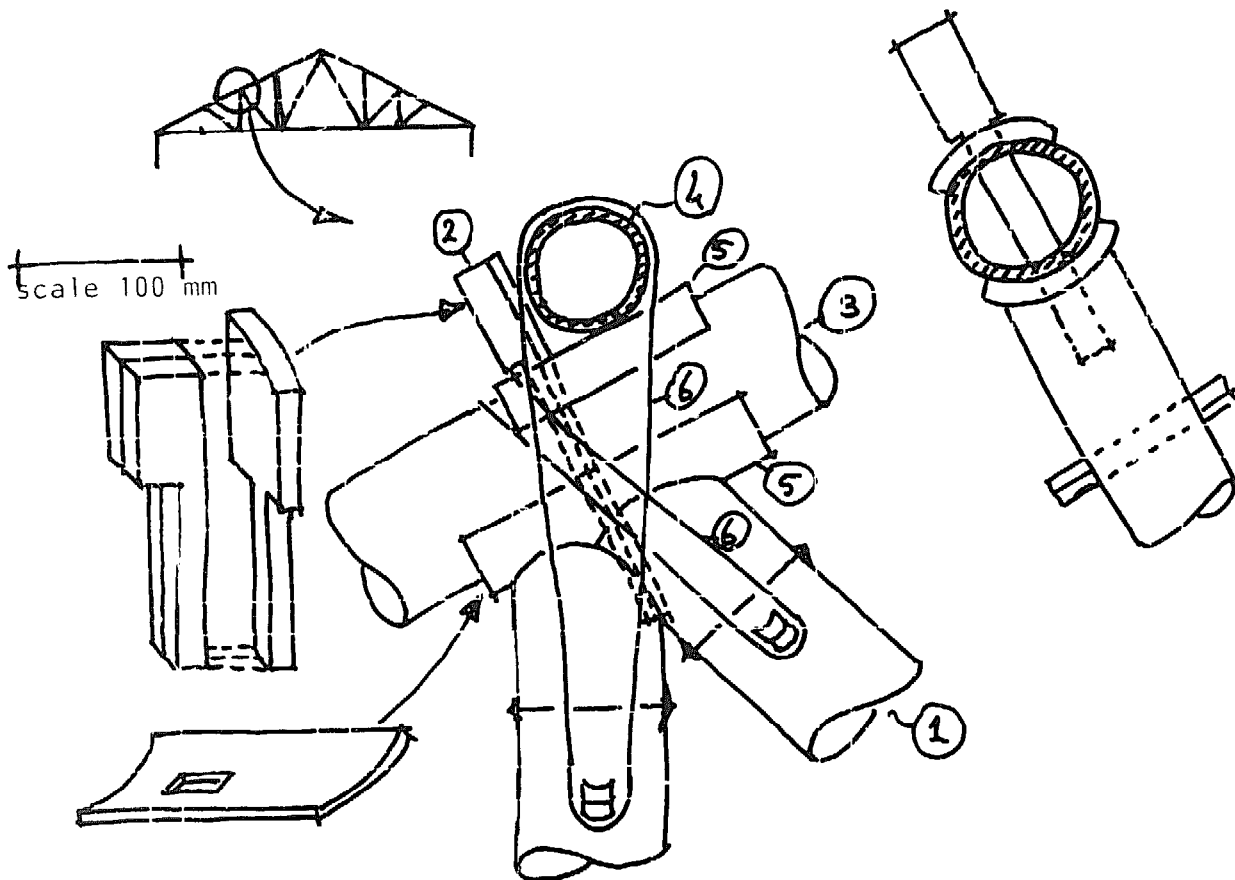
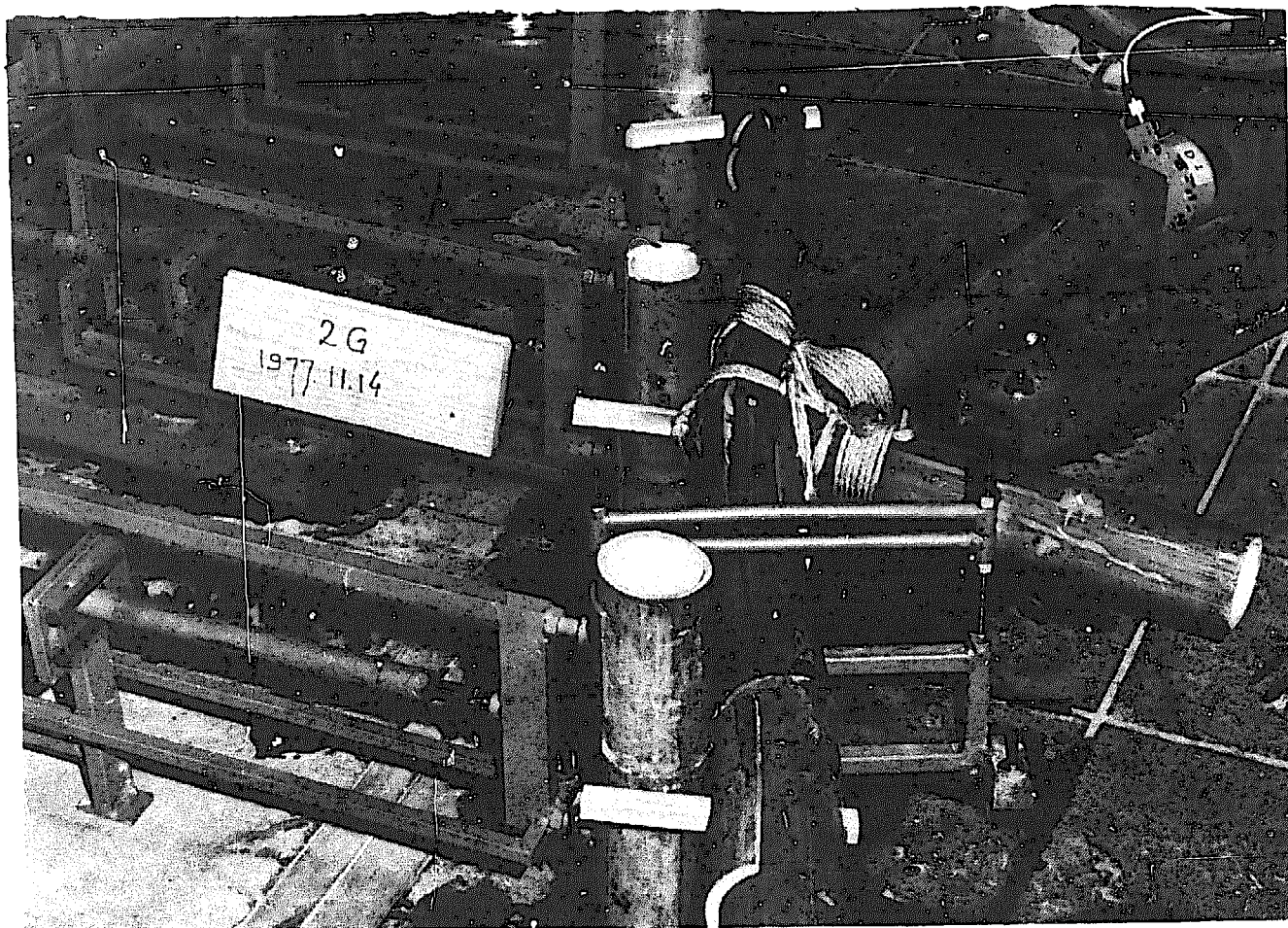


Figure 6. Joint 2.



Picture 7. Joint 2, in test, after failure.

Joint 2

In this joint the diagonal (1) rests against pins (2) through the upper member (3), see figure 6.

The pins (2) have two functions: they support the purlin (4) and they support the diagonal. A split bamboo as an intermediate layer (5) on both sides of the upper member prevents this upper member from being penetrated by the purlin or the diagonal. This simple detail improves the strength considerably.

The form of these pins provides a better support for the purlin, and prevents the pins from falling down onto the floor.

To be kept in place, the intermediate layers fit around the pins.

In the diagonal an axial compression force of 1.5 kN can be allowed permanently, and 2.25 kN temporarily.

The lashings (6) can be made e.g. with sisal rope 5 mm; they are drawn as a single line, but each line symbolises three ropes.

The reason for this rope is wind suction: the compression force in the diagonal changes into a tensile force!

Picture 7 shows this joint after failure in the test. In practice the purlins have to be lashed!

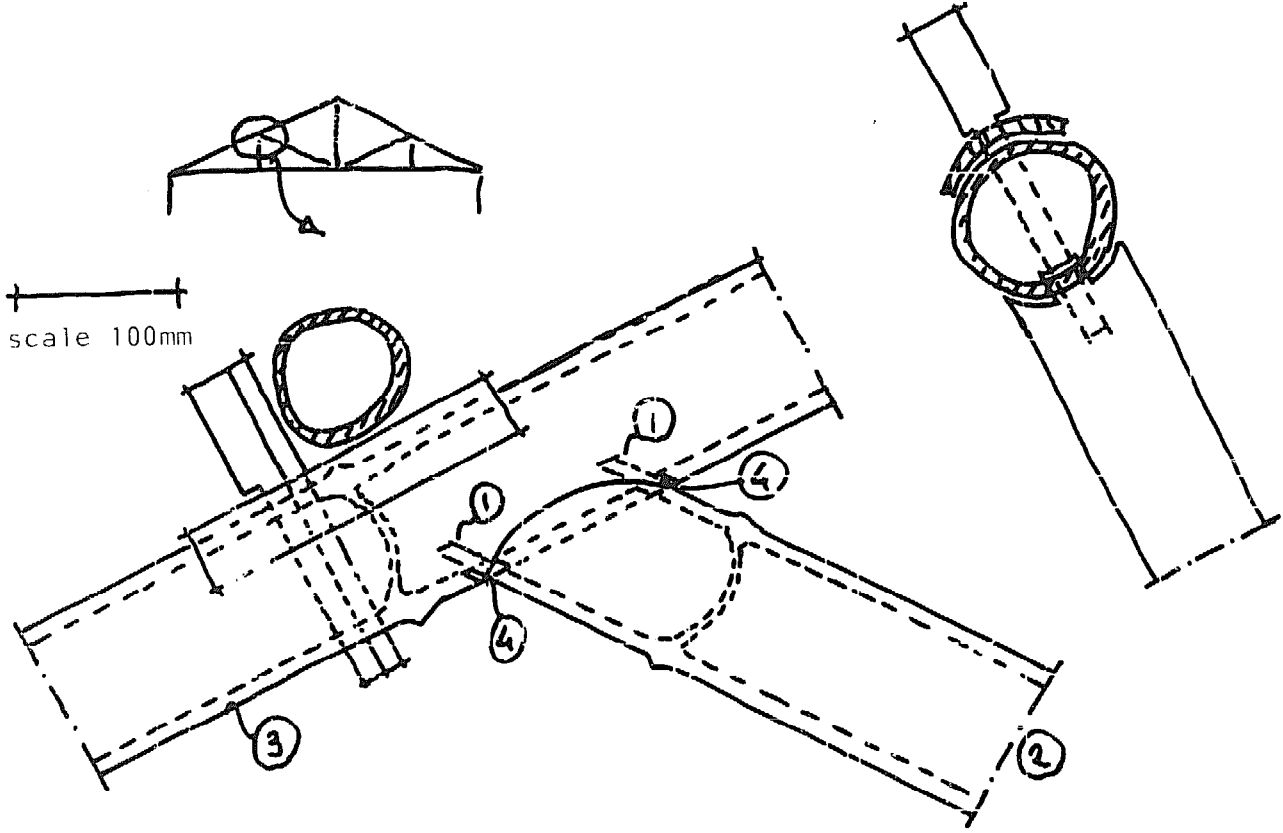
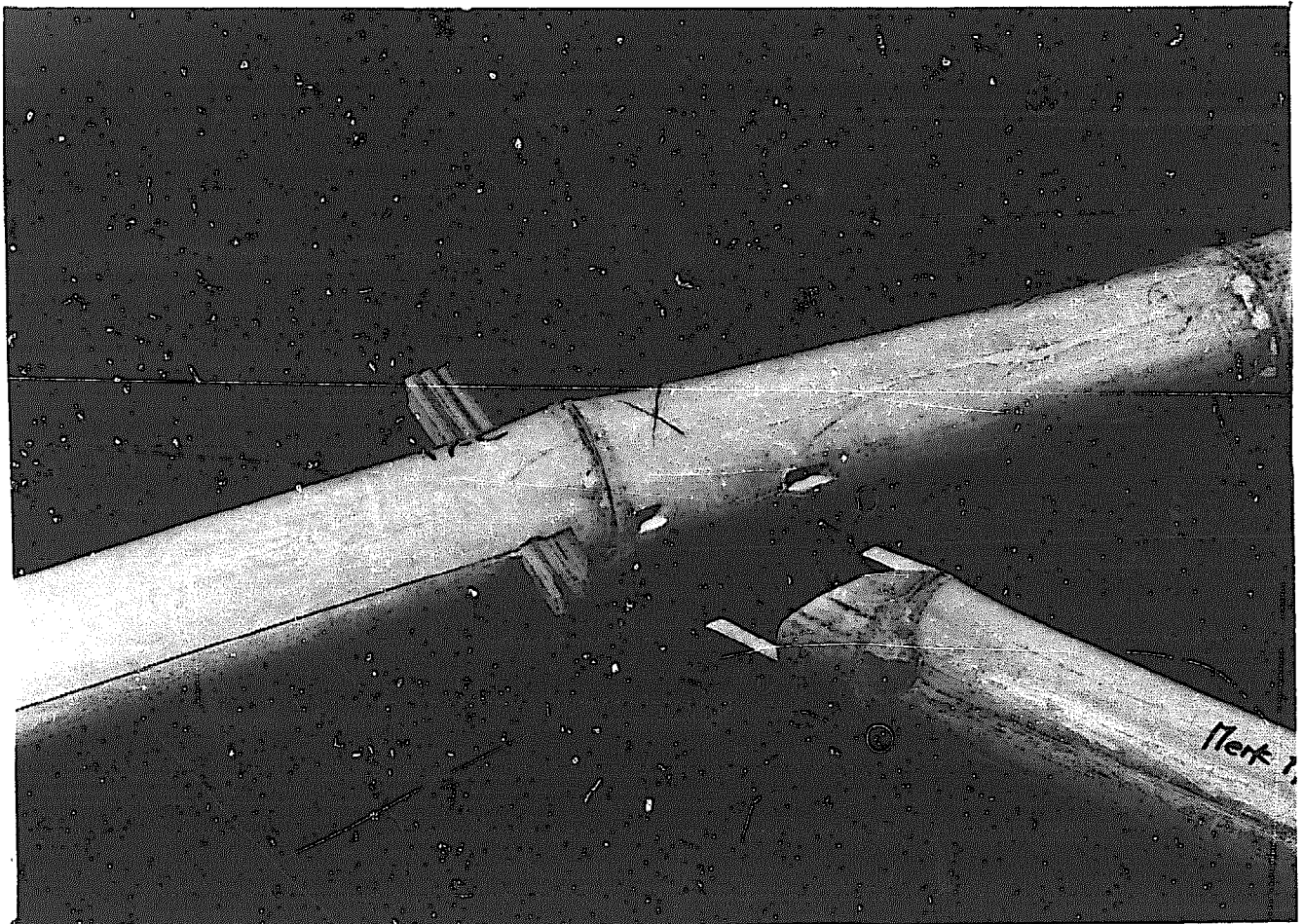


Figure 8. Joint 3.



Picture 9. Joint 3; vertical and lashings left away.

Joint 3

Joint 3 is based on two "horns" (1) at the end of the diagonal (2), entering the upper member (3) into two holes (4). The joint is lashed with rope. Horns like these are a very traditional method to join bamboos, but reports on strength tests were unheard of. An allowable compression force in the diagonal is 1.1 kN permanently and 1.7 kN temporarily. A disadvantage of this joint is, that the diagonal has to fit on both ends exactly between upper and lower member of the truss. This requests craftsmanship and time, and prevents prefabrication.

A node in the upper and lower member should be as close as possible to the joint.

The vertical fits simply in between, and is lashed. Horns are not necessary because the forces in a vertical are smaller than in a diagonal.

Picture 9 shows this joint as an exploded view, and all lashes and the vertical left away.

scale 100mm

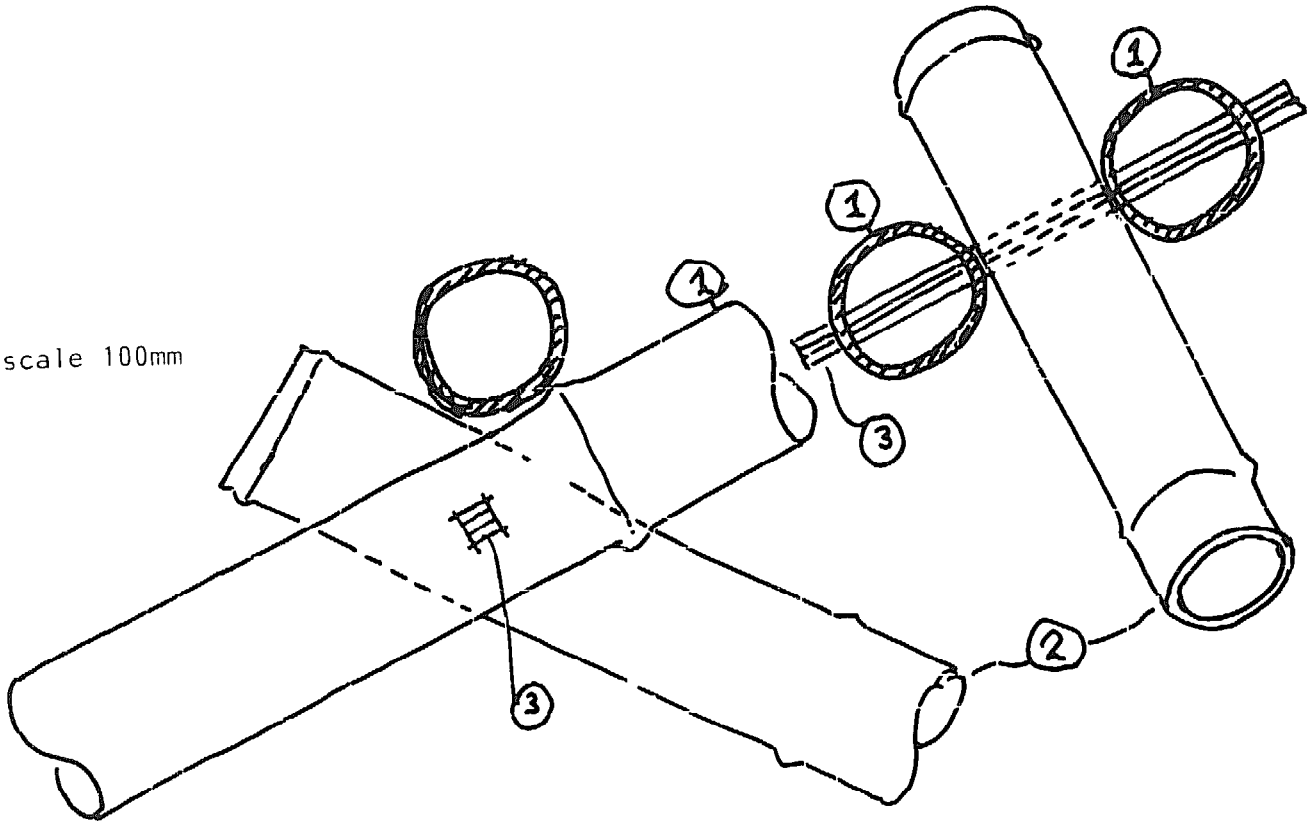
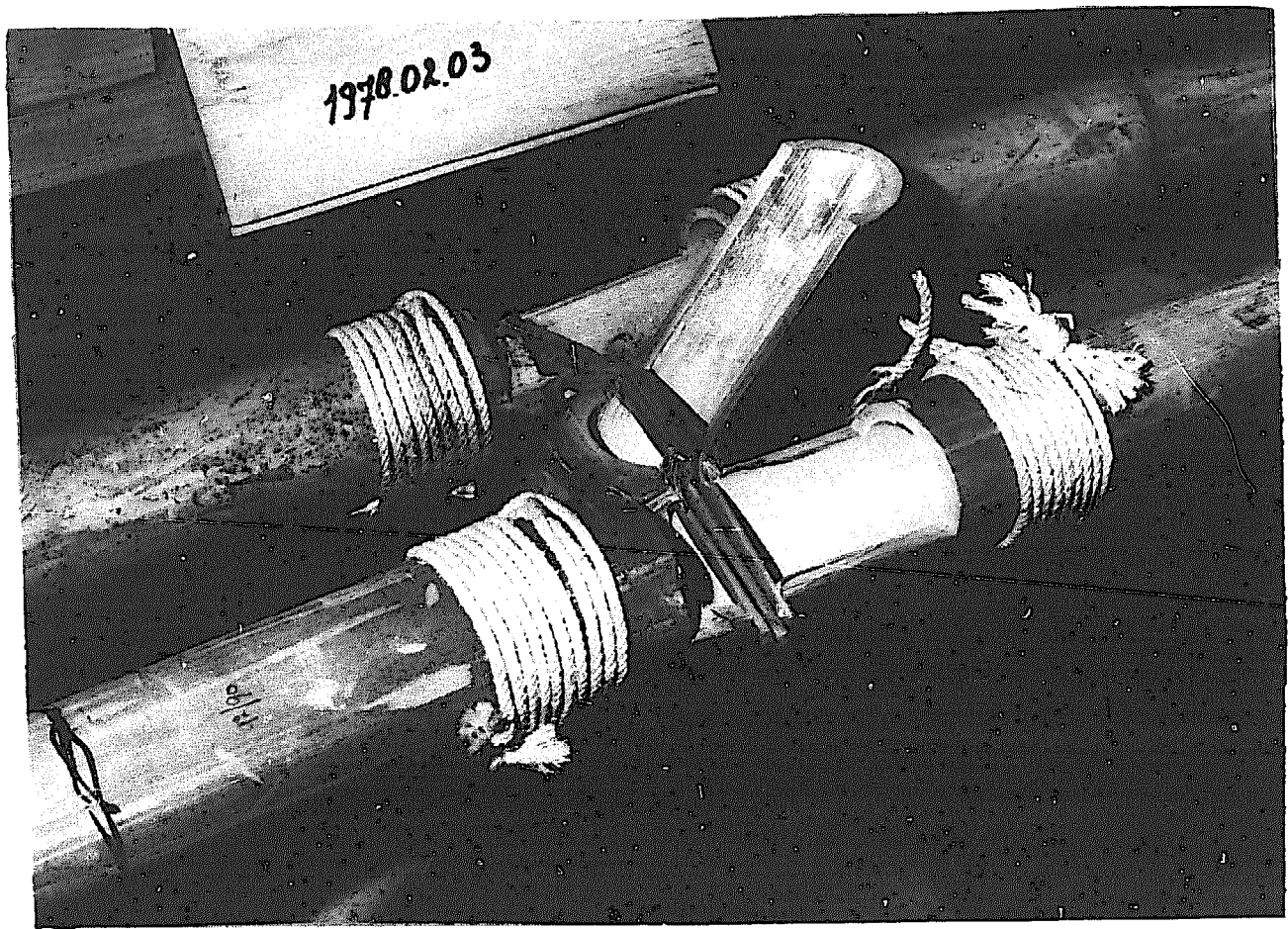


Figure 10. Joint 4.



Picture 11. Joint 4, opened after failure.

Joint 4

Joint 4 is based on the principle of a truss with double upper and lower members (1) and single verticals and diagonals (2), fitting in between these.

At each joint a hole is drilled through all three bamboos, and this hole is made square with a rasp, to allow the bamboo pins (3) to fit into this hole. Prefabrication is very well possible. This joint can be made also with a steel bolt instead of a bamboo pin; with a steel bolt this joint has a long history in bridges, as long ago as the end of the past century.

The allowable axial compression force in the diagonal is 1.6 kN permanently and 2.4 kN temporarily.

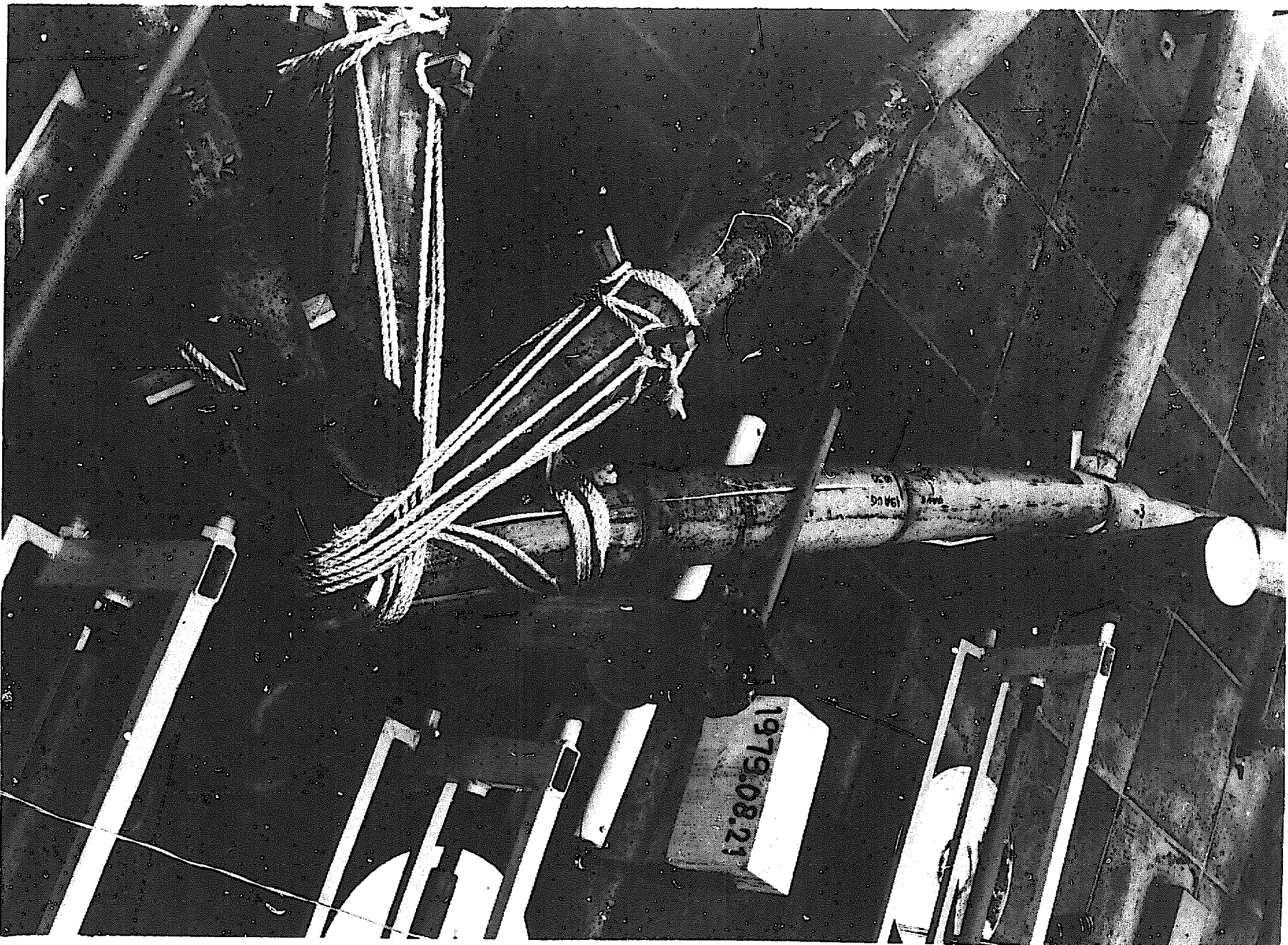
The purlin should be lashed, and the double members should be kept together with lashes as well.

Picture 11 shows this joint, opened after failure. The failure in the bamboo pin looks like yielding in steel!

This picture shows also a circular rope (4) round the upper members.

The purpose of this rope was a kind of prestressing, to avoid splitting of these bamboos. This increases the strength slightly.

A node near the joint does the job better. The three pins (3) are each 7 x 10 mm.



Picture 12. Failure of an upper member .

Trusses, short term behaviour

Trusses, built with joint no. 2, have been tested on full scale, with a free span of 8 m, see figure 2 and picture 3. The short-term strength has been determined as about 29 kN. This load has been brought onto the purlins by a system of hydraulic jacks.

Failure occurred in the upper member, due to stresses caused by a bending moment of about 1100 Nm and an axial compression force of about 11 kN. A bamboo with an outside diameter of 100 mm (as in our case) should be considered as insufficient; in practice a bigger one, e.g. 120 mm, should be taken for the upper members.

A next improvement is a greater stiffness for all joints. Due to the deformation in all joints, the curvature of the truss and consequently of the upper member is considerable, and this causes failure. Better stiffness has to be studied as yet.

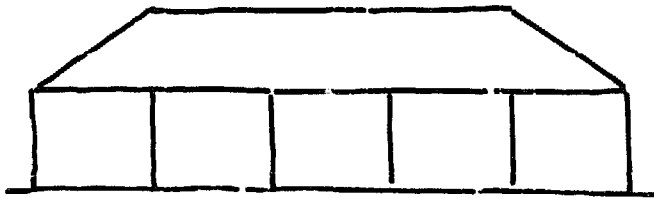
In our case the immediate deformation of the trusses in mid-span has been determined as about 40 mm (i.e. 1/200 of the span of 8 m) under a load of 18 kN; in practice, this truss will be loaded with 4 kN, and an immediate deformation of 10 mm should be expected.

On the long term, this deformation will increase up to 2.5 times this immediate deformation. Consequently, in practice a deformation of 25 mm could be expected. This increasing deformation is due to the joints, not to the material bamboo.

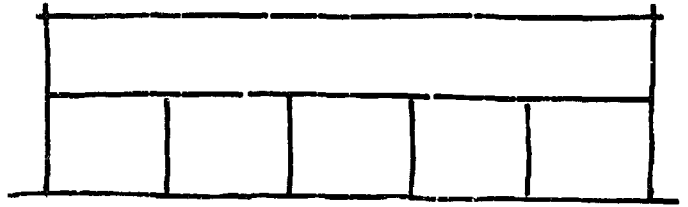
Failure means splitting of the bamboo, see picture 12. However, when the load has been removed, the bamboo will regain its original form. This means in practice, that a bamboo structure will survive an earthquake or a storm, and that damage can be repaired temporarily by lashing the split bamboo with circular lashes around it.

The building can stay in use, until a definitive repair can be carried out by replacing the damaged bamboos.

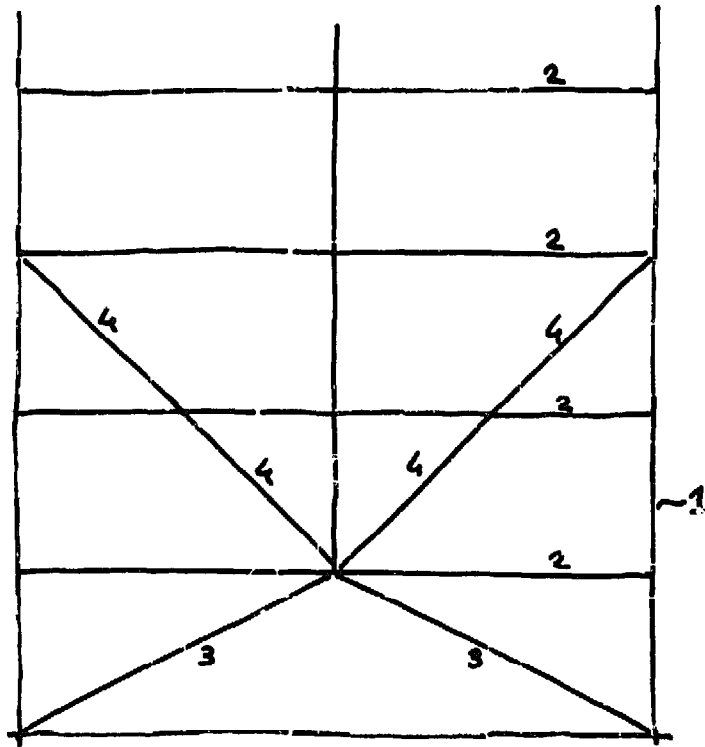
13



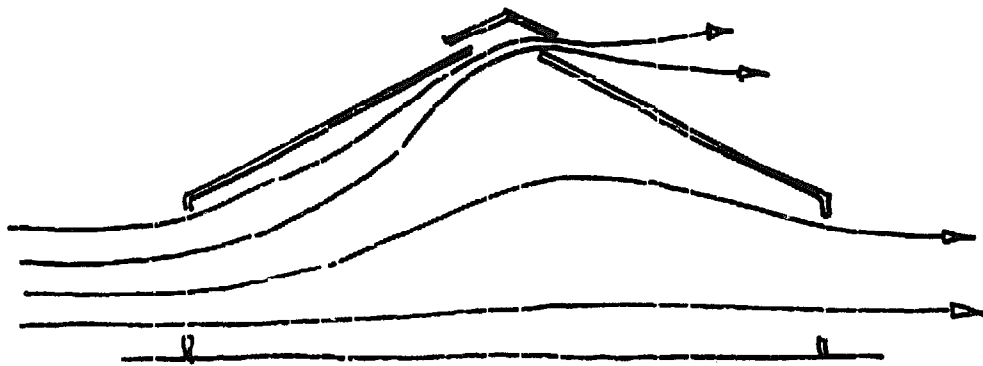
14



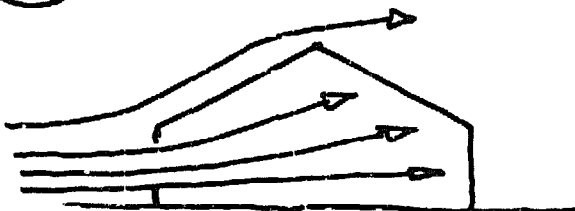
15



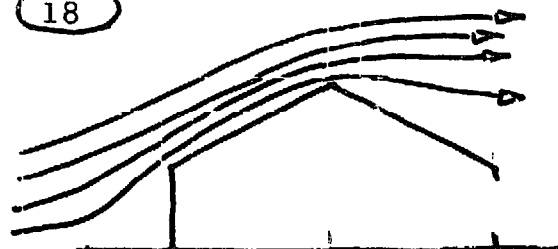
16



17



18



Stability, wind, purlins

Wind load is a problem, mainly due to the suction: this is an upward force, by which the roof can be removed from the building.

The dead load of the roof might prevent this as long as the dead load exceeds the suction. Galvanised corrugated roof sheets are light weight sheets, and a wind velocity as low as 20 m/s is sufficient for an equilibrium between dead load and wind suction.

With fibre-cement roof sheets, this break-even point is 27 m/s.

In practice higher wind speeds will occur, but with proper lashings and details the bamboo trusses described before can do up to 38 m/s wind velocity. (see next page)

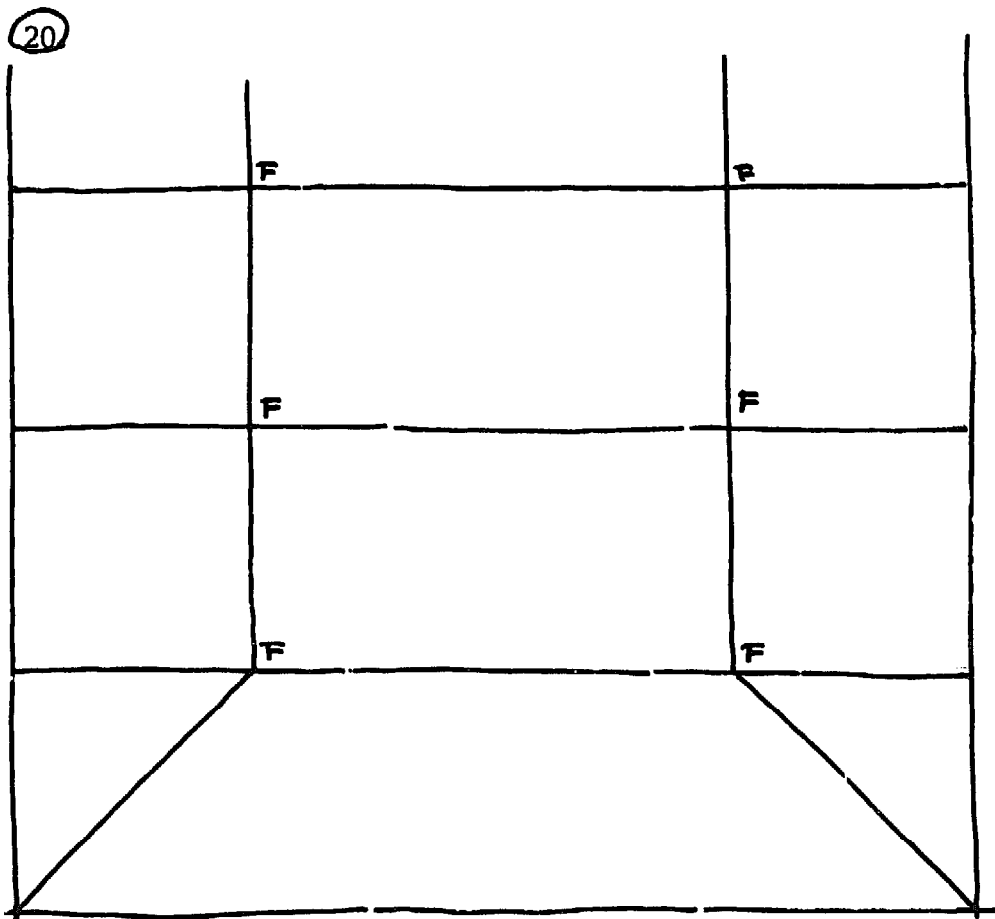
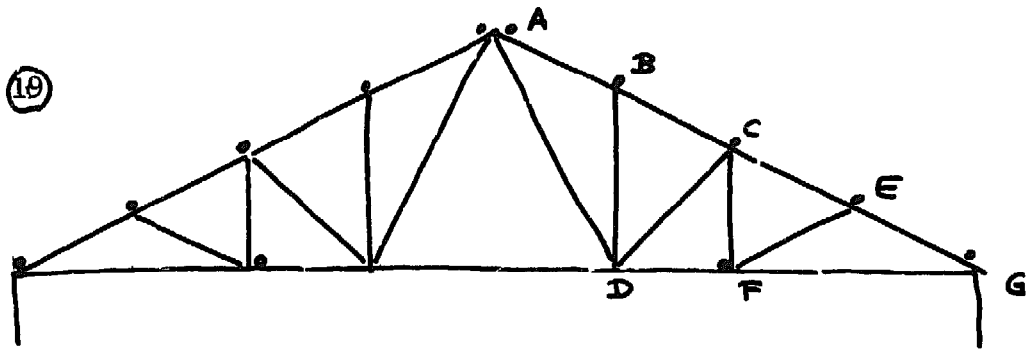
Next, the danger of wind can be minimized as follows.

- Figure 13 shows a better form for the roof than figure 14.
- Figure 15 shows a plan of the roof, with stabilising braces:
 - 1 = building
 - 2 = truss
 - 3 = hip
 - 4 = brace in roof (between or under the purlins)
- Figure 16 shows a ridge ventilator, to control both high temperature under the roof and wind suction.
- Figure 17 shows the best way to blow up any building, by large openings towards the wind. On the contrary, figure 18 shows how to achieve a suction inside the building by creating an opening in an area away from the windward wall. If this is done carefully during a storm, taking into account changing wind directions, occupants can deliberately control the internal pressure, and save the building.

As to the purlins, their strength is determined by the load of a man, sitting on a purlin during the erection of the building. This means:

distance of trusses	outside diameter	wall thickness
2 m	80 mm	7 mm
3 m	90 mm	8 mm

All purlins have to be lashed tightly to the trusses; wind suction is a tremendous upward force!



High wind

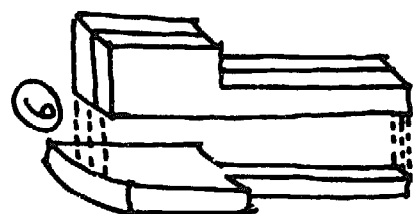
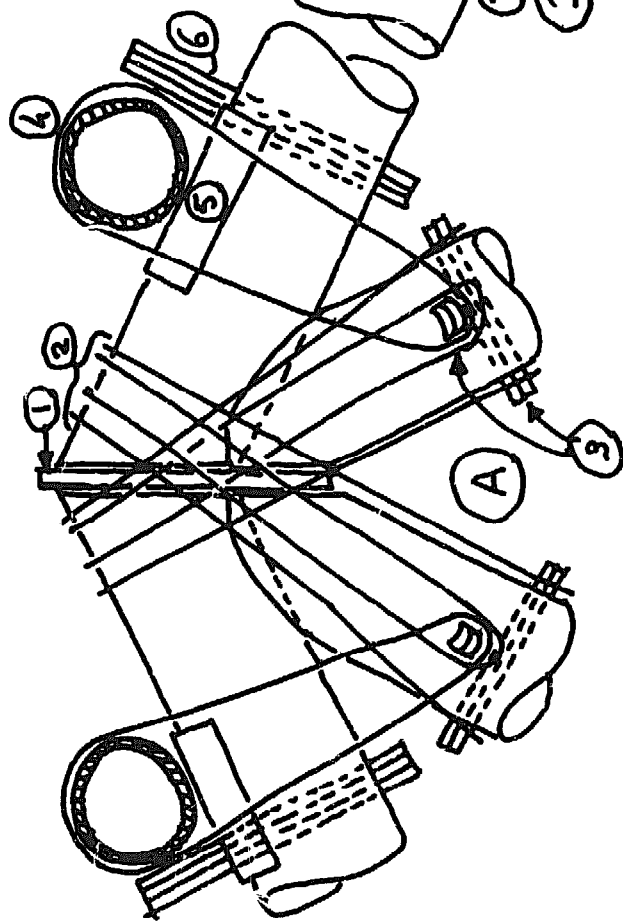
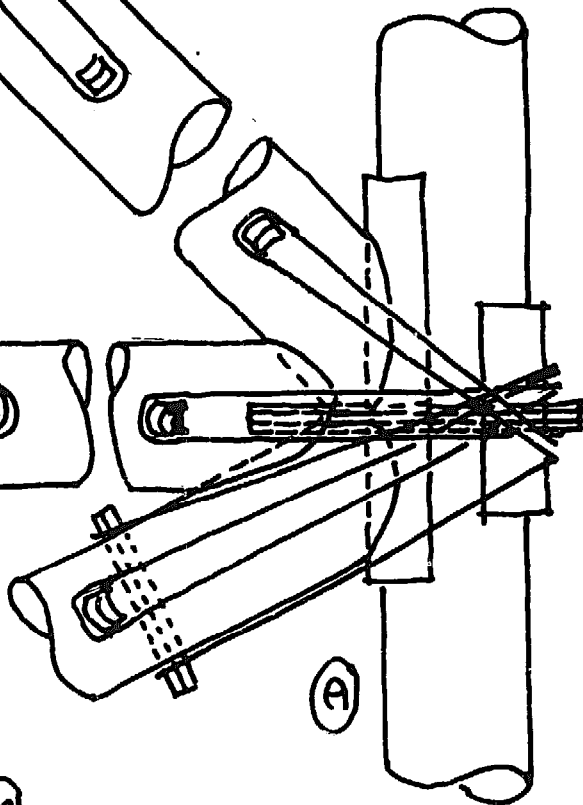
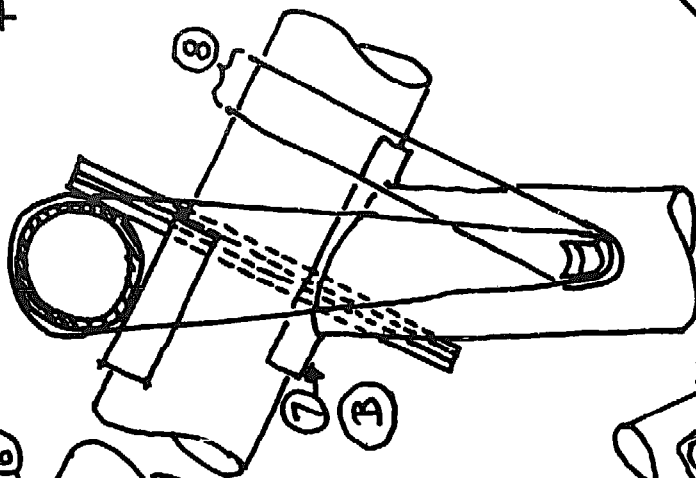
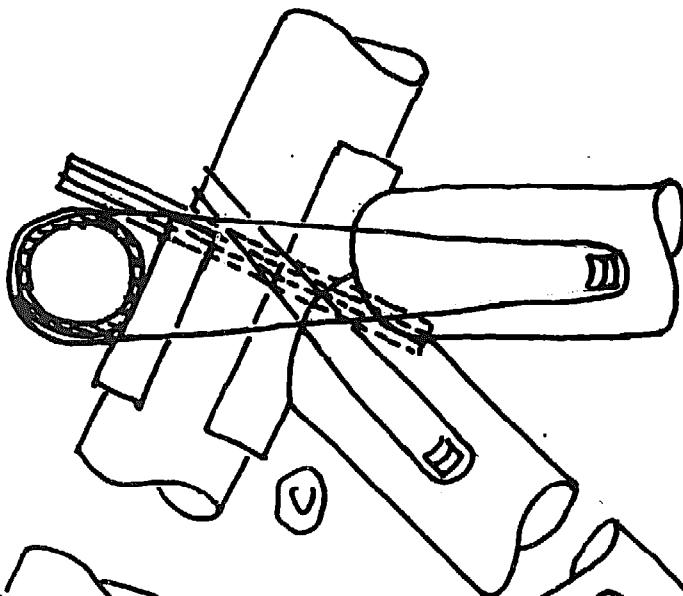
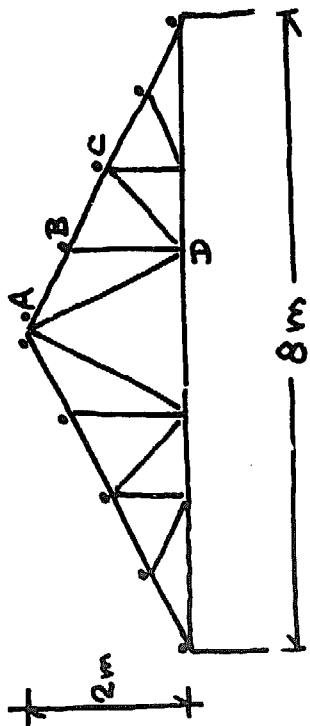
If the wind velocity might be higher than 20 m/s (galvanised roofsheets) or 27 m/s (fibre cement roofsheets) the following precautions have to be added.

See fig. 19 and 20.

- Fasten diagonal C D with rope similarly as A D
- Give a support in horizontal direction to point F, as shown in top-view in fig. 19.
- Fasten A and G with rope similarly as A D, and fasten the column G similarly to the foundation.

With these precautions the next possibilities become available:

roof sheet	distance between trusses	wind pressure	wind velocity
fibre cement	3 m	825 N/m ²	38 m/s
galvanised	3 m	490	30
galvanised	2 m	660	35



100 mm.

Details

for a truss with joint no. 2.

Bamboos upper member \emptyset 100 - 80 mm

(i.e. outer and inner diameter resp.), other members \emptyset 80 - 65 mm.

Detail A

1. Intermediate layer of flattened bamboo, between the two ends of the bamboo upper-members.
2. Sisalrope or equal, 5 mm, shown four lines but each lines represents three ropes, total twelve.
This is due to the high tension force in A D.
3. Pins to hold the ropes of no. 2, cross section 15 x 15 mm.
4. Purlin, fastened with two sisalropes 5 mm at a pin of no. 3, to hold down the roof in case of wind suction.
5. Intermediate layer as shown in detail.
6. Pins to support the purlin, see detail.

At the top they are broader, for a better support to the purlin, and to prevent them from falling out of the hole.

Detail B similar as A only:

7. Intermediate layer, see detail
8. Sisalrope to keep the truss together during erection, and against windsuction.

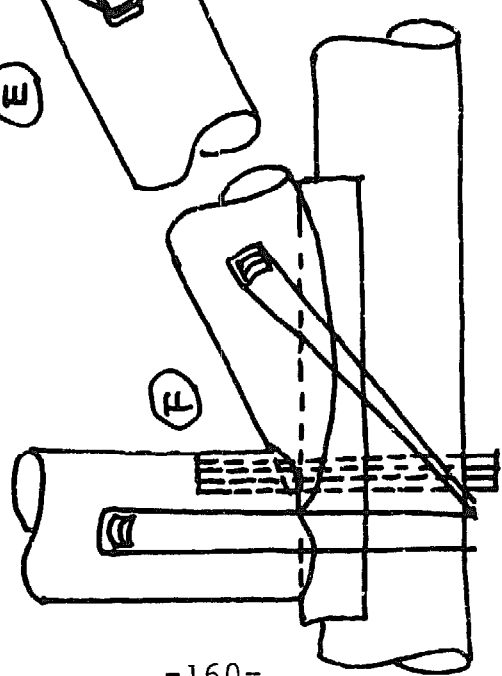
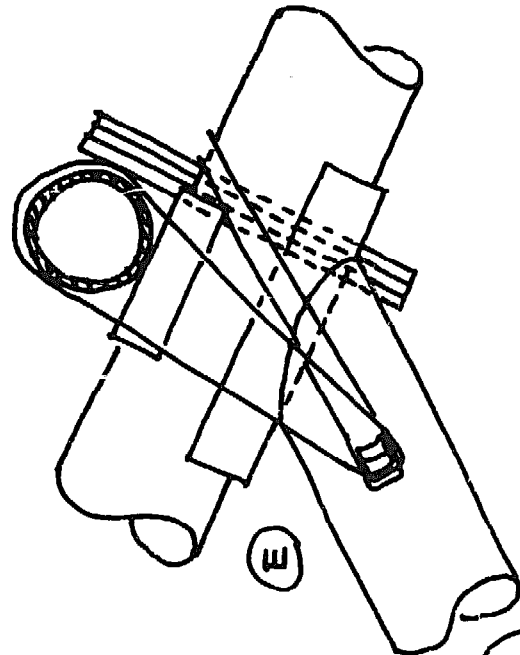
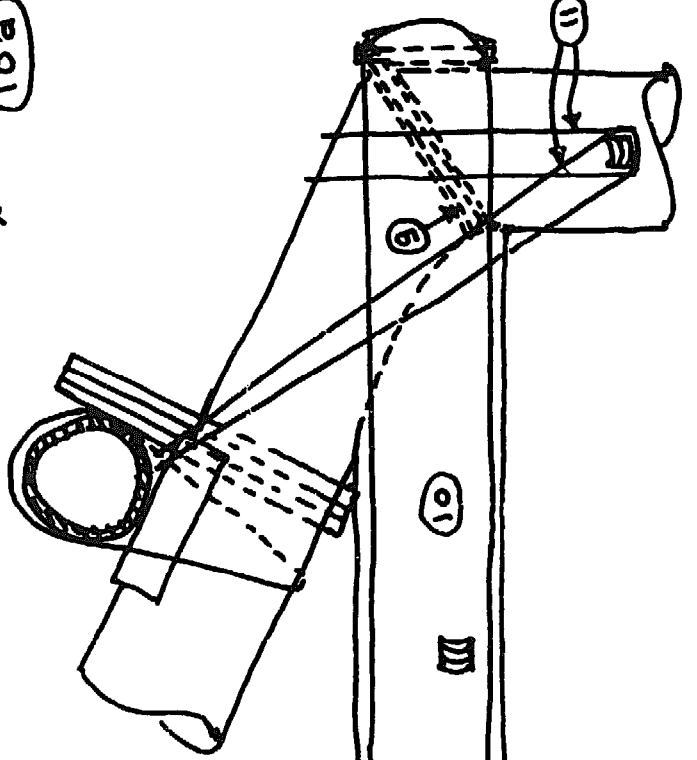
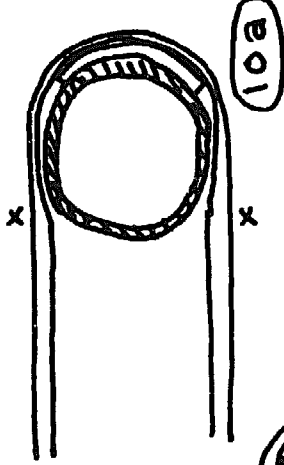
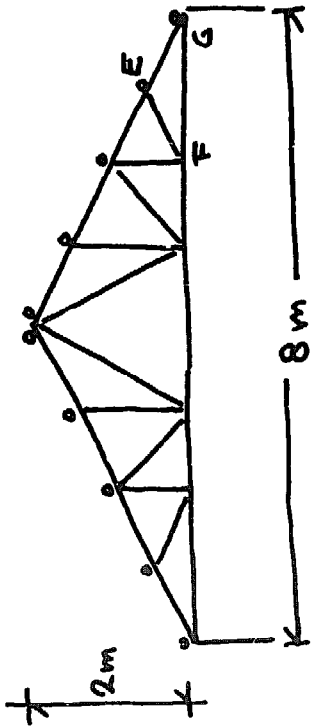
N.B. The vertical B D rests against the pins no. 6.

Detail C as A and B

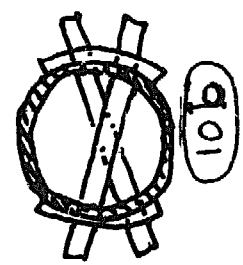
Detail D

Ropes of B D and C D see 8, and ropes of A D see 2.

Diagonal C D see above (high wind)



G



100 mm

Details E and F, nothing new.

Detail G

This support is difficult and important.

9. An intermediate layer between upper member and column, as in 1.
10. Tension joint between lower member and column, a kind of hairpin. Detail 10 a shows a top view: between the two crosses only the outer half of the bamboo is taken, because the inner half is weaker and bending of the full thickness is difficult. Detail 10 b gives a cross-section.
11. Fasten the truss very carefully against upward forces due to wind suction! This should be done with as many ropes as in detail A no. 3, i.e. 12 ropes.

Chapter 8: Bamboo reinforced concrete

- 8.1. - Introduction
Jules J.A. Janssen p. 164
- 8.2. - Bamboo Reinforcement of Concrete
McClure, pp. 7 ... 11 p. 165

Reference:

An article describing panels (600 mm x 600 mm x 10 mm) and planks (1800 mm x 1800 mm x 40 mm), made of concrete with bamboo fibres, is written by P.D. Smith, in: *Appropriate Technology*, vol. 6 no. 2, august 1979, pp. 8 - 10; edited by I.T.D.G. London.

8.1.

Introduction by dr. Jules J.A. Janssen

Bamboo as reinforcement of concrete has the advantage to replace a steel reinforcement; steel is expensive, and requires sometimes foreign currency, but bamboo is cheap and a local material.

However, there are also two main disadvantages. The first is: the dimensions of the bamboo depend on the moisture content. The moisture content varies with that of the concrete and with climate, and as a result the dimensions of the bamboo change, disturbing the bond between the bamboo and the concrete.

The second disadvantage is the low value of the Young's modulus of bamboo. This value is the same, both for bamboo and for concrete. Steel reinforcement on the contrary has a Young's modulus which is ten to fifteen times that of concrete. As a result, steel really reinforces the concrete, and bamboo only keeps together the concrete.

Just because many people remain interested in bamboo reinforced concrete, a text on this topic is given now. It is from 1950 already, but still (in 1982) a very good text. (The original report from 1950 is out of print !).

Bamboo Reinforcement of Concrete

Published references to the use of bamboo in reinforcing cement concrete structures or parts thereof indicate that the practice has been followed to some extent locally, for some decades at least, in the Far East (China, Japan, and the Philippine Islands). During the 1930's several experiments were carried out in Europe, particularly in Germany and Italy, to test the performance of cement concrete beams reinforced with bamboo.

The most recent, comprehensive, and

readily available information on the subject is to be found in the report of a series of experiments carried out by and under the direction of Professor H. E. Glenn. Two important sections of this report are quoted here, in entirety:^{4/}

^{4/} H. E. Glenn. Bamboo Reinforcement of Portland Cement Concrete Structures, pp. 123-127. Clemson College Engineering Experiment Station, Bul. 4. Clemson, S. C. May 1950.

Summary of Conclusions From Results of Tests on Bamboo Reinforced Concrete Beams

Below is given a summary of the conclusions as indicated from the results of tests on the various beams included in this study.

1. Bamboo reinforcement in concrete beams does not prevent the failure of the concrete by cracking at loads materially in excess of those to be expected from an unreinforced member having the same dimensions.
2. Bamboo reinforcement in concrete beams does increase the load capacity of the member at ultimate failure considerably above that to be expected from an unreinforced member having the same dimensions.
3. The load capacity of bamboo reinforced concrete beams increased with increasing percentages of the bamboo reinforcement up to an optimum value.
4. This optimum value occurs when the cross-sectional area of the longitudinal bamboo reinforcement was from three to four percent of the cross-sectional area of the concrete in the member.
5. The load required to cause the failure of concrete beams reinforced with bamboo was from four to five times greater than that required for concrete members having equal dimensions and with no reinforcement.
6. Concrete beams with longitudinal bamboo reinforcement may be designed to carry safely loads from two to three times greater than that expected from concrete members having the same dimensions and no reinforcement.
7. Concrete beams reinforced with unseasoned bamboo show slightly greater load capacities than do equal sections reinforced with seasoned untreated bamboo. This statement was valid so long as the unseasoned bamboo had not dried out and seasoned while encased in the concrete when the load was applied.
8. When unseasoned untreated bamboo was used as the longitudinal reinforcement in concrete members, the dry bamboo swelled due to the

- 12) 8000 - 10000 psi = 55 to 70 N/mm²
13) 5000 - 6000 psi = 35 to 40 N/mm²

absorption of moisture from the wet concrete, and this swelling action often caused longitudinal cracks in the concrete, thereby lowering the load capacity of the members. These swell cracks were more likely to occur in members where the percentage of bamboo reinforcement was high. This tendency was lessened by the use of high early strength concrete.

9. The load capacities of concrete members reinforced with bamboo vary with the dimensions of the members.

10. The unit stress in the longitudinal bamboo reinforcement in concrete members decreased with increasing percentages of reinforcement.

11. The ultimate tensile strength of the bamboo in bamboo reinforced concrete members was not affected by changes in the cross-sectional area of the members so long as the ratio of breadth to depth was constant but was dependent upon the amount of bamboo used for reinforcement.

12. Members having the optimum percentage of bamboo reinforcement (between three and four percent) are capable of producing tensile stresses in the bamboo of from 8,000 to 10,000 pounds per square inch.

13. In designing concrete members reinforced with bamboo, a safe tensile stress for the bamboo of from 5,000 to 6,000 pounds per square inch may be used.

14. Concrete members reinforced with seasoned bamboo treated with a brush coat of asphalt emulsion developed greater load capacities than did equal sections in which the bamboo reinforcement was seasoned untreated or unseasoned bamboo.

15. When seasoned bamboo treated with a brush coat of asphalt emulsion was used as the longitudinal reinforcement in concrete members, there was some tendency for the concrete to develop swell cracks, especially when the percentage of bamboo reinforcement was high.

16. Care should be exercised when using asphalt emulsion as a waterproofing agent on seasoned bamboo as an excess of the emulsion on the outer perimeter of the culm might act as a lubricant to materially lessen the bond between the concrete and bamboo.

17. Concrete members reinforced with unseasoned sections of bamboo culms, which had been split along their horizontal axes, appeared to develop greater load capacities than did equal sections in which the reinforcement consisted of unseasoned whole culms.

18. Concrete members reinforced with seasoned sections of bamboo culms, which had been split along their horizontal axes and treated with a brush coat of asphalt emulsion, developed considerably higher load capacities than did equal sections in which the reinforcement was split sections of seasoned untreated bamboo.

19. When split sections of seasoned untreated large diameter culms were used as the reinforcement in a concrete beam, longitudinal cracks appeared in the concrete due to the swelling action of the bamboo. This cracking of the concrete was of sufficient intensity as to virtually destroy the load capacities of the members.

20. When unseasoned bamboo was used as the reinforcement in a concrete member, the bamboo seasoned and shrank over a period of time while encased in the concrete. This seasoning action of the bamboo materially lowered the effective bond between the bamboo and concrete with a resultant lessening of the load capacities of the members.

21. Increasing the strength of the concrete increases the load capacities of concrete members reinforced with bamboo.

22. Concrete members reinforced with seasoned bamboo treated with methylolurea did not develop greater load capacities than did equal sections in which the bamboo reinforcement was seasoned culms treated with a brush coat of asphalt emulsion.

23. The load capacities for concrete members reinforced with unseasoned, seasoned or seasoned and treated bamboo culms, were increased by using split bamboo dowels as the diagonal tension reinforcement along the sections of the beams where the vertical shear was high.

24. The load capacities for concrete members reinforced with unseasoned, seasoned or seasoned and treated split sections of bamboo were increased by the use of a combination of split dowels and the bending up of the upper rows of the split bamboo from the bottom of the beam into the top and covering the sections of the beams where the vertical shear was high.

25. Ultimate failure of bamboo reinforced concrete members usually was caused by diagonal tension failures even though diagonal tension reinforcement was provided.

26. A study of the deflection data for all the beam specimens tested indicated:

(a) That the deflections of the beams when tested followed a fairly accurate straight line variation until the appearance of the first crack in the concrete.

(b) Immediately following this first crack, there was a pronounced flattening of the deflection curve (probably due to local bond slippage) followed by another period of fairly accurate straight line variation, but at a lesser slope, until ultimate failure of the member occurred. This flattening of the deflection curve was more pronounced in the members where the amount of longitudinal bamboo reinforcement was small.

(c) In all cases noted, the deflection curve had a lesser slope after the appearance of the first crack in the concrete, even though high percentages of bamboo reinforcement were used.

27. No pronounced variations were observed when the behavior of bamboo reinforced concrete members under flexure and having "tee" sections was compared with that of equal members having rectangular sections.

28. Bamboo reinforced concrete members under flexure and consisting of "tee" sections were no more effective than were equal rectangular sections, provided the breadth of the stem of the "tee" section was equal to that of the rectangular section and the effective depth of both were the same.

Design and Construction Principles Recommended for Bamboo Reinforced Concrete

1. In important concrete members, the use of whole culms of green, unseasoned, bamboo is not recommended as the reinforcing material. In concrete slabs and secondary members, green, unseasoned, whole culms may be successfully used when the diameters of the culms do not exceed three-fourths of an inch. When possible, the bamboo used as reinforcement in concrete members, subject to flexure, should be cut and allowed to dry and season from three weeks to one month before using.

2. The use of bamboo culms as reinforcement in concrete members subject to flexure cut in the spring or early summer seasons of the year is not recommended. Only those culms which show a pronounced brown

8) 3000 - 4000 psi = 20 to 30 N/mm²

color should be selected for use from a native bamboo grove. This practice will insure that the culms selected are at least three years old.

3. When thoroughly seasoned whole bamboo culms are to be used as the reinforcement in important concrete members subject to flexure, some type of waterproofing is recommended.

4. When seasoned sections of bamboo split from large diameter culms are to be used as the reinforcement in concrete members under flexure, some type of waterproofing is recommended for the bamboo in all important load carrying members. However, for slabs and secondary members and where the concrete sections are of a size as to allow the placement of the bamboo with a clear distance of from 1½ to 2 inches between the individual bamboo splints and between successive layers, the use of unseasoned sections of bamboo is recommended provided high early strength cement is used. In no case should the split bamboo sections have a width in excess of three-fourths of an inch.

5. The use of vertical split sections of bamboo culms is recommended to provide for diagonal tension stresses in members under flexure covering the portions of the member where the vertical shear is high and where it is impractical to bend up the main longitudinal bamboo reinforcement for this purpose. In continuous members and where otherwise practical, the practice of bending up the main longitudinal bamboo reinforcement at points of heavy shear to provide for diagonal tension stresses is recommended. Also, in all cases where it is practical, a combination of the above methods is recommended.

6. Proper spacing of bamboo reinforcement is very important. Tests indicate that when the main longitudinal bamboo reinforcement is spaced too closely, the flexural strength of the member is adversely affected. Also, when the main longitudinal bamboo reinforcement is used in vertical rows and when the top row is near the neutral axis of the member, the area of concrete at this section in horizontal shear may be sufficiently lessened as to cause failure of the member due to horizontal shear. In many of the specimens tested under flexural loads, the cause of failure was attributed to horizontal shear; however, in most instances where failure was from this cause, horizontal cracks existed in the concrete due to the swelling action of the bamboo reinforcement.

7. In placing the bamboo reinforcement, care should be taken to alternate the basal and distal ends of the bamboo culms in all rows. This practice will insure a fairly uniform cross-section of the bamboo reinforcement throughout the length of the member and the resultant wedging effect that will be obtained will materially increase the bond between the concrete and bamboo.

8. The design of structural members of bamboo reinforced concrete for flexural loads will be governed by the amount of deflection that can be allowed for the member. In all concrete members subject to flexural loads, a high degree of deflection is obtained in the member before failure occurs. Due to this high deflection, failure of a bamboo reinforced concrete member usually occurs due to other causes considerably before the bamboo reinforcement reaches its ultimate tensile strength. Design values, not in excess of from 3000 to 4000 pounds per square inch for the allowable tensile stress of the bamboo reinforcement, must usually be used if the deflection of the member is to be kept under 1/360 of the span length. When this low design value is used for a bamboo reinforced concrete member under flexural loads, a high factor of safety against ultimate failure of the member usually results.

9. The same procedure as that used for the design of structural con-

crete members reinforced with conventional steel is recommended for the design of concrete members reinforced with bamboo. Values have been recommended for the allowable unit bond stress between concrete and bamboo, for the allowable unit tensile stress in the longitudinal bamboo reinforcement and for the modulus of elasticity for bamboo. These recommended values should be used in designing a concrete member reinforced with bamboo for flexural loading. It is also recommended that "tee" beams be designed as rectangular beams ignoring the flange width in the calculations.

10. Some of the important characteristics of concrete members reinforced with bamboo on which future research should be done include:

- (a) Use of those species of bamboo in which the modulus of elasticity is higher than that of the species used in these experiments.
- (b) More exact data on diagonal tension reinforcement.
- (c) Further tests of the use of green uncured bamboo culms as the reinforcement where the conditions are such that the bamboo will be completely seasoned while encased in concrete.
- (d) More exact data on the bond between concrete and bamboo.
- (e) The use of other waterproofing agents than those used in these tests to insure against the swelling action of seasoned bamboo when placed in wet concrete.

It is obvious, from this very comprehensive and carefully considered series of statements, that the reinforcement of cement concrete with bamboo cannot be undertaken with confidence until a great many factors have been considered. Careful and expert attention to many details in execution is essential to success. Severe limitations must be taken into consideration. Apparently, the bamboo reinforcement of non-load-bear-

ing members, such as wall panels and floors resting on well-compacted earth, has more to recommend it, from the practical point of view, than the bamboo reinforcement of load-bearing members of a structure.

Chapter 9: References and index

9.1. - References

p. 173

9.2. - Index

p. 177

9.1. REFERENCES

1. The Use of Bamboo and Reeds in Building Construction.
Edited by United Nations, New York, 1972.
Sales no. E.72.IV.3.
Price U.S. \$ 3.00 95 pp.

Cutting, curing and storage	pp. 2 ... 10
Physical characteristics and structure	pp. 11 ... 18, 90
Preservative treatment against insects, rot and fire	pp. 19 ... 27, 91, 92
Building with bamboo and reed (split bamboo, mats, foundations, framing, flooring, roofing, walls, trusses, doors and windows, pipes and troughs, joints and fasteners)	pp. 28 ... 69
Reinforcement in concrete	pp. 70 ... 75
Bamboo and reed species, English and local names all over the world	pp. 81 ... 89
Tools	pp. 93 ... 95

- 2A. Bambu, su cultivo y aplicaciones. (in spanish)
Oscar Hidalgo Lopez.
Colombia, 1974.
Price U.S. \$ 27.00 318 pp.
Estudios Technicos Colombianos Limitada.
P.O. Box 50085, Bogota, Colombia.

Content:

Generalidades	pp. 5 ... 24
Cultivo	pp. 25 ... 26
Silvicultura	pp. 57 ... 68
Fabricacion de papel	pp. 69 ... 82
Construcction (fysical and mechanical properties, advantages and disadvantages, preservation, joints, reinforcement in concrete)	pp. 83 .. 178
Arquitectura (buildings of bamboo)	pp. 179 ... 244
Ingenieria (planes, hanging bridges, other bridges, water pipes)	pp. 245 ... 282
Artesana (beautiful woven bamboo)	pp. 283 ... 307

This book is worth its price.

- 2B. By the same author with the same editor:
 Nuevos Tecnicos de Construccion con Bambu.
 (also in spanish)
 137 pp. U.S. \$ 9.00 (1978)
 Content a.o.:
- A-frames for coffee drying,
 - low-cost housing,
 - soil-cement plaster on a split bamboo base as roofing material,
 - bamboo reinforced cement and concrete for water containers, flat panels, beams.
3. Bambus als Baustoff (in german).
 Klaus Dunkelberg.
 1980. 286 pp. Price now known.
 Rudolf Habelt Verlag,
 Am Buchenhang 1,
 53 Bonn 1, Germany
 Content:
- | | |
|---|---------------|
| Bambus als Pflanze | pp. 5 ... 21 |
| Materialeigenschaften | pp. 22 ... 40 |
| Verarbeitung von Bambus-Material | pp. 40 ... 56 |
| Bambus-Haus | pp. 59 ... 77 |
| (an excellent report on bamboo housing in Asia, as visited by the author) | |
| Halle, Gerüst, Steg und Brücke | pp. 78 ... 84 |
| Vor- und Nachteile | pp. 85 ... 86 |
| Abbildungen | pp. 93 .. 286 |
| (excellent pictures and drawings) | |
4. Bamboo.
 R. Austin and K. Ueda.
 Edited by Weather Hill, New York and Tokyo.
 Second edition 1972. 216 pp.
 ISBN 0-8348-0048-9
 Wonderful pictures, with a good text.
 Price about US \$ 26.
 Not for the field practitioner, more specific for those who love nice books, and bamboc.
5. Bamboe.
 The Dutch edition of this manual, however not a pure translation. Most of the content is similar, but there exist some differences.
 For sale with TOOL, Amsterdam.
6. Bamboo trusses.
 A manual how to build bamboo-trusses, as described in this manual on pages 142 - 161. Many pictures, and scarcely any text, in English (a French and Spanish edition are under preparation).
 Just for the field-practitioner.
 Will be edited in 1982, for sale with TOOL and ITDG.

7. Bamboo in Building Structures.
 Jules J.A. Janssen
 Doctor's thesis TH Eindhoven, 1981, 235 pp.
 Content:
- | | | |
|---|-------------|-----|
| Introduction | pp. 11 ... | 17 |
| The biological composition of bamboo | pp. 19 ... | 28 |
| Models of Cell and Cell Wall
(calculations of the stresses in
the fibre) | pp. 29 ... | 74 |
| Mechanical properties
(compression, bending, shear,
tension, rules of thumb for practical
use) | pp. 75 ... | 152 |
| Joints and trusses
(report on the research-programm) | pp. 153 ... | 226 |
| Conclusions and recommendations | pp. 227 ... | 235 |
- Price U.S. \$ 12 plus airmail.
 Address:
 Dr. J.J.A. Janssen
 395 de Koppele
 5632 LN Eindhoven
 the Netherlands
8. Bamboo for House Construction.
 G.C. Mathur
 National Building Organisation, New Delhi, 1964; pp. 36
 A very good booklet, short and clear.
 Content: advantages and defects of bamboo houses, treatment,
 walls, roofing, joints, foundations, reinforcement in
 concrete, doors and windows, matting, ceilings, flooring,
 boards, tiles, pipes and drains.
9. Wood and Bamboo for Rural Water Supply.
 See p. 122.
10. McClure,
 Bamboo as a Building Material.
 Originally edited by the U.S. Department of Agriculture,
 Washington, 1953.
 Reprinted by Peace Corps, 1979.
11. Bamboo Research in Asia.
 Proceedings of a Workshop held in Singapore 28 - 30 May
 1980.
 228 pp.
 Edited by I.D.R.C., box 8500, Ottawa, Canada, KIG 3 H9.

12. Bamboo Production and Utilization.
Proceedings Congress Group 5.3A on IUFRO World Congress,
Kyoto, Japan, 6-17 September 1981.

Editor:

Takayoshi Higuchi

Director Wood Research Institute

Kyoto University

Kyoto Fu 611

Japan.

Nrs. 11 and 12 are reports on meetings of scientists !!

9.2.

Index

	<u>chapters or pages in this book</u>	<u>references on pages 173-175</u>
- General		1, 2, 3, 4
botanical species		1
cultivation		1, 2
cutting		1
preservation	9-19	1
tools	72-76	1, 3
splitting and weaving		2, 3
- Building		1, 2, <u>3</u> , 8
housing	Ch. 2,	<u>3</u>
roofs	32, 33,	
walls	25, 54	2, 3
floors	25, 54, 134	
doors and windows	26, 70-71	2, 3
fire		1, 3
rats	34-61	
(dis)advantages	5-8	2, 3, 7
- Construction	Ch. 7	
joints	133-135	1, 2, 3, 7
trusses	142-161	<u>6</u> , <u>7</u>
mechanical properties	136-141	1, 2, 3, <u>7</u>
reinforcement in concrete	Ch. 8	1, 2
- Paper		2
- Water Pipes	Ch. 6	2, <u>9</u>
- Civil engineering		
bridges etc.	Ch. 3	2
roads	Ch. 4	
boats and rafts	Ch. 5	