

**AT** MICROFICHE  
REFERENCE  
LIBRARY

A project of Volunteers in Asia

Practical Poultry Raising  
Peace Corps ATFD Manual No. M-11

by: Kenneth M. French

Published by:  
Peace Corps  
Information Collection and Exchange  
806 Connecticut Avenue, N.W.  
Washington, DC 20525 USA

Available from:  
Peace Corps  
Information Collection and Exchange  
806 Connecticut Avenue, N.W.  
Washington, DC 20525 USA

Reproduction of this microfiche document in any form is subject to the same restrictions as those of the original document.

# **Practical Poultry Raising**

**Peace Corps**

INFORMATION COLLECTION & EXCHANGE

MANUAL M-11

## INFORMATION COLLECTION & EXCHANGE

Peace Corps' Information Collection & Exchange (ICE) was established so that the strategies and technologies developed by Peace Corps Volunteers, their co-workers, and their counterparts could be made available to the wide range of development organizations and individual workers who might find them useful. Training guides, curricula, lesson plans, project reports, manuals and other Peace Corps-generated materials developed in the field are collected and reviewed. Some are reprinted "as is"; others provide a source of field based information for the production of manuals or for research in particular program areas. Materials that you submit to the Information Collection & Exchange thus become part of the Peace Corps' larger contribution to development.

Information about ICE publications and services is available through:

Peace Corps  
Information Collection & Exchange  
Office of Programming & Training Coordination  
806 Connecticut Avenue, N.W.  
Washington, D.C. 20525



Add your experience to the ICE Resource Center. Send materials that you've prepared so that we can share them with others working in the development field. Your technical insights serve as the basis for the generation of ICE manuals, reprints and resource packets, and also ensure that ICE is providing the most updated, innovative problem-solving techniques and information available to you and your fellow development workers.

# Peace Corps

# Practical Poultry Raising

Written by:

**Kenneth M. French**

Edited by:

**Larry Ritter**

Illustrated by:

**Marilyn Kaufman**

This publication was produced  
for Peace Corps by TransCentury  
Corporation, Washington, D.C.

Peace Corps  
Information Collection & Exchange  
Appropriate Technologies for Development  
Manual Number 11  
April 1981

**PRACTICAL POULTRY RAISING**  
**February, 1981**

Prepared for the Peace Corps by  
TransCentury Corporation  
under Contract No. 79-043-1029

Available through  
Peace Corps Information Collection  
& Exchange  
806 Connecticut Avenue, N.W.  
Washington, D.C. 20525

## About this Manual

This manual is designed to provide development workers with the information and tools needed either to begin or to improve poultry production. For those who are inexperienced in poultry production, this manual can identify and provide the basic information needed to raise and market poultry successfully. More experienced poultry workers may find the manual sections on cultural considerations, nutrition, extension and additional resources useful for adapting their knowledge and skills to the conditions of a new environment. No matter what your previous level of poultry experience, you can help expand poultry production by helping farmers observe, question and find the gaps between actual and potential production, by suggesting improvements and by helping farmers evaluate the results.

Numerous sources were consulted in the preparation of this manual in order to make it useful for raising poultry under varying conditions.

This manual explores many different aspects of raising and marketing poultry based upon these sources and the author's and reviewers' experiences. Because ideas about poultry production vary greatly in different countries, IT IS HIGHLY RECOMMENDED WHEREVER POSSIBLE THAT A REVIEW OF THIS MANUAL BY A RESPONSIBLE OFFICER WITHIN THE APPROPRIATE GOVERNMENT MINISTRY BE PERFORMED BEFORE THE SUGGESTIONS MADE IN THE MANUAL ARE IMPLEMENTED. There are special climatic considerations, feed ingredient problems, disease considerations and so on which can make sections of this manual inappropriate in certain areas of the world. If there are questions about the appropriateness of recommendations made in the manual, the experience of local authorities should have priority until research can be done to show the value of the new methods. It should be noted also that sources consulted for this manual do not always agree. On one issue, four highly experienced sources each gave different recommendations for the same conditions. To make this manual

most useful, methods and tools described are based either on a majority opinion or upon the experience of the author.

Because this manual gives general instructions on poultry production, some recommendations and suggestions will not be relevant to every development worker's situation. Poultry workers will need to adapt methods and tools to their own specific needs. We would appreciate, therefore, your comments, corrections and suggestions for future editions of this manual. What information was the most useful? What was not covered that would be useful in revised editions? How did you use this manual? What was irrelevant or not useful? Please make comments and let us know how this manual helped you in poultry production.

## About the Author

Kenneth M. French has over fifteen years of experience in agriculture and rural development both in the United States and abroad. As a Peace Corps Volunteer in India, he conducted a scientific breeding program for poultry over a three-year period. Based on this experience and his own farming background, Mr. French served as a technical and cross-cultural trainer for Peace Corps Volunteers in India in poultry breeding and rural development projects. As the Associate Director of Peace Corps/Malaysia, Mr. French was responsible for all Peace Corps rural agricultural development pro-

jects in Malaysia, supervising fifty Volunteers in fifteen areas. Projects under his direction included agriculture extension in crops and dairy management, rural credit, soil fertility research and conservation, forestry management and marketing systems. Mr. French's writing experience includes policy papers for the Malaysian Ministry of Agriculture on agriculture extension, cooperative development and agriculture marketing. Mr. French has formal training in agriculture from the University of New Hampshire, where he majored in poultry science.



## Acknowledgments

As with any manual, many people have contributed to the development of Practical Poultry Raising. The author is grateful especially to Walter S. Staples, Russ Staples and P.K. Nambiar, who reviewed the manual for technical accuracy and provided encouragement along the way. Peace Corps' Whett Reed oversaw technical aspects of the manual from the Peace

Corps perspective. Many thanks go to TransCentury's Paul Chakroff, project manager under whose direction this manual was prepared, and to Pamela Ball for assistance in coordination. Thanks are due also to Marilyn S. Chakroff who edited, organized and coordinated the final production of this manual and to Linda Gusman for typing and layout.

# Table of Contents

	<u>Page</u>
About this Manual	i
About the Author	iii
Acknowledgments	iv
1. Poultry Production -- An Overview	1
2. What Do You Have to Work With?	9
3. Getting to Know the Chicken	21
4. Working with Country Chickens	31
5. Poultry Husbandry	41
6. Housing and Equipment	81
7. Keeping Chickens Healthy	115
8. Feed and Nutrition	131
9. Poultry Marketing and Finances	153
10. Poultry Extension	169
<u>Appendices</u>	
A. Housing Designs	175
B. Other Poultry	185
Ducks	185
Geese	186
Guinea Fowl	188
Turkeys	189
Pigeons	190

	Page
<u>Appendices-continued</u>	
C. Farmer Specific Assessment Criteria	193
D. Feed Formulation Chart	197
E. Feed Requirements	203
F. Bibliography and Resources	207
Glossary	211
Index	213

# 1. Poultry Production— An Overview

## What is Poultry?

The word poultry applies to all domestic fowl raised for their eggs, their meat, or both. Poultry includes chickens, turkeys, ducks, geese, guinea fowl, pheasants, quail and pigeons. Chickens by far are the most popular poultry raised today, and this manual will concentrate on them. A brief section on other fowl is given in Appendix B (p. 185).

The first chickens (probably the species Gallus gallus) were lured or captured from the rain forests of Southwest Asia over 3,000 years ago. Since that time, chickens have been kept for meat and eggs by nearly every human group throughout the world. Over the years, the original chicken has been bred by selection and circumstance into many

varieties.

Until recently almost all chickens were raised in small flocks and left to look after themselves. In many areas of the world chickens still are raised a few at a time for occasional eggs or to serve at a feast. There are people today who grow chickens only for cock-fighting or religious ritual. Some types of chickens with beautiful plumage are raised just for show.

In the past 40 years, the growing need for protein to feed the world's rapidly expanding population has caused farmers and scientists to pay more attention to chickens as food sources, and to increase the efficiency with which they are raised. Genetic research has developed many

different breeds and varieties adapted to different climates, farming methods and purposes.

### Types of Chickens

Even though there are many different breeds and varieties of chickens used in farming, they all can be divided into three types:

Layers -- Bred primarily for egg production, these birds usually weigh about 1-2 kilograms (kg) (2.2 to 4.4 pounds). They are lighter than chickens bred to produce meat. Because they are smaller, they need less feed to maintain their body weight while laying as many or more eggs than the big birds. The layers also are eaten, usually after they have been producing eggs for a year to a year and a half. Farmers often do not keep the males of these breeds because it takes too much feed to bring them to a marketable weight. Birds that lay brown eggs usually are a little larger than those that lay white eggs.

Meat Chickens -- These birds grow

rapidly and reach marketable size after two to three months. They are sold well before they reach egg-laying age. Whether a meat chicken is called a fryer or a roaster depends on its size and age. Meat chickens usually are called broilers. Capons (castrated males) grow large, fat and tender as they get older.

Dual-Purpose Chickens -- These birds are raised for both eggs and meat. Females of the new, improved breeds are kept to lay eggs while the males are separated and sold for meat as soon as they reach about 15 weeks of age. Also, dual-purpose hens are sold for meat at the end of the laying time. The country chickens roaming free in most villages of the world are a kind of dual-purpose bird. Generally, it is more profitable to specialize in either layers or meat birds, for these improved breeds of chickens can reach very high levels of production. Some layers now produce at an average rate of 90% for a whole year. Meat chickens weighing 2 kg or more are ready for market in seven to ten weeks. However, unlike country fowl which, through many

centuries, has developed resistance to many diseases and learned to take care of itself, these new breeds need the active care of the farmer to protect them from disease and predators if they are to survive and produce well.

### **Why Raise Poultry?**

Small Poultry Flocks -- anything from a hen and a few chicks running free up to a group of 50 or so that receive some special care -- can provide a family with important protein in its diet and perhaps some income through the sale of extra eggs and birds to neighbors. Feeding the birds food scraps and crop by-products is a good way to use vegetable matter that the family doesn't eat. But, if country chickens are used, they will not produce very much, and it is difficult to use the new breeds efficiently in small numbers. By keeping costs low, some farmers can make sufficient profit on a small flock to allow for expansion to a larger

flock.

Medium-Size Flocks -- one or two hundred birds or more -- can increase significantly the local supply of high-quality protein, minerals and vitamins. This is especially important for young children and for pregnant and nursing mothers. These flocks also can:

- increase family income;
- increase local employment;
- use food processing by-products that normally are wasted;
- use relatively little land (chickens can be kept by urban as well as rural people);
- increase the supply of manure for fertilizer and methane gas production; and
- provide possible benefits when combined with other protein increase programs (for example, chicken manure can be used to fertilize fish ponds).

### **What Are the Disadvantages?**

Of course, there also are possible disadvantages to raising chickens. Some people say that livestock in general are inefficient producers of food and that most developing

nations cannot afford to use their scarce resources to raise them. By growing such crops as soybeans, they say, farmers can produce much more protein per acre. Livestock also often compete directly with humans for cereal grains such as wheat and maize (corn). But much agricultural land isn't suited for growing protein crops. Chickens eat less per unit of protein produced and require less land than other livestock. They also can be raised on diets containing foods not usually eaten by humans. Chickens provide high quality protein that is particularly well suited to human digestive systems and dietary needs.

Medium-size poultry operations in developing nations have other possible disadvantages:

- Poorly run projects can destroy a small farmer's scant savings or put him deeply into debt;
- Market cycles can hurt or destroy a poultry project, even if it is well run;
- Feed, water or labor stoppages can cause failure;
- These projects need specially-bred birds, pharmaceuticals, markets, transport and tech-

nical advice that may not be found in your area;

- Compared to traditional ways of raising chickens, these projects need a large investment per bird.

After considering the advantages and disadvantages, most developing nations have decided to encourage poultry production. This encouragement has not yet reached many small farmers. Here is where you may be able to help.

### **What Do You Need to Raise Poultry?**

Just as humans have certain minimum requirements for life, there are basic chicken needs which must be provided for by the farmer if the birds (especially the new breeds) are to be productive. These include: shelter; protection from disease, pests and predators; temperature and humidity controls; sanitation; control of light; and elimination of stresses.

Examples of stresses are: noise and other disturbances; dust; drafts; foul or stale air; crowding; changes in feed; introducing new chickens

into established flocks; changes in weather; and keeping males with females. Stress factors are additive, that is, the more that a chicken has to bear, the worse the effect may be. An otherwise healthy bird may contract only a mild case of a disease when exposed to it; a bird that has worms, is crowded, or is not eating well may die when exposed to the same disease.

The most important element in poultry raising is a good relationship between the caretaker and the flock. A caretaker must like and understand chickens and be dedicated to seeing that they do well. In short, chickens need tender loving care.

### **What Do You Need to Expand Beyond the Farmyard Flock?**

Interested Farmers -- Unless farmers are convinced that poultry raising is a good idea and are ready to provide the constant care and attention, finances and other support that larger flocks need, there is no point in going on. You cannot and should

never attempt to persuade farmers to do something that they don't think is in their best interest.

Cultural Acceptability -- The chicken has been linked with human society for so long that many cultures have developed special ways of dealing with them. Vegetarians, of course, don't eat chicken meat and many don't eat eggs, especially fertilized ones. Other societies relish eggs in which the fetus already is formed. Some people regard fowl as sacred and will not eat them, while others won't touch them because of the worms and manure that chickens sometimes eat. Some cultures forbid eggs to pregnant women. There are many other such taboos and traditions throughout the world. In most places, however, people welcome chickens and eggs to their menus and willingly form a good market, but you must learn from local people about their customs and attitudes if you are to work effectively.

Financial Means -- Farmers must have available cash of their own, be able to pool their resources through cooperative efforts or be able to borrow from private sources or government



agencies. For small farmers, investing in the new breeds means that a large portion of their resources is not available for other uses. They must realize that they risk losing part or all of their investment. Even if they do make a profit, it may not be for some time--in layer operations this may take at least one and a half years, sometimes longer.

#### Local Supplies and Technical Support

-- You must have an assured supply of clean water and fresh, well-balanced feed for the life of the birds. This is easier to arrange for meat birds that are kept for only a few months than it is for layers that will need vaccines, medicines and food supplements, and advice on how to use them.

Markets and Infrastructure -- Even if the people in your area enjoy eating chickens and eggs, they may be too few or too poor to justify an expanded chicken operation. Transport problems may mean that you cannot deliver your products, especially eggs, to market quickly enough so that they are fresh, attractive and earn a profit. Farmers near towns

or good roads usually have a good market, even though competition may reduce their per bird profit. Those in remote areas often can't sell as many eggs and birds, but may make up for that by receiving higher prices.

Breed Source -- A farmer who wants to start a medium-size poultry operation will need a source of an improved breed. Ways to work with and upgrade flocks of country chickens are described in Chapter 4 (p. 37), but if farmers are to spend their limited resources on buildings, feed or other support, they should use birds with the greatest genetic potential.

Market Plans -- Farmers will have to determine: when to start their flocks so they are ready for laying or sale in the most profitable season; which types of eggs and meat are most enjoyed by buyers; what quantities realistically can be sold if neighboring farmers also are expanding; what to do about other seasonal problems such as scarcity of labor during harvests, lack of water during dry seasons, and so on. These topics are discussed in Chapter 9 (p. 153.)

## **Where Has Poultry Development Worked Well?**

Many developing nations have made big gains in their poultry industries in recent years. Poultry development in India serves as a good example of the way a developing country can increase its protein production.

### Poultry Development in India

Most of India's poultry development has happened in the past 20 years. A country with minimal cereal grain resources, India faced many other problems as well. Many farmers could not afford even a small backyard poultry operation. The vast majority of Indians are vegetarians. There were transport problems, and difficulties with feed and medical supplies. Extension personnel were few, and though some were dedicated, others were not. Most areas had no poultry feed analysis laboratories. All viable improved breeds (breeds in which a high percentage of chicks live and turn into good producers) were being imported, usually through multinational corporations. Farmers

were accustomed to traditional ways of raising chickens and were reluctant to change to new methods until they were proven.

While a few neighboring countries have had little success with poultry, India has made much progress. Much of it is due to intensive, broadly-based extension work, some of it done by Peace Corps Volunteers. Once farmers began taking advantage of the extension service, bought and raised better birds and found they were making money, they began to demand more service and even better birds.

The government and others responded to the new demands by establishing tax incentives for poor farmers, setting poultry feed ingredient standards, building more feed analysis laboratories, issuing loans, insuring experienced farmers, improving government breeding programs, increasing vaccine production and delivery, providing better disease diagnostic services, and expanding extension activity.

Peripheral industries sprang up. Small shops began making poultry equipment such as brooders, feeders,

and supplies such as egg shipping cartons and baskets. Farmers in remote areas organized cooperative societies. With advice, loans and grants from the government and international agencies, the cooperatives began mixing feeds, buying supplies and equipment, building storage units and marketing members' products. They began contracting with farmers and rice mills, and growing their own feeds as well. Major breeding, pharmaceutical and feed supply companies also expanded and assisted farmers in more remote areas.

Marketing also had been a problem. The vast majority of Indians are Hindu, a religion which prohibits or discourages eating anything which is or has the potential to be animal life. It was believed that all eggs had the potential for life and therefore should not be consumed. Consumers were taught by poultry people and nutritionists that eggs could be produced without the presence of roosters and that a difference existed between the fertilized and unfertilized egg. Although some Hindus still will not eat them, most

have accepted unfertilized eggs as part of their diet.

Today, the number of eggs produced in India has increased 600%, from 2 billion in 1969 to over 12 billion in 1979. The growth of egg production has outpaced population growth, resulting in lower egg prices relative to family income.

What India is learning about chickens can be and is being learned in other developing nations. As a poultry production worker, you can help make poultry an important food and income source in your area.

# 2. What Do You Have To Work With?

## Assessing the Local Situation

If you are living in your work area, you probably already know quite a bit about the local poultry situation. You most likely have bought eggs and perhaps chickens in the market and know something about the quality and quantity available there. Do people present you with a chicken as a token of their esteem? Does a neighbor's rooster awaken you? Or have you found yourself downwind from a poorly run chicken coop? We tend to notice first the things that affect us personally.

If you want to see whether you can be useful in poultry production,

you must know much more about how the supply or lack of chickens affects the lives of the people around you. Do people eat eggs and chickens often or save them for festive occasions? Do local restaurants serve them daily? If so, where do they and the market sellers get their supplies? Is the neighbor's rooster or the upwind chicken coop unique, or are there many around? Do you think prices are high or low compared to other local foods? How do local prices compare with those in other areas of your country?

If you are in one of those rare

places without chickens, what are the reasons? It may be a temporary condition caused by a severe outbreak of disease, a drastic increase in the predator population or a long drought. In such cases, you may be able to help reintroduce chickens to the area. In other cases, where people won't eat eggs and chickens and don't want to have them around, you may want to find another activity entirely.

## **Which Management Systems are Used In Your Area?**

From the small backyard flock to the 100,000-bird automated house, poultry management systems can be classified in any number of ways. We have chosen the following six categories arbitrarily to give you a rough guide to what you may see in your area. You should observe local farmers closely, seeing which methods they use and why, finding out what

they think their problems are, and finding out what kind of improvements they would like. Unless you already know quite a bit about both chickens and people, you should limit yourself to questions, for your purpose now is to learn.

The descriptions and illustrations in this section are included only for the purpose of showing a progression of technology and the basic types of poultry operations. A view in your own village may differ somewhat, but the principles will be similar. Following chapters explain advantages and disadvantages of each of the six systems shown here.

### **Country Chicken, Free Range**

In this system the farmer makes no attempt to control the flock's food or water intake, although they may be thrown an occasional food scrap or handful of grain. The flock finds its own shelter and uses its instincts to avoid predators. The farmer provides no sanitation, and the only vaccinations that may

occur are given by government agents during widespread epidemics. The hen tries to hide her few, small eggs and often succeeds. She hatches her eggs on her own. The farmer

gets very few eggs, little meat and has very little of either to sell. Losses, especially of chicks, to disease, predators and theft are high.



## Partly Controlled, Free Range

In this system the farmer provides overnight shelter and some supplemental feed. Breeding is uncontrolled, but the farmer does provide a nesting place where a brood hen incubates her own eggs

and the farmer may place other hens' eggs under her as well. (A brood hen is a hen that wants to set and hatch eggs and take care of chicks.) The farmer may make use of the local agricultural extension system for some advice and vaccinations.

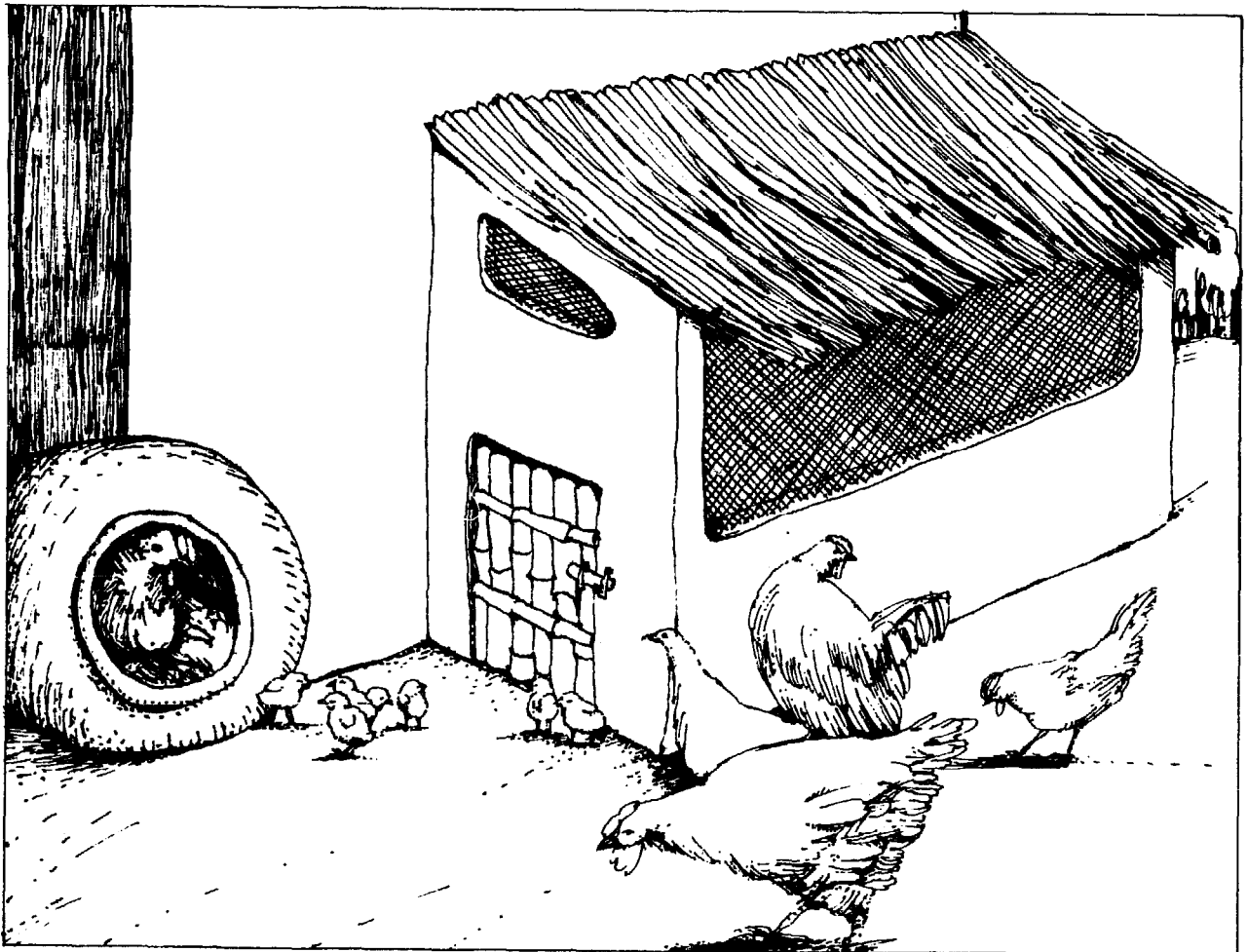

## Contained, with Limited Range

There are many variations of this system. The essential feature is that the flock is contained in a shelter overnight and during bad weather. At other times the chickens are free to eat any grass and other food they can find within a fenced yard or run. Sometimes the shelters are small and portable, have wire mesh floors and are moved frequently to fresh ground and grass within the yard. Other times the shelters are larger and

stationary. The chickens may be confined to one yard, or may be rotated every few months to fresh adjacent enclosures.

In limited range systems the farmer provides most, if not all, feed and water, sometimes outside as well as inside the house. The chickens may be either from local flocks or improved breeds. The farmer may have the benefit of technical advice beyond that available from neighbors. If the house is stationary, it may use either a

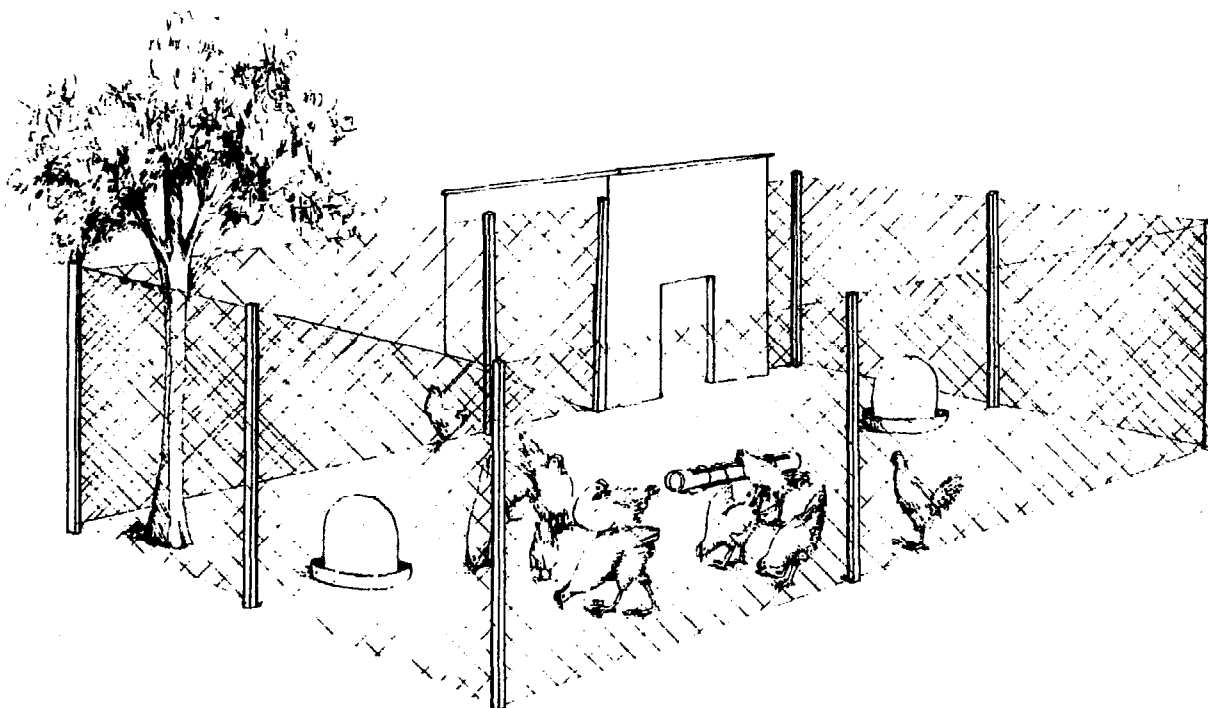



deep-litter or raised-floor system (see below).

### Contained, Deep Litter

In any contained system the chickens remain inside at all times. The breed source almost always is a commercial breeder. The farmer provides all feed and water, nesting boxes and perhaps perches (roosts) inside the house. The farmer usually

has the benefit of technical advice. Losses to predators, disease and theft are greatly reduced compared to previous systems. The contained system requires a substantial investment per bird.

The floor of a deep-litter house is covered with up to 15 centimeters (cm) of bedding material (wood shavings; rice, wheat or other grain hulls; shredded sugar cane or shredded straw, etc.) that absorbs moisture from droppings.

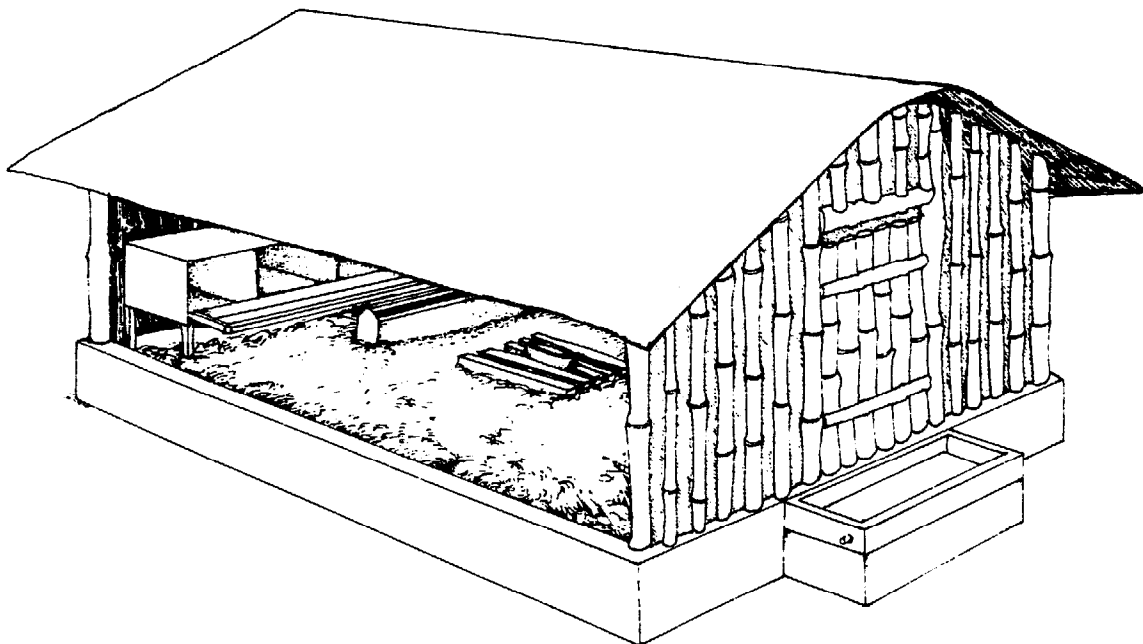

## Contained, Raised Floor

The characteristics of this system are the same as those of the deep-litter, except that the chickens live on a raised, semi-open floor, and droppings fall to the ground or to a light layer of litter below. The floors usually are made of spaced, wooden slats, but sometimes wire mesh or expanded metal is used. (Expanded metal is sheet metal which has been partially cut and stretched and looks like heavy gauge wire mesh with diamond-shaped holes.)

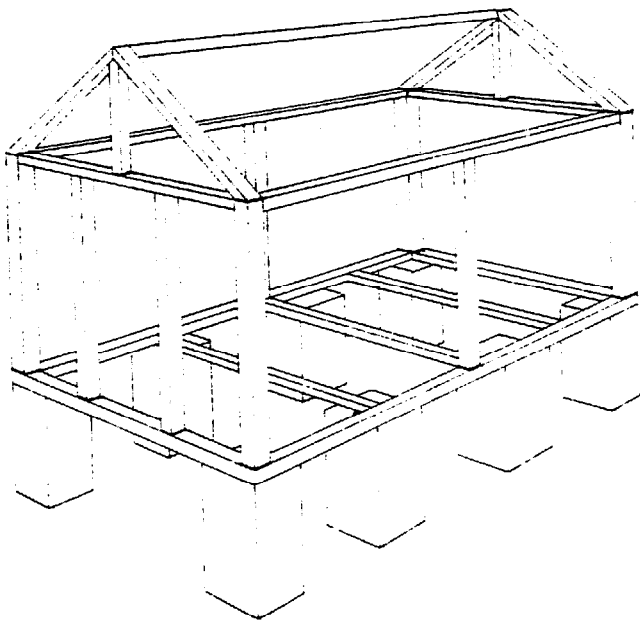

## Cage or Battery

This system is used only for layers. The hens live in cages where food and water are provided. The cages may be placed in any sheltered area. The farmer most likely uses extension advice. The investment per bird may be the highest of all systems, especially if the cages are made of expensive wire.

## Can You Help?

We assume that anyone in an area where no chickens are being raised and where there is little hope of introducing them already has traded this manual for other reading material. If you are in an area where large-scale poultry raising is abundant, egg and meat prices are very low, and there is little chance of you contributing unless you are a highly skilled technician, you should be looking for something else to do.

Both of the above situations

are rare in the developing world. Usually there is room for improvement of the existing situation. The more you learn about chicken raising in general and the specifics in your area, the better you will be prepared to help. The following chapters will give you essential facts and some useful ideas for suggesting local improvements. The bibliography lists more reading matter you can order. But before you dive deeply into technical material, there is an approach to working with people in development (in this case, poultry farmers or potential poultry farmers) that we suggest you keep in mind.

## Finding the Gap

Almost any poultry operation fails to reach its maximum production potential. You should try to assess the production potential in your area. What you are seeking is

not some idealized situation where no error can occur, but what reasonably can be expected by your friends and neighbors if they work willingly and seek good advice. There is no exact formula to determine the production potential, although this manual does give you some production averages that are fair guides. Local conditions and attitudes always will determine the final outcome.

As you gauge the technical potential and compare it to the present situation, you will see some degree of difference between them. Production potential minus the present situation equals the gap. You will be working to help fill this gap.

Address yourself to the local gap. Don't worry about the big difference between what you see and the results obtained in industrialized nations. Work with possible local advantages, such as: small investments of more time, money and energy may yield relatively large returns; labor and some supplies may be relatively inexpensive in your area; market prices may be high, and minor decreases in them may increase de-

mand exponentially as poorer people see they now can afford some eggs and meat.

## Filling the Gap

The key to filling the gap is increased control over production factors. This may mean introducing new methods and resources, or it may mean cutting the costs of those now in use. The gap between the existing and potential situations often can be overwhelming. If you attempt to change everything at once, you and the farmer are likely to become frustrated. To avoid this, break the gap down into smaller increments that the farmer can handle. For example, if chickens are overcrowded, in a poorly ventilated structure, have intestinal parasites and are not properly watered or fed, you can first suggest selling off a few chickens to reduce overcrowding, increase ventilation, and provide

proper food and water.

Although small, these changes will bring rapid results and are not costly. Then you can begin to address the other problems one at a time. Close the gap by helping farmers select increments that they can most easily absorb, and that have the best chances for early, observable results. This manual will describe most of the basic increments that may be of use and help you choose the ones you might suggest. To aid in determining the gap, use the Farmer Specific Assessment Criteria (Appendix C) for each farmer in your area.

## Evaluating Your Resources

Appendix F (p. 207) lists a few resources available to you, but most of them will be hard to obtain. It always is best to work with local resources. There should be many available if you seek them out.

## Government Agencies

Before beginning any poultry activities, you should consult with the government poultry agency, usually a part of the Ministry of Agriculture. The people there can tell you about the support they offer. It probably includes recommendations on:

- Vaccinations and medications -- dosages, schedules, equipment, emergency programs and free service available.
- Nutrition -- feed mix sources, ingredient sources, costs, seasonal fluctuations, what works best in your area.
- Building designs -- use of local materials, environmental considerations, cost reductions.
- Water supply -- availability, water-borne diseases and treatments.
- Equipment -- sources and designs.
- Stock -- sources of chicks and pullets (female chickens less than a year old), breeds available and which produce best.
- Financial assistance -- sources and application procedures.
- Laboratory facilities --where

they are and what they can do.

- Cultural considerations -- how to work with them.
- Local language extension publications -- how to obtain them.
- Topics not mentioned in this list -- there may be many.

## Private Companies

It is in their interest to have farmers do well. They often offer information and advice difficult to obtain elsewhere. However, if you have a choice of more than one firm in a field, it is best to check with several and try to balance the various self-interests. Firms to look for include:

- Breeding companies -- Unless they also are egg and meat producers who might feel threatened by possible competition, information that you receive from them should be good.
- Pharmaceutical companies -- They are good sources of information on diseases and their control.
- Equipment manufacturers -- This may be a local artisan

in a small market stall, a shop in a town or an import distributor. With their local experience they can help you cut costs and avoid mistakes.

- Feed suppliers -- They provide feeding recommendations with their ready-mixed feeds. If you plan to mix your own feed, they may advise you on the least costly ingredients and provide vitamin, mineral and protein supplements.

### **Cooperatives, Lending, Education and Research Institutions**

You should know where they are and what they can offer. Cooperatives are discussed in Chapter 9 (p. 153). Lending institutions are not just sources of finances, they also can provide information on how to reduce costs and risks. Universities, technical schools and research laboratories often are sources of much useful information.

### **International Technical Assistance Agencies**

Groups such as the United Nations Food and Agriculture Organization (FAO), the United States Agency for International Development (AID) and many others may have offices in your country where you can obtain helpful advice and publications. They may even have a resident poultry expert. Your local Peace Corps staff or Peace Corps' Information Collection & Exchange (ICE) may be able to put you in touch with a resource you need.

### **The Market Network, Local and Distant**

Everyone you meet who is engaged in poultry production and marketing can offer advice on prices, seasons, supplies, consumer preferences and so on. Sometimes their advice may be conflicting and confusing, but more often you will hear a consensus that leads you in the right direction.

The next three chapters describe various poultry care and marketing practices. Once you have these basics

in mind, you can use the suggestions in Chapter 9 (p. 153) to identify people who may want to try chicken raising or who want to improve their current operation. When they have expressed their needs, you and they can begin planning how to fill those needs.

# 3. Getting to Know the Chicken

Before planning any poultry production effort, you need some basic information about chickens. If you are inexperienced with these birds, you will need to become familiar with the parts of a chicken, the general appearance of a healthy bird and the differences between male and female chickens. You do not need to become an expert in chicken anatomy, but to work in poultry production you do need to know what the primary characteristics of chickens are, their normal life cycle and how to handle live birds. This chapter describes both external and internal anatomy of chickens; such information will be especially useful later on when diagnosing and treating chickens for disease.

## Characteristics of Chickens

Chickens come in many sizes and colors. They lay eggs which can range in color from pure white, to dark brown, to olive green, to speckled. The number of eggs an adult female lays in a year varies from none to 365, or one a day. The typical country chicken which has had no breed improvement usually will lay between 25 and 100 eggs per year, depending mostly on conditions such as feed, exposure to disease and predators, weather, and others. Layers usually start producing eggs between six and eight months of age, depending upon their health and the time of the year. The improved breeds start laying at five to six



months of age, and under good conditions will lay between 180 and 365 eggs yearly, with an average flock of 100 birds producing 240 to 280 eggs per layer. There also are improved breeds which are intended specifically for meat production. Chickens from such breeds can weigh over 2 kg at only seven to eight weeks of age.

Chickens hatch from fertilized eggs after 21 days of incubation. In poultry production, incubation can either be by natural means (a broody hen) or by artificial means (an incubator). Before hatching, chicks absorb the yolk of their egg into their lower body in the yolk sac. This yolk supplies them with enough food and water for up to two days, at which time they must begin drinking and eating on their own. Chicks hatch by breaking through an air cell in the large end of the shell. Using their upper beaks, chicks peck a hole through the shell, then continue to peck at it until the shell is weakened enough so that it can be entirely broken open. This process is called pipping.

At hatching, chicks are wet. Within a few hours they dry out and are covered with a soft down. The first feathers appear within a week on the wing tips and tail; other feathers grow in later.

Chickens mature at different rates, depending on breed, nutrition and environmental factors. Most will be mature by six months of age. Males are called cockerels until they reach maturity, when they are called roosters or cocks. Before reaching maturity, female chickens are called pullets; once they begin laying, they are called hens. Some farmers will refer to a whole flock of female chickens as pullets until the entire flock reaches full egg production.

## Anatomy of Chickens

To be able to work with chickens, you first must know the various parts of a chicken and their functions, and

how to tell male and female chickens apart. The major external parts of a chicken include these:

- Beak -- The chicken's beak serves three functions. First, it is the chicken's mouth. Second, it is used

for fighting and protection. And third, it functions as the teeth of the chicken, enabling the bird to break grass, bananas and other foods into pieces small enough to swallow.

- Comb and wattles -- It is be-

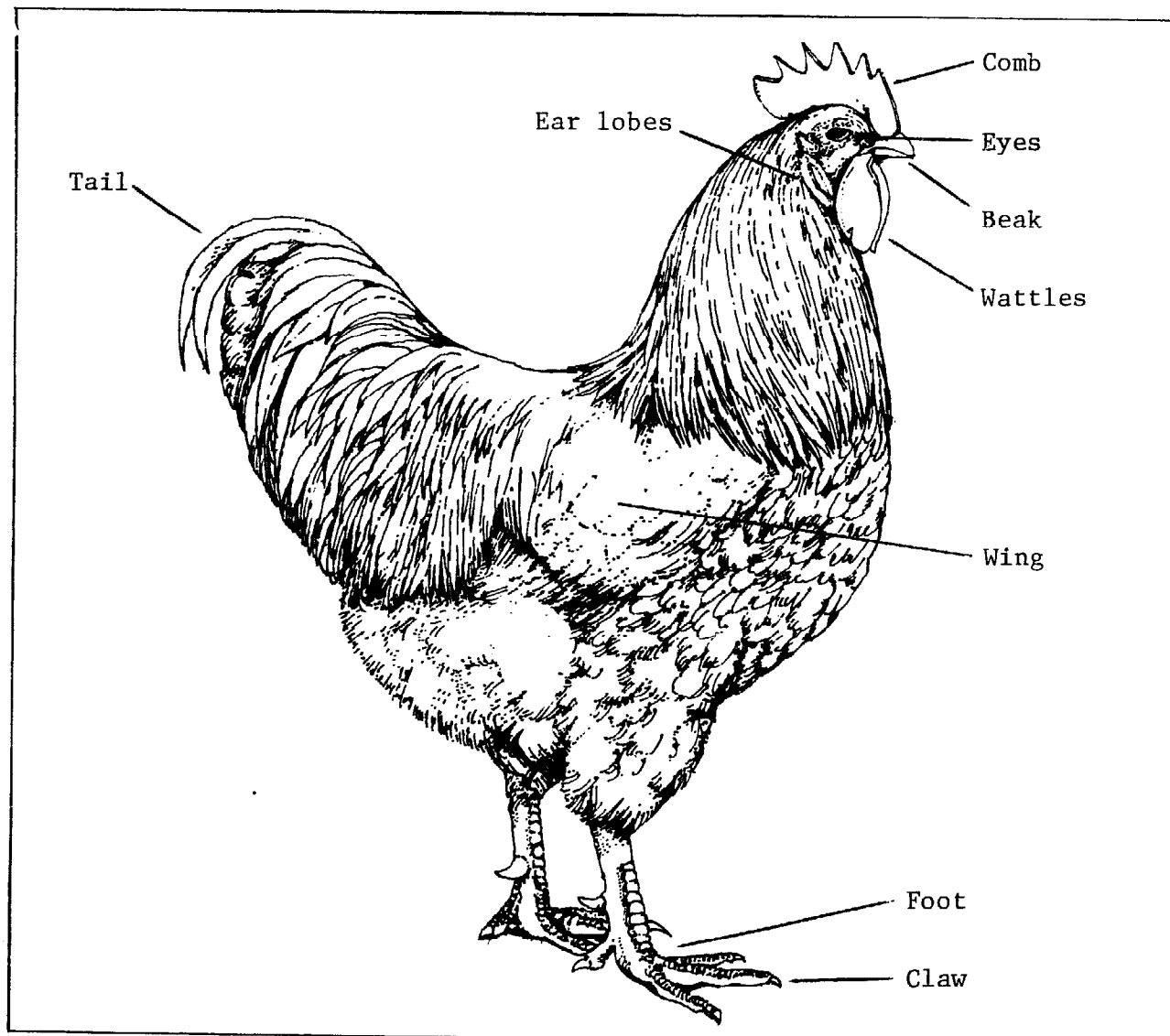

lieved that the comb and wattles of chickens serve to cool their blood.

- Ear lobes -- The ear lobes of chickens serve hearing and other ear functions.
- Eyes -- The eyeball of a chicken is stationary; thus, a chicken must move its head to vary the range of vision.
- Feathers -- Feathers provide insulation and buffer extremes of heat and cold.
- Wings -- Chickens cannot fly very well. They can flap their wings sufficiently to raise themselves about three meters (m) off the ground.
- Tail and tail feathers -- The tail is used for balance while walking and, in flying, as a rudder for up-and-down and side-to-side motion.
- Feet and claws -- In addition to walking, feet and claws are used in fighting (for protection) and in finding food.

There are several differences between male and female chickens that should help in identification. These are:

- Size -- The male will grow taller and usually weighs between 0.5 and 1 kg (1 to 2 pounds) more than females of the same age upon reaching maturity. A male of one breed may weigh less than the

female of another breed.

This greater size is not apparent until the chicken attains four weeks of age. At one day old there is no difference at all between male and female chicks.

- Comb and spurs -- The comb of the male will become much larger than the comb of a female. On the female, spurs hardly develop at all when compared to the male.
- Vocal expressions -- Everyone knows that a rooster crows while a hen doesn't. What is not generally known is that roosters crow intermittently all day long, not just in the morning.
- Feathers -- Adult males have distinguishably different feathers from those of adult females. The most distinguishable are the tail feathers which are long and stringy on the male.

Usually male chickens of improved layer breeds are destroyed within a day or two after they are taken from the incubator because it is uneconomical to raise them for meat. In the case of improved meat breeds, both female and male are of economic value and are raised.

## Internal Anatomy of Chickens

Although it is not expected that you will become an expert, it will be useful for you to understand the anatomy and functions of different organs of chickens. Chickens do not have stomachs like other animals, but have a different means of food storage and digestion. First the food enters the beak (mouth) and goes halfway down the esophagus (throat) to a storage area called a crop where it is moistened and thus softened. Food then continues down the remainder of the esophagus and enters what is called the proventriculus, or true stomach. The proventriculus secretes digestive juices (enzymes and acids), and is directly attached to the gizzard which grinds food up into smaller pieces. Food leaving the gizzard enters the small intestine where nutrients are picked up by blood vessels and circulated throughout the chicken's body. Food particles then move into the large intestine, which has two "blind" or dead end attachments called ceca. (The

functions of the ceca are not understood fully.) After digestion in both intestines, the waste materials including both urine and stool are excreted through one opening called the vent. The excreted material is called feces.

The heart and lungs of a chicken function in the same way as those of most other animals. Air enters through the nostrils then goes down a tube called the trachea, located right beside the esophagus. Both tubes are located on the under side of the neck when the chicken is standing. The entrance point to this air tube is located at the back of the mouth and is called the larynx. The trachea looks like a thin plastic tube with rings around it. This ends at a Y-shaped junction and two bronchial tubes lead off to the right and left lungs. The trachea and bronchial tubes look like semi-transparent plastic tubes. The lungs are segmented and located between the rib bones leading from either side of the back bones of the chicken. Going further back towards the tail, you find the reproductive system, then, closest

to the tail, there are pockets in a larger bone which contain the kidneys. If normal, the kidneys are brownish red in color.

If you open the chicken lying on its back, the first thing you will see is the liver which is divided into two parts, just forward of the soft skin above the vent. There is often yellow or white fat between the skin and the liver. The normal liver is the same or slightly lighter color than the typical animal liver found in a marketplace. Under and forward of the liver you will find a small sac of green fluid. This is the gall bladder. After you pick up the liver and the intestines, you will find a small ball-shaped organ, the spleen, above the kidneys. The spleen is lighter in color than the kidneys.

In the female adult chicken, if it is laying eggs, you will find to the rear of the lungs and along the back the ovary, which consists of a mass of egg yolks ranging in size from microscopic to almost an inch in size. The smaller ones will be opaque. Egg yolks enter a tube through what is called the funnel. The funnel

leads to the oviduct through which the yolk passes and in which the egg white, then the shell, is formed, a process which takes about 24 hours. Upon mating with a rooster, sperm passes through the oviduct system in the opposite direction. Fertilization takes place at the ovary end. Sperm may stay viable for up to 4 weeks and are stored in the oviduct. The best way to learn about the chicken is to go to the market place and buy a chicken. If you are not willing to kill a chicken yourself, have it killed. Later on, you'll get used to killing chickens if you work with them very much. If there are no chickens in the market, buy one from a farmer. Watch the way he kills it. You may want to use the same method used by the farmer. In any case, take it home and try to find all the parts of the chicken described above. Do this several times, until you have learned the parts. If possible, go to a veterinarian for a test, using a male and a female chicken. (Don't go to the veterinarian until you have tried on your own several times. If you go too early, all you will do is memorize

and forget what is shown to you.)

## Handling Live Chickens

Thus far, you have learned some general information about the chickens. Now it is time to begin learning to handle live chickens. The best way to learn is by experience, and the best chance to get this experience is when a farmer or local veterinary worker also is doing it. Find out if there are any poultry handling activities coming up in the near future. These activities may include the arrival of chicks from a hatchery, vaccinating, debeaking, moving chickens from one house to another and marketing. (You do not need to worry about these terms. They are explained later in the manual.) Some farmers, veterinarians and extension workers will not want you to be involved in different poultry handling activities: you will need to be understanding about their natural skepticism and concern.

Watch others handle chicks. When they come from a hatchery at day-old, they are usually in a cardboard box or bamboo basket. Pick up a chick with your hand over its back. Do not squeeze, as they are very delicate. Hold it as gently as you can without dropping it. Carefully examine the chick. Practice picking it up and setting it down gently. Hold its leg a little to one side and notice how delicate it is. Stretch the wing gently to the side and feel its bone structure. Hold a cup of water in one hand and the chick in the other. Using your thumb and index finger to keep the head of the chick still, practice dipping the beak of the chick in the water. Later on you will find this capability of holding a chick in one hand useful for vaccinations and giving its first drink of water.

To hold an adult chicken for examination, place your middle fingers between the legs with the head of the chicken facing behind you at your side. The breast of the chicken will rest on your arm. Stroke the chicken's back until it is calm. Once you are accustomed to this, extend your arm

out in front of you to get a good look at the chicken's head, neck and wings. When examining layers to determine the differences between a layer and nonlayer of eggs, keep the chicken at your side.

Handle a rooster. Look it over carefully. Find other roosters and compare their appearances. In particular, notice the spurs, comb and state of health. Feel the breast of several roosters. One may be very thin and all you will feel is a breast bone. Others may be fatter, healthier, with breast meat.

Handle several hens. Ask a farmer to show you one that laid several eggs during the past week. Ask also for some which have not laid any eggs for a long time. Compare the chickens for differences, especially the softness of the skin below the vent, the distance between the bones on either side of the vent (called the keel bones) and the distance between the breast bones and the keel bones. Measure how many fingers you can fit between the keel bones when your fingers are side-by-side.

When removing older chickens from crates or cages, catch them by their legs and, holding the head in the free hand, take them out head first. If you take them out feet first, their wings may be caught in the cage opening, resulting in injury to the bird.

Next, practice holding four or five chickens in one hand at the same time. Do this by adding one after another, holding both legs between your fingers and with the heads of the chickens straight down toward the floor.

Practice handling and examining chickens of all ages. Notice any differences in weight, feather development, comb size and so on. If possible, help in vaccinating, de-beaking, moving or any other poultry handling opportunity that comes up. In all cases, be sure you take a bath and wear freshly washed clothes before handling chickens. To avoid any chance of transmitting disease into a poultry flock, take a bath and change clothes between visits to different farmers as well. Carry spare shoes for entry into a poultry

house. Some farmers will not think this is so important and if this is the case you probably cannot advise them in this regard.

If you have the chance to move chickens into or out of carrying crates, the head always goes in first, and usually out last. As a rule-of-thumb, the air space around, below and above a chicken in a crate should equal the space occupied by the chicken itself. In hot climates, the air space must be greater. The larger the chicken, the greater the provision for ventilation must be when moving chickens.

## Catching Chickens

There are several methods of catching older chickens. One is to use a catching hook:

To use the hook, quietly approach the target chicken from behind and, when close enough, rapidly hook the chicken's leg and pull steadily toward you.

Another way is to corral the chickens using a framed wire mesh or bamboo box with hinged corners on three sides with the fourth side open. This box can be used for catching large numbers of chickens, but at least two people are needed for this method. Before starting, remove all feeders, waterers and other equipment from the pen, leaving only the chickens and the litter. Next, corral the chickens as you move the opened box (or catching frame) across the floor. When a number of chickens are inside, close the box. Then you can easily reach in and pick up a chicken.

Now that you know what a chicken looks like inside and out, tastes like and feels like, you are ready to read the rest of this manual and use the information that is most appropriate to your conditions.

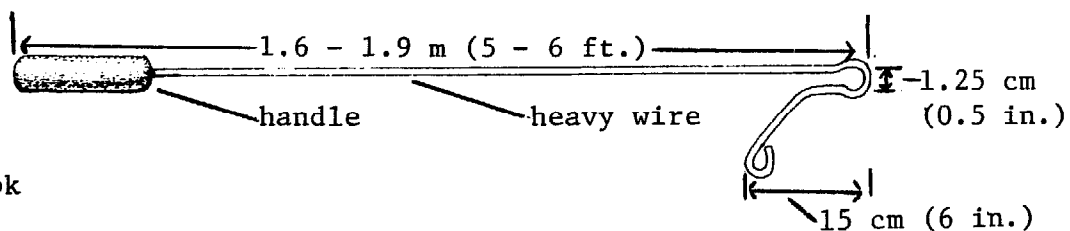

Catching Hook



## 4. Working with Country Chickens

The country hen is an admirable creature. Through the thousands of years she has lived among humans, she has developed into a self-reliant, disease-resistant, parasite-tolerant scavenger who can survive on almost any kind of vegetable and animal matter that comes her way. She can evade predators, knows where to shelter when it rains and how to find safe roosts at night. Her eggs, though small, are tasty, and her meat, though tough, is delicious.

For good reason, the country hen is a universal symbol of motherhood. She is eager to set and hatch her eggs, turning them as needed and staying on them continually for three weeks except for very brief forays for food and water. She is so good a mother that she often is used to hatch and care for the young of ducks and other species of poultry.

The one thing she can't do is produce eggs and meat as well as the improved breeds can.

The country hen is geared to produce just enough eggs to assure the survival of her species. This usually means about 40 to 50 eggs a year, many of which are lost to predators, heat, cold, dampness, breakage and human consumption. If farmers give her good care she may double her egg production, but she never will reach the levels attained by the new breeds.

### Why Work With Country Chickens?

Using the country chicken may be the only choice in some areas. Local farmers may not be able to

afford the high per-bird investment that new breeds require. The village may be too remote for the transport of live chicks from a commercial breeder. Vaccines, medications and the balanced feeds needed by the improved breeds may not be available locally. Or, farmers just may not want to work with commercial breeds that require so much effort for them to survive and produce.

If this is your situation, don't be discouraged. There are many things that can be done to improve country chicken production. However, you must first consider:

Farmers' attitudes and desires

Unless you have the active interest of at least one farmer who wants to improve the flock and is willing to work with you on identifying problems, setting priorities and developing an improvement plan, you won't get very far. Never cast yourself in the role of an expert outsider presenting an undebatable plan.

The effect on the whole area

When country chickens run free,

they are part of a large, single system. Individual flocks may "belong" to a particular farmer, but they interact with other chickens and thus influence other farmers' outcomes. For example, if a farmer vaccinates against a disease, it might result in a disease outbreak among other chickens. If some farmers protect their chickens from rats and other predators, the remaining farmers will face increased predator problems. Most likely all the chickens in the village compete for the same food sources. If some farmers increase the size of their flocks, will there be enough food?

The market In most cases, country flocks are improved to benefit family consumption. Is there room for expansion beyond this?

# Production Potential

Keep in mind the limits of the country chicken. Do not encourage farmers to spend more money on their flocks than they will receive in benefits from home consumption or sales. You can assume that the average country hen has a production potential of 80 eggs per year. This does not mean that a particular, small flock of five or so hens will lay 80 eggs each a year under good management. Individuals or small groups may have a higher or lower potential than average. If there are 100 or more country hens in the area, however, you can use 80 eggs per hen as a goal until your experience suggests a different figure.

The smaller the flock size, the more you must try to reduce the cost of inputs to be on the safe side.

Some examples are:

- Use locally available inputs, especially free ones such as harvesting and food processing by-products.
- Use government programs, if available, such as veterinary services, vaccinations, loans and grants, breed upgrading help, lower-cost feed, or feed concentrates.

# Gathering Information

The best source of information on the current country chicken situation is, of course, the farmers in your area. Local officials and your own observations will be helpful as well. For your area as a whole, you will want to know such things as the number of farmers with chickens, the total number of chickens, the average number per farmer, the types of management systems they use and the problems that concern them. This is best discovered by talking to as many individuals as you can, keeping in mind such questions as:

- Why does the farmer keep chickens?
- How many years has the farmer kept chickens? Did previous generations of the family

keep chickens as well?

- How many eggs and chickens does the family eat each year? How many do they give away or sell?
- What are the major causes of egg and chicken losses? What protection is given?
- At what time of the year does the farmer think that having eggs and meat available is most desirable, and why? (For example, there is usually a heavy demand for eggs and meat at the end of a religious fasting period in countries with large Islamic populations, and a similar demand for meat for Christmas celebrations in places with large Christian populations.) In addition to times of general demand, farmers often can benefit by contracting with local leaders for meeting special demands for local celebrations, weddings, and so on.
- If eggs and meat are relatively expensive food items, when will consumers have the most purchasing power? After harvest season? Will the fishing season have an impact on egg or meat demand?
- When does the farmer or flock hatch chicks, and do they reach production peaks at the time of the year when eggs and meat are most desired? If not, why not?
- How many chicks were last hatched, how old are they, and how many are still alive? Are these the usual totals for a chicken generation, and if not, why not?
- Which management techniques does the farmer use and why?
- If the farmer supplements the flock's diet, what foods are used and why?
- Has the farmer had technical advice? If so, who gave it and how?
- Did the farmer follow previous recommendations? If not, why not?
- Who in the family traditionally cares for the chickens (women, men, children)? Were they the ones who received previous technical advice?
- Are this farmer's responses similar to those of other farmers? If so, do they indicate area-wide problems that need attention first?

Now that you have this information, you should have a broad understanding of poultry in your area. You have made contact with a number of different farmers, and differences in the way they care for their chickens should be evident. Also, the better farmers may be good future contacts for improved ideas which are

appropriate locally. Now you can look at possible areas where you might focus poultry development efforts.

## Possible Management Improvements

As often said, almost any operation can be improved. Some of the techniques that can be used with country chickens follow, listed approximately by priority. As you and an individual farmer discuss them, the two of you together can begin setting goals and form a plan to meet them.

Study this manual's sections on working with improved breeds. Some of the recommended management practices and equipment can be adapted for country chickens.

### Shelter at Night

The country chicken is an independent creature that does not adapt well to a contained system, but it does need nighttime shelter. Shelter overnight probably is the most important possible improvement because it protects the chicks from nocturnal attacks of dogs, cats, rats, owls and other predators. Even adult chickens can be lost to predators.

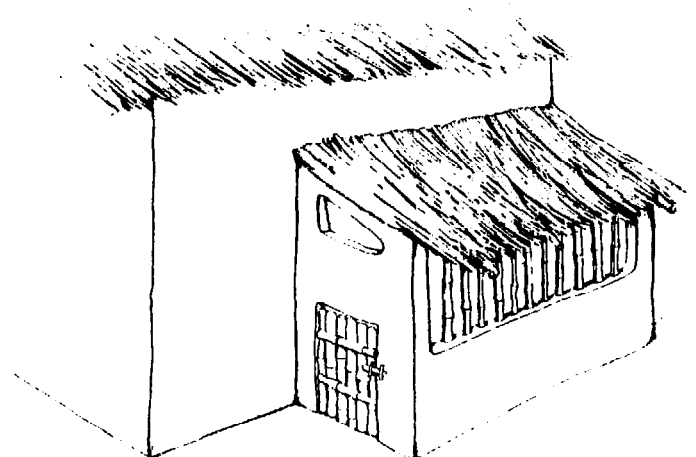

Night Shelter

## Shelter for Chicks

Chicks should be protected constantly until they are at least four weeks old. If a brooder (see Chapter 5, p. 58) or another heat source, such as a box or pen near a kitchen fire, is available, chicks should be separated from the hen about one week after hatching. The sooner this is done, the sooner the hen will lay eggs again.

## Nests

Set a box or basket lined with straw or other suitable litter in a dark place where the hen can be trained to lay her eggs. To train a hen, introduce her to the nest each morning about the time she usually lays. Put an egg in the nest each morning, using a new one every few days so that it doesn't spoil. If an egg is already in the nest, the hen probably will decide it is a safe place to lay another. Eggs should be collected every day. A country hen will want to sit on her eggs if they accumulate. If she

does, she will become broody and stop laying for six to eight weeks or even longer.

## Care of Chicks

Chicks do not need feed or water for the first 24 hours after hatching because part of the yolk remains inside them. Give them water, but be sure they cannot get into the container and drown. Use whatever materials and foods you have available to come as close to modern management (see Chapter 5, p. 55) as you can. An adult chicken's production potential depends heavily on the quality of care it receives during early growth stages.

## Improved Feed

It usually is uneconomical to feed a fully balanced ration to country chickens; coming as close as possible to ideal nutrition with available foods can be a challenge. The main considerations are:

- Vitamins -- Feed fresh or dehydrated greens -- carrot tops, weeds, over-ripe fruits and vegetables, etc. They are

rich in vitamins and contain some minerals as well.

- Protein -- The country chicken's diet rarely includes enough protein. Use meat and fish scraps (not rancid), white ants (termites), beans that people won't eat, insects that have been attracted and killed by a kerosene lantern and so on. Give priority to chicks and laying hens.
- Carbohydrates -- Energy is supplied by such foods as broken rice, pressed coconut meat, stale bread and other scraps.

## Health Care

Keep feeders and waterers clean. The shelter should be dry and clean also. Remove old litter and replace it with clean litter every three or four months. Compost the old litter or use it for making methane gas. Follow local recommendations for vaccinations. Use coccidiostats (see Chapter 7, p. 123) when possible, mixed in the water supply as recommended by the manufacturer. However, since country chickens are free to roam, use of coccidiostats in the water may not be of any use if other water sources are available. Treat

for worms when the chickens are four months old and every four months thereafter.

## Male Chickens

Surplus males waste feed. Sell or eat them when they are eight to ten weeks old. Always keep two roosters in country chicken operations for breeding purposes. Even with small flocks, keep a second rooster in case one dies, unless replacements can be obtained easily and inexpensively.

## Upgrading the Flock

Country flocks can be improved or upgraded by introducing roosters from improved breeds. In most cases the objective of this type of upgrading is to increase egg production. Thus, roosters from improved egg breeds are crossed with the country females. Do not attempt to improve both egg and meat production at the

potential of 130 to 150 eggs  
a year.

The more generations that are upgraded, the higher the potential. However, each generation's potential will increase at a slower rate, and they will need more intensive care and balanced feeds. If an upgraded flock mates among itself, potential production eventually will fall to the levels obtained before upgrading.

For upgrading meat production, simply use improved meat breed males in place of the egg breed, as above.

## **Farmer Assessments**

You may find it useful to prepare a simplified version of the Farmer Assessment Worksheets (see page 193). In your talks with a local farmer, the two of you can review such a worksheet, find the biggest gaps and plan how to fill them to improve production of country chickens.



# 5. Poultry Husbandry

This chapter deals with raising the improved breeds of chickens. Even if it were many times its present size, it could not offer all the information a dedicated farmer needs to provide the best care for the new breeds. Good use of other information resources and accumulation of local experience will help fill this gap.

If farmers are interested in trying the new breeds, or if they are raising them already and want to improve their operations, this chapter will provide them with some essentials to consider. The most important are:

Individual interest and commitment, In raising any livestock, there is no substitute for tender loving care. To do well with the new breeds of chickens,

a farmer must understand their needs, be ready to provide the daily attention they require, and understand that small details may mean the difference between success and failure. Management system. For reasons discussed later, this manual recommends using a fully contained system for the new breeds. Local considerations may influence this decision, but in general a well-run, fully contained system has the highest profit potential. This will mean that the birds completely rely on the farmer for all of their needs. Eggs or meat. It is best to concentrate on producing either eggs or meat, not both. Which will be the main product depends on the local market and the types

of breeds available. Some families, fully occupied with crop production during certain seasons, may find that an eight-to ten-week cycle of raising meat chickens fits their time available off-season.

## Breed Source

Far too many breeds and breed combinations exist throughout the world today for this manual to attempt to discuss them in any detail. The number of new breeds available in a developing country usually is limited to a very few. Chicks can be transported from other countries by air, but that is expensive and delays or other problems along the way can kill them.

If people in your area have worked with improved breeds, their history will be helpful in selecting a breed. If no one nearby has had such experience, you can try to find

successful farmers in other areas. Try to pick areas that are as similar to yours as possible in such features as social structure, climate, altitude and water and feed availability.

If you cannot get advice from experienced farmers, you will have to rely on the recommendations of commercial breeders or government breeding farms. Know as much as you can about your area's characteristics before you talk to breeders. Chicks from the best producing breeds probably will have the highest prices, but this is a very small part of your total costs--it usually is unwise to try to save money here. All things being equal, the most desirable breed is the one that lays the most eggs or produces the most meat per unit of feed. Other considerations are the breed's hardiness, adaptability to your area and selected management system and, most important, its acceptability among local farmers.

# Layer Breeds

The basic decision is between breeds that lay white eggs and those that lay brown ones. There is no nutritional difference between white and brown eggs. However, people in your area may have a strong preference for one color or the other, and this should be considered. Good layers usually begin producing when they are 21 weeks old and continue for 12 months, laying about 250 eggs during that time.

## White Eggs

The most popular white-egg breed is the White Leghorn. It is smaller than other breeds and produces the most eggs per unit of feed eaten; thus, it has a higher profit potential. Generally, the best producer is a hybrid White Leghorn, but special breeds or crosses may have been developed in your area to meet local conditions.

Distinguishing features -- White feathers and ear lobes; adult females weigh about 2 kg (4.4 lbs.); males weigh about 2.7 kg (6 lbs.). Not all white-egg layers have white ear lobes. White Leghorns are known to be quite nervous and flighty. With proper care, however, they are excellent egg producers.

## Brown Eggs

Rhode Island Reds and New Hampshires are two popular brown-egg breeds, but there are many others as well. These breeds are heavier than

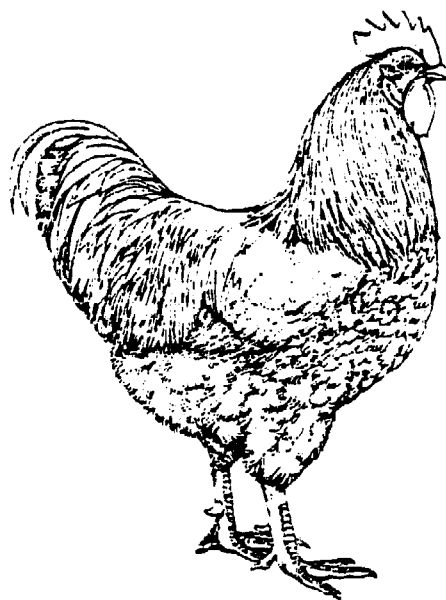

Male Rhode Island Red

White Leghorns. Some of them will lay as many eggs as White Leghorns, but will eat more feed per egg produced.

Distinguishing features -- Eggs vary in color from light beige to dark brown; ear lobes are red; feathers vary from almost white to red, brown, black or combinations; adult females weigh about 3 kg (6-1/2 lbs.); males weigh about 3.6 kg (8 lbs.). Some of the newer crosses weigh much less at maturity.

## Meat Breeds

A popular improved meat breed is a cross of a White Rock (a heavy breed) with another medium-weight breed, such as a Cornish or sometimes another White Rock. Present-day meat strains are known as "synthetic breeds" and are the result of crosses which may include White

Rocks, Cornish, Barred Rocks and other breeds. Mature adult females weigh about 3.6 kg (8 lbs.); males weigh about 4.5 kg (10 lbs.). They should be kept only until they are about eight to twelve weeks old when females weigh about 1.8 kg (4 lbs.), and males weigh about 2.3 kg (5 lbs.). In ten weeks these breeds reach almost the same weight as egg breeds reach in 20 weeks. Meat breeds also have more meat per unit of body weight than egg breeds. Some breeds with dark feathers also have dark skins -- a feature that many consumers don't like. If no meat breeds are available in your area, it might be economical to use males from the heavier brown-egg breeds for meat production.

## Dual-Purpose Breeds

Generally, these breeds are used to produce eggs, and the meat produced by them is a secondary consideration. If you are concentrating

on producing eggs, evaluate these breeds as you would layer breeds. If it is meat that you want, the choice will be more difficult, because it will be expensive to keep poor-laying hens to maintain the flock. When the specialized meat and egg breeds are available, it almost always is wiser to select one of them.

## Starting a New Flock

### Fertilized Eggs

Obtain eggs from a neighbor or commercial source, or use eggs from a current flock. Be sure that the eggs are no more than seven to ten days old and have been kept cool continuously. They will be hatched either by a broody hen or an incubator (see below).

### Day-old Chicks

Most countries have commercial

hatcheries that supply day-old chicks. Chicks should be kept in warm and humid conditions while transported to the farmer. If possible, the people at the hatchery should vaccinate the chicks for Marek's and Newcastle diseases before shipment. Chicks should be from a Salmonella pullorum disease-free breeder source. Plan to have the chicks arrive at the best time of the year and when equipment and supplies for them are ready -- ordered chicks may take several months to arrive. Chicks may come in one of two ways:

- Straight-run, or unsexed -- Straight-run chicks are half males and half females. This is the way all chicks are sold except specialized layer breeds.
- Sexed -- An expert examines the chicks and disposes of most males. People who sex chickens are about 95 percent accurate, so expect a few cockerels in the flock.

If you cannot buy sexed chicks for a layer flock, unsexed chicks will do. With heavier breeds, males can be raised as meat birds. With smaller breeds, such as the White Leghorn, it is best to eliminate all males as soon as you can recognize them (anywhere from three to eight weeks, de-

pending on breed), unless you want to isolate and keep a few for breeding. Layers do not need roosters around to produce eggs; in fact, the presence of males may lower production.

### Started Pullets

Young hens (four to six months) who are about to or have already started laying are called started pullets. They will cost much more than day-old chicks, but they begin to produce as soon as they arrive, and the farmer saves the time and equipment needed to incubate eggs and/or raise the chicks to laying age. Started pullets should be examined very closely for parasites and signs of disease. Know as much as possible about the hatchery's management methods -- have the pullets been fed properly, vaccinated regularly and otherwise cared for well, and do they come from good stock?

Started pullets may come down with coccidiosis since the farm where they came from possibly had different prevalent strains of coccidia than your farm does.

Coccidia are present everywhere but the different strains are not distributed evenly -- and immunity to one strain does not guarantee immunity to the others.

## Hatching Chicks

To have more chicks you will need a rooster to fertilize the eggs. One rooster is enough for five to fifteen country hens. If you can obtain one, consider using an improved rooster to produce progeny with the disease resistance of the country chicken and some increase in egg or meat potential.

Three or four days after a healthy rooster is introduced, the eggs laid should be fertile if the rooster and hens are good breeders. Fertilized eggs for hatching can be kept cool in a clay pot as described in the marketing section of Chapter 9 (p. 160). Eggs can be kept in the pot up to five days. If refrigeration is available,

eggs can be kept up to ten days at 15.5° C (60° F). Use clean, fertile eggs from several hens if possible, because not all hens will produce fertile eggs. Eggs should be average size, normal shape and without cracks (see below).

Select or develop a broody hen. In general, hens from improved breeds won't do because broodiness has been bred out of them. Pullets (females less than a year old) often do not make as good mothers as older hens do. A broody hen ruffles her feathers, stays on her nest and will return to it quickly if taken off. She is not as docile as usual and will peck your hand if you try to move her or take her eggs. If no hens are broody when needed, you can try to develop one by setting three or four eating eggs on a nest in a small pen in a quiet location that is protected at night. Put a healthy hen (the fatter, the better) on the nest at dusk. Do this every evening until she becomes broody. If it takes more than three days, provide new eggs and eat the old ones. Always keep water and feed

in small containers just out of reach of the nest in the brooding pen.

When you have a broody hen, treat her and the nest for lice (see Chapter 7, p. 126). Set about 10 to 15 fertilized eggs under her; the number of eggs she can cover depends on her size. The sooner the eggs are set for hatching after laying, the better the hatch will be. You should expect seven or eight chicks from 10 to 15 eggs, half of them female and half male.

Keep the hen confined to the brooding pen day and night, allowing her out to eat and exercise at dawn and at 2 pm. for about 20 minutes each time. Do this at the same time every day throughout the incubation period. She will become accustomed to the routine and will be upset if it is changed. While she is out, clean any feces from the nest and provide fresh water. The water container should be attached to the side of the nest box so she can't tip it over. In very dry climates, it may help to sprinkle a little water on the litter under the eggs, but never on the eggs themselves.

In most cases, the hen will turn the eggs and keep them moist by herself.

Occasionally, a brood hen will refuse to leave the nest to eat.

In this case, carefully lift her straight up off the eggs, making sure she doesn't have any tucked between her wings and body, and put her out. Let or put her back 20 minutes later.

On the 7th day of incubation for white eggs (10th day for brown eggs) you can use a candle to test eggs for fertility while the hen is out (see p. 54). Remember that there may be a delicate embryo inside, so handle eggs carefully. Remove all eggs without embryos, and those that have cracked shells or malformations.

On the 21st day of incubation, chicks should begin to hatch. Do not disturb the hen on the nest until the hatching period ends in the evening of that day. At that time, remove all unhatched eggs and broken shells. Dispose of weak chicks that can't free themselves from the shell; they never will do well. Provide clean litter for the nest. At this point chicks are ready for brooding.

## Incubation

For small numbers of eggs, one or more broody hens will do the job nicely. If there are no such hens around, or if you want to hatch more eggs, you will need to incubate the eggs artificially.

The main reason you will want to incubate eggs is to produce chicks which, when grown, will bring greater returns than chicks which could be obtained elsewhere. Other reasons could include incubation for educational purposes or unavailability of chicks from other sources when they are wanted. In order to succeed in your incubation you must have these basics:

- Selected clean, fertile eggs
- A source of heat
- A means of humidity control

More specifically, clean fertile eggs are from hens ideally between the ages of eight to eighteen months. These hens and, if possible, sisters, brothers, and parents of these hens, should have the characteristics desired in the



chicks. Since one hen may produce infertile eggs, use eggs from several hens. In order for eggs to be fertile, a rooster must have access to the hens for at least four days prior to collection of eggs for incubation. Again, the sisters, brothers, and parent generations of the rooster should have the desired characteristic. This can be a history of high egg production, rapid growth rates, resistance to disease or egg size.

The more factors you select for, the slower the progress will be. For the purpose of rapid progress and simplicity the following is recommended:

Step 1 -- Acquire roosters from an improved breed. Since most commercial breeders destroy the males of egg production flocks at the time of hatching, a commercial breeder is an ideal source of roosters. They will be one day old when you get them.

Step 2 -- If possible, find out from farmers which country chickens lay the most eggs.

Step 3 -- Cull out all males

in the village except those of improved breeds.

Step 4 -- Two weeks after the unwanted roosters have been removed from the village, begin saving eggs for hatching.

The cross of a country chicken which averages 60 eggs per year with an improved male whose sisters lay 250 eggs will bring excellent results. The daughters will lay 100 or more eggs if kept properly and will have nearly the same disease resistance of the country chickens. If kept under ideal conditions, they may lay 125 to 150 eggs.

## Egg Selection

Selection of good eggs for hatching is important to achieve good results. First priority should be given to eggs from hens which are between eight and eighteen months of age. This is because the size, interior and shell quality of eggs

from this age group is most likely to be good for hatching. Next, look at the shell closely. Eliminate any eggs which are cracked, dirty or misshapen. The best way to determine which are typically shaped is to lay 20 or so eggs on a table. Eliminate those which are nearly the shape of a round ball:

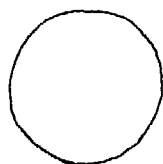

Eliminate those which are nearly the same size at both ends:

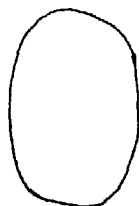

Eliminate those which have uneven shell structure:



What you have left should look like this:



It may have some specks of calcium deposits on the outside. This is all right if the size of the specks is smaller than the size of the period at the end of this sentence.

Bacteria on eggs will penetrate the egg shell within two to five hours after the egg is laid. Clean eggs can be sanitized by dipping them in a chlorine solution (500 parts chlorine per million parts of water) at 105° F. Do not use iron metal dipping baskets or containers because they will leave a rust residue on the eggs. Quarternary ammonia is quite effective as a disinfectant. Use 500 parts per million and dip eggs into a solution which is warmer than the eggs. In either case remove the eggs from the solution and do not handle them until they are dry.

# Incubator Management

A hen on a nest of eggs provides constant body heat and moisture, and turns the eggs frequently. Good artificial incubation mimics conditions in a nest.

A good incubator is an insulated

box with a regulatable heat source, a thermostat and a high-quality, easy-to-read thermometer that shows fractions of degrees accurately. Ideally, an incubator should have a small, glass window through which to read the thermometer, and a means of measuring and controlling humidity. A tray filled with water should be provided to generate the necessary humidity. The humidity should be

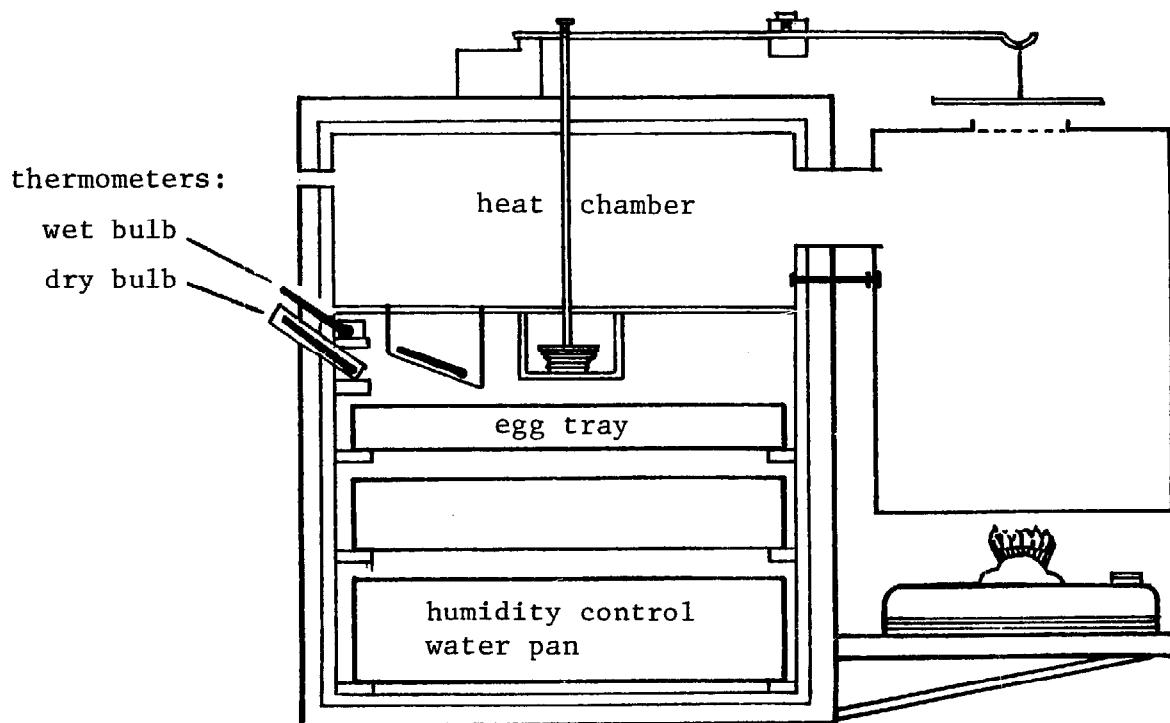

Kerosene-Heated Incubator

measured using a wet thermometer. A wet thermometer is simply an ordinary thermometer with the lower end of the thermometer inserted in water, or a thermometer placed above a source of water with a piece of cloth wrapped around the end of the thermometer and the bulb placed in the water. The incubator should have some means of adjustable ventilation as well.

Thoroughly clean the incubator with a strong disinfectant before use. Warning: do not use phenol, coal tar or pine tar for disinfecting an incubator. When heated, the residues release fumes that can kill embryos and chicks.

Once you have built or bought an incubator, run it empty for at least three days to practice regulating the temperature, keeping it at 37.8 - 38.3° C (100 - 101° F). Then place hatching eggs in the incubator.

The incubator should be in a well-ventilated but not drafty room. Once the internal temperature is 37.8 - 38.3° C (100 - 101° F), place the hatching eggs inside. Pencil an x on the upper side of the eggs.

Place a tray of water inside or fill the receptacles provided in the incubator, and keep them filled.

Turning the eggs prevents the embryo from sticking to the shell lining. The eggs should be turned at least once every eight hours, but shorter intervals are better. Turn the eggs an odd number of times each day so that the position of the eggs are alternated each long night interval. Remove the tray, closing the incubator door so no heat is lost. Use the pencilled x as a guide to rotate the eggs 180°. If the tray is square, rotate it a quarter turn each time you turn the eggs. This will help even out the effects of uneven temperatures on different sides of the incubator. Keep an accurate record of temperatures, time of each turning and which numbered side of the tray is in front.

On the 7th day of incubation for white eggs and on the 10th day for brown eggs, you can use a candler to test the eggs for fertility (see p. 54). When handling the eggs, remember that there may be a delicate embryo inside. If there is no embryo,

the egg may be edible provided that the air space in the egg (shown by the candler) is no larger than 9 millimeters (3/8 in.). The size of the air space will also help gauge the humidity in the incubator.

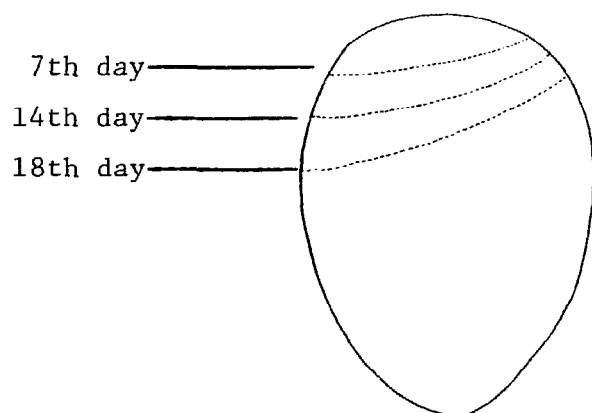

A candled egg showing normal air space during incubation.

If the air space is larger than shown, increase the water surface area available for evaporation; if smaller, decrease it.

Whether edible or not, remove all eggs without embryos or that have cracked shells. Increase the temperature to  $38.9^{\circ}\text{C}$  ( $102^{\circ}\text{F}$ ).

On the 18th day, double the water surface area available to increase humidity. Open all incubator

vents for maximum air circulation.

On the 19th day, and for the next three days, do not open the incubator except to check the temperature if there is no viewing window. Decrease the dry bulb temperature to about  $99^{\circ}\text{F}$ .

On the 21st day, the chicks will begin to hatch. Ideally, all chicks should have completed hatching exactly 21 days and 6 hours after setting in the incubator. Some chicks may not hatch until later in the day; these late chicks have been shown to be inferior genetically to those which hatch on time. After 21 days and 6 hours, you should open the incubator and remove all broken shells and unhatched or incompletely hatched eggs. If the incubator has more than one tray, distribute the chicks evenly in them and gradually reduce the temperature to  $35^{\circ}\text{C}$  ( $95^{\circ}\text{F}$ ). Remove any shell fragments stuck to the chicks. The chicks then are ready for brooding.

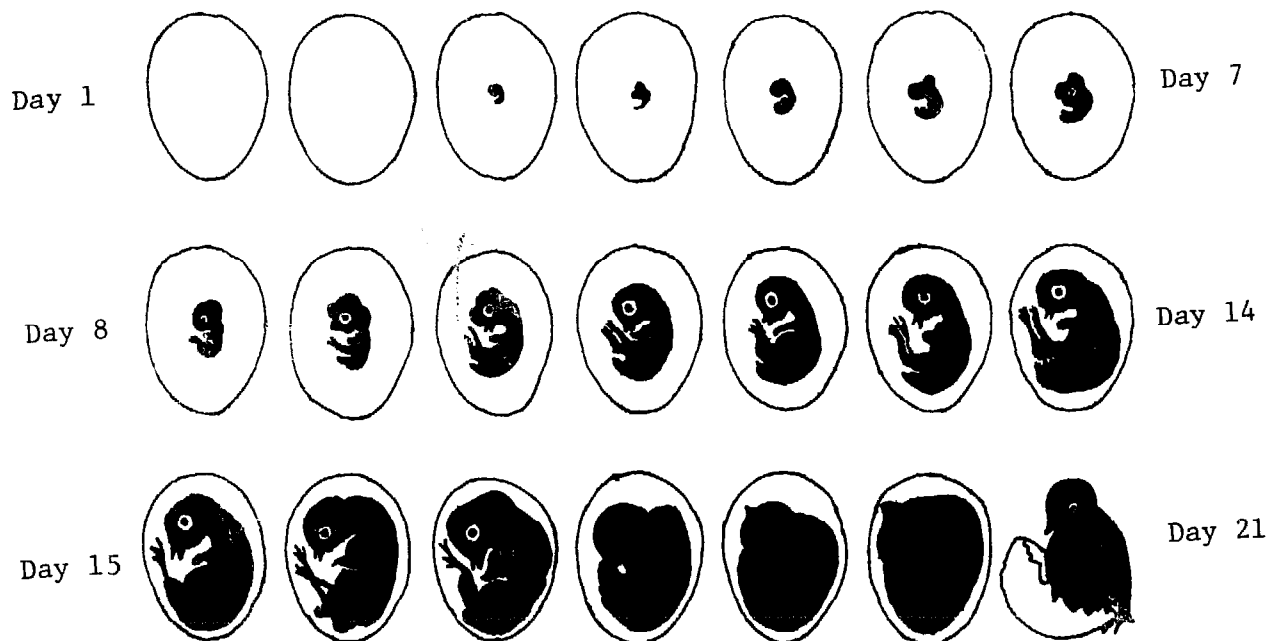

Twenty-one Days of Chick Development

## Candling Eggs

You can get a good view of an egg's interior by using a candler. A candler encloses a light source in a case or box with light shining through a circular hole 3 cm (1-1/8 in.) in diameter. Usually the light source is a 25-to 60-watt light bulb, but you can use a slide pro-

jector, a powerful flashlight (electric torch) or even a candle.

Use the candler in a darkened room. Turn the eggs quickly in the light so that the contents rotate, and look for:

- Embryos -- Thin blood vessels emerging from a dark red spot mean the egg has been fertilized and the chick has started developing.
- Cracked shells -- The candler will reveal cracks that can't be seen otherwise.

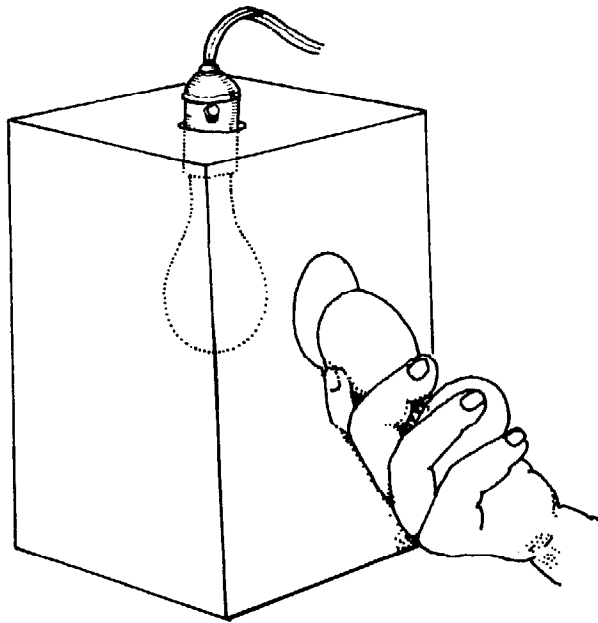

- Mold or rot -- Various colors on or in the egg, or its smell are signs of moldy or rotten eggs.

Always wash your hands before handling hatching eggs.

## Brooding Chicks

Small numbers of chicks can be given to a broody hen to care for. After she has set on a few eggs for at least two or three days, she should accept chicks. In the evening, slip a few chicks under her and, if she doesn't reject them, give her the rest and remove the eggs.

If there is no broody hen about, or if there are more than a dozen or so chicks, they will have to be brooded artificially. This is a critical time in their lives -- they must be kept warm and have water available at all times.

- Shape and movement of yolk -- Yolks noticeably out of their usual central position, stuck to their shell, uneven in color or of abnormal shape indicate poor quality eggs.
- Blood spots -- Although blood spots in eggs are harmless, many people find them unappetizing, so don't market eggs that contain them.
- Discolored whites -- Clouded or streaked whites reduce egg quality.
- Size of air cell -- An air cell more than 1.25 cm (1/2 in.) deep may indicate a bad egg.

## Preparation

If the house and equipment have been used for chickens before, older chickens should be removed at least a month before the chicks arrive. To avoid disease problems do not mix groups of chickens, especially chicks with older birds. Remove all feeders, waterers, nesting boxes, hoppers, roosts and other equipment from the house. Wash them, leaving no visible dirt. Clean them with a strong disinfectant, and rinse with fresh water. If possible, let them dry in the sun.

Remove all old litter from the house. Sweep walls, ceiling and floors to remove dirt and dust, then scrub with water and disinfectant. Make any necessary repairs to house and equipment. Spray the house with a safe insecticide if ticks, lice or mites have been a problem. Warning: Be very careful when using any type of insecticide. They can be dangerous to humans and chickens if used improperly. Check with local authorities to determine which insecticide to use, and follow

their directions carefully. On the following day, wash the walls and floor with a two percent solution of a mild disinfectant, if available; otherwise, use water. The house and equipment should have at least two days to dry out. Spread litter 5 to 10 cm (2 to 4 in.) deep on the floor. Depth of litter depends on its moisture-absorption capability (see below). If sawdust is used for litter material, cover it with paper during the first three days so the chicks don't eat it. Sawdust can cause problems in the digestive systems of young chicks. Replace the equipment and install and test the brooder at least 3 days before the chicks arrive.

Deep litter management -- Any organic material that absorbs moisture can be used for litter. Availability and cost, of course, must be considered. Possible litter materials, ranked approximately in absorption capacity, are:

- Peat moss -- Usually very expensive, if available at all.
- Chopped oat straw
- Softwood chips
- Hardwood chips



- Chopped rice straw
- Chopped wheat straw
- Softwood sawdust -- (only after four weeks of age)
- Hardwood sawdust -- (only after four weeks of age)
- Shredded maize (corn) stalks
- Rice hulls
- Groundnut (peanut) shells
- Shredded sugar cane stalks
- Dried pineapple waste
- Coffee hulls
- Ground maize (corn) cobs, shucks or husks -- may present mold problems
- Broadleaf leaves -- may present mold problems
- Sand -- use as a last resort

Watch for mold in litter since most good litter materials are also good mediums for mold due to their water retention characteristics. Any straw used should be well dried in the sun. Chopping the straw, although it may be difficult, increases its usefulness because it absorbs more moisture and can be turned more easily than unchopped straw.

**NOTE:** Do not use fine grass straw -- the chickens may eat it and some may be caught or bound in their crops.

The crop of a chicken that has eaten a substantial amount of straw will feel hard. More often, there will be only a few pieces of straw caught on the lower end of the crop. If the chicken then eats and drinks normally, feed and water will be clogged above the straw. The result is a large, soft and mushy crop. There is no practical cure for a crop-bound bird -- it is best to eat it.

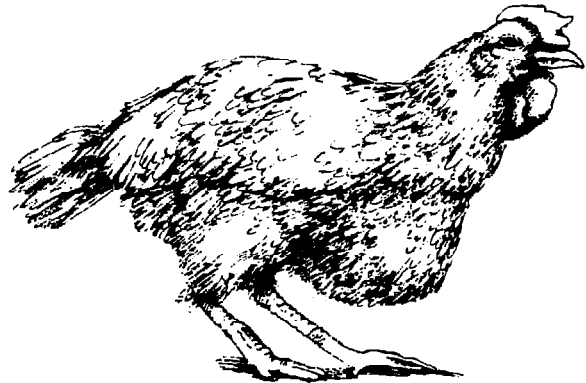

Crop-bound Chicken

Start with a litter depth of about 7.5 to 10 cm (3 to 4 in.), depending on its absorption capacity, and gradually increase it until it is about 15 to 20 cm (6 to 8 in.) deep at the end of a laying cycle. Don't let litter get packed down -- turn it

frequently. In humid climates, this should be done each day. Replace wet litter immediately. Add powdered lime to moist litter to help dry it. In dry litter, enough heat builds up to kill most bacteria, worms and fly larvae.

## Brooders

Brooders are used in place of brood hens to

keep chicks warm (the hover) and protect chicks from wandering. Either a kerosene lamp with

wire around it to keep chicks from crowding next to the hot glass or an electric light bulb can be used as a heat source. Charcoal stoves have to be tended too frequently to be practical.

Hover design -- A hover is a hood that retains and distributes heat evenly. It can be made of wood, woven bamboo or sheet metal, and either placed on legs or hung from beams. When using any heat source other than electricity, the hover should have a vent on top to allow fumes to escape.

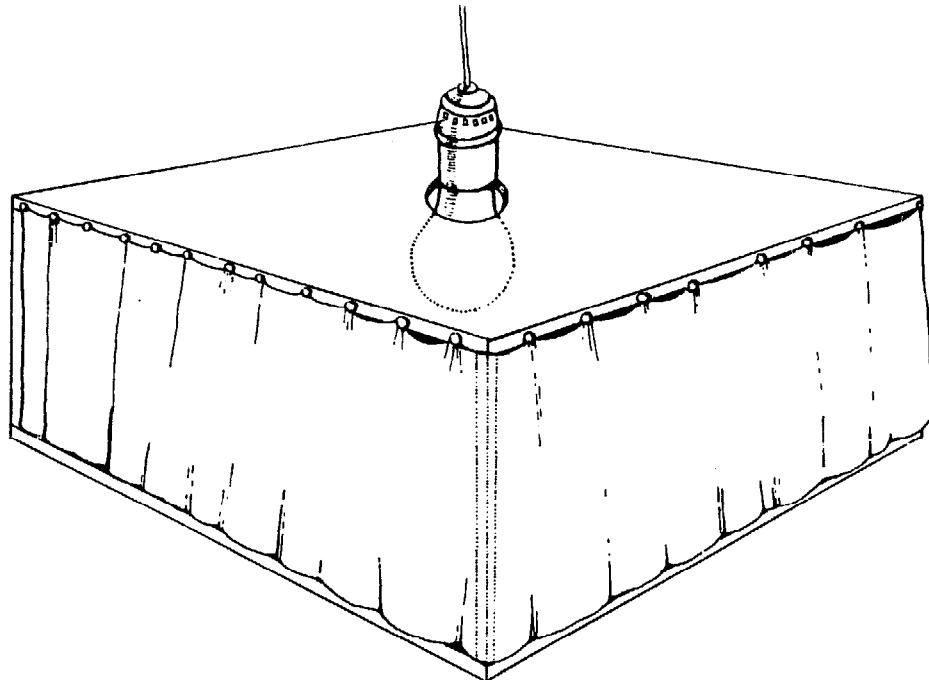

Light Bulb Brooder for about 50 Chicks

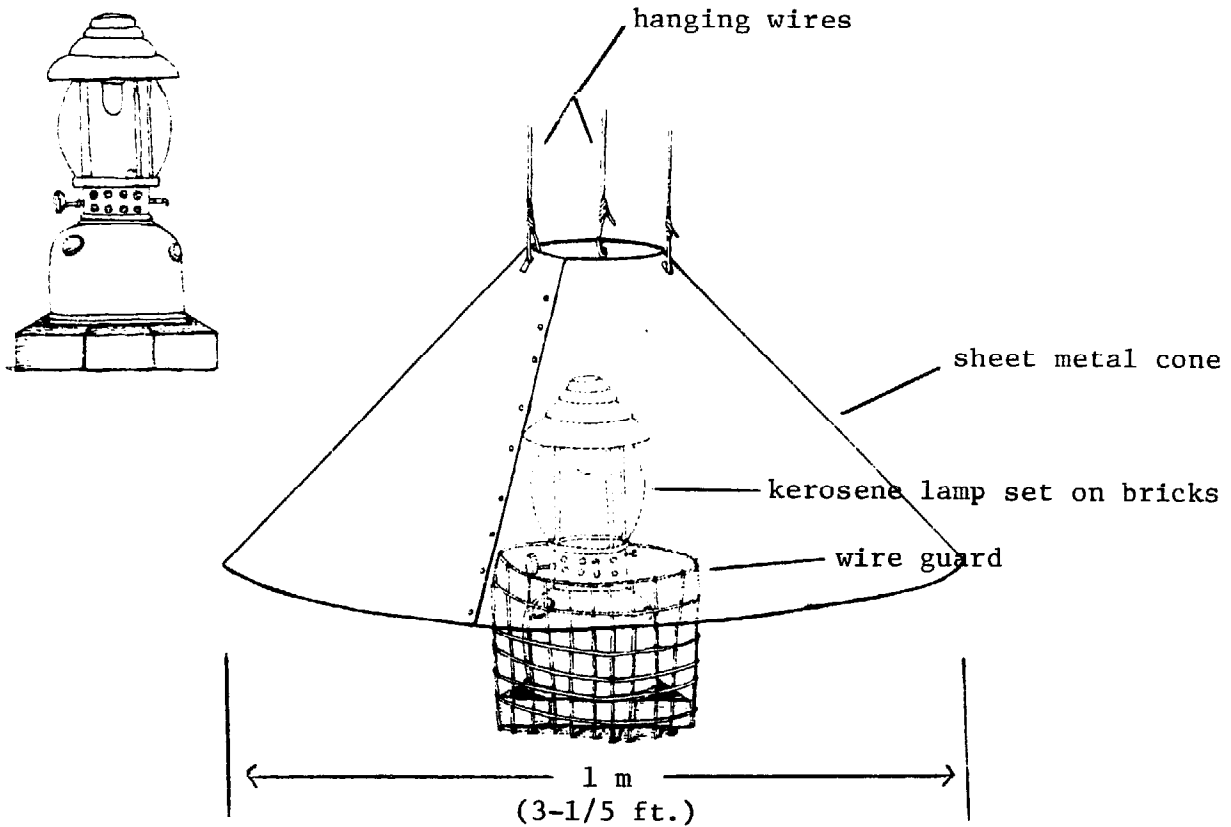

### Colony Brooder Suitable for 100 Chicks

Place litter beneath and distribute feeders and waterers evenly. Electric light bulbs (200 watts) can be substituted for kerosene lamps. (Note: brooders are a major cause of chicken house fires. Kerosene lamps, especially when near dry litter, must have a solid, level

base and careful handling is a must to avoid spilling kerosene.)

Other heat sources can include solar heat and wood chips. If solar heat is used, there must be a means of heat storage such as a water tank, sand or rocks. This storage is necessary for night warmth.

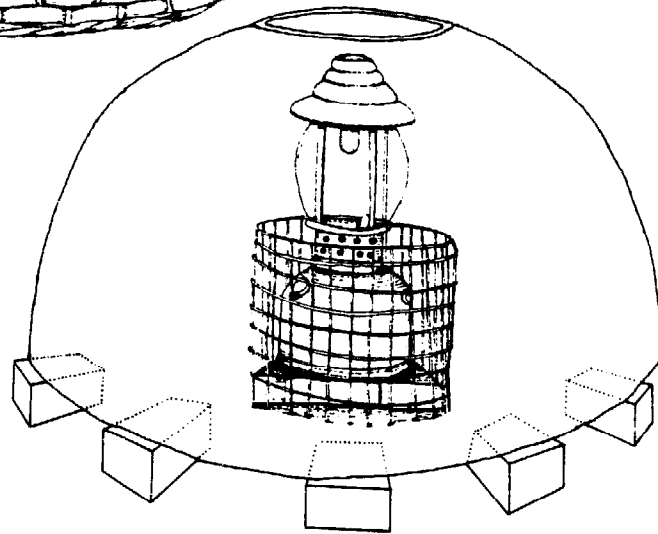
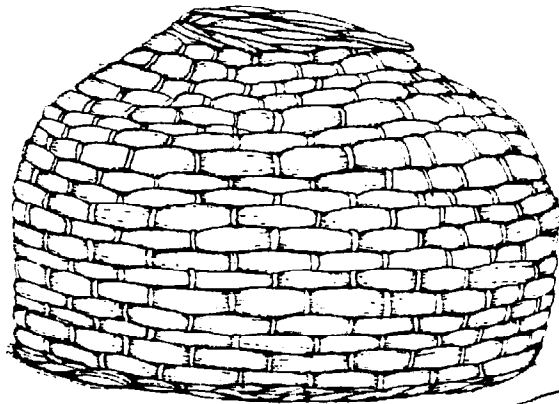

### Basket Brooders

Brooder guard -- A temporary fence outside the hover area is called a brooder or chick guard. A brooder guard keeps the chicks near the hover, but allows them to get away from excessive heat. It usually is made of solid material, such as cardboard, to reduce floor drafts. It has no corners where chicks can

pile up and smother. As the flock grows, the brooder guard should be expanded.

Brooder temperatures -- Read temperature 5 cm (2 in.) from the floor and 30 cm (1 ft.) from the heat source. Start the brooding at 35° C (95° F) for the first week, and reduce the temperature by 2.8° C

( 5° F) each successive week by adjusting the heat source or height of the hover.

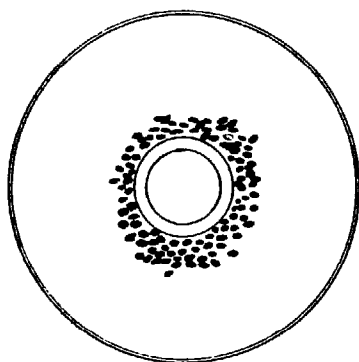

Too cold

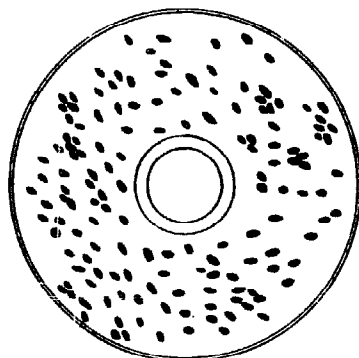

Just right

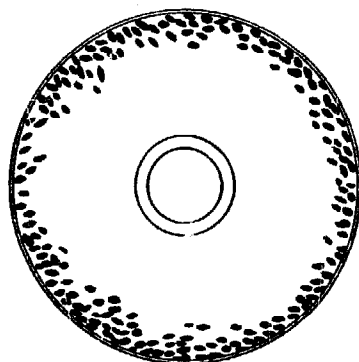

Too hot

Brooder Temperatures -- Top view of chicks distributed around brooder heat source.

Brooding feeders -- The first few days chicks will pick at anything and will not be able to tell a feeding area from the rest of the floor, so it is wise to have feed scattered over a large area. Put newspaper or cut cardboard boxes down on the floor and scatter feed on them to supplement the chick-size feeders.

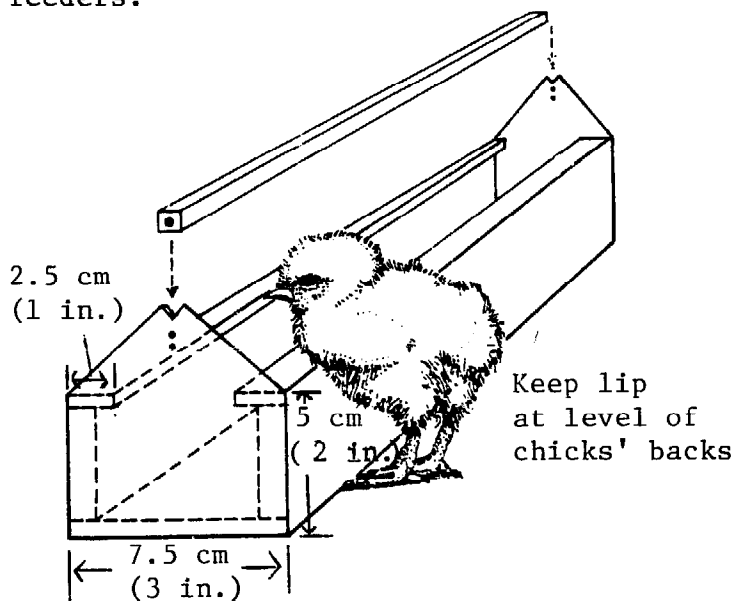

Chick-size Feeder

For their first three weeks, 100 chicks will need about 2.5 m (100 in.) of feeding space -- four feeders, each 33 cm (13 in.) long should be enough.

Brooding waterers -- For 100 chicks, use four waterers made of small clay jars or tin cans inverted in saucers or the bottoms of larger tin cans (see page 191). Increase number and size of waterers as the flock grows (see chart, page 100). Because chicks drown easily, openings in waterers must not be large enough to allow chicks to fall or be pushed into the water.

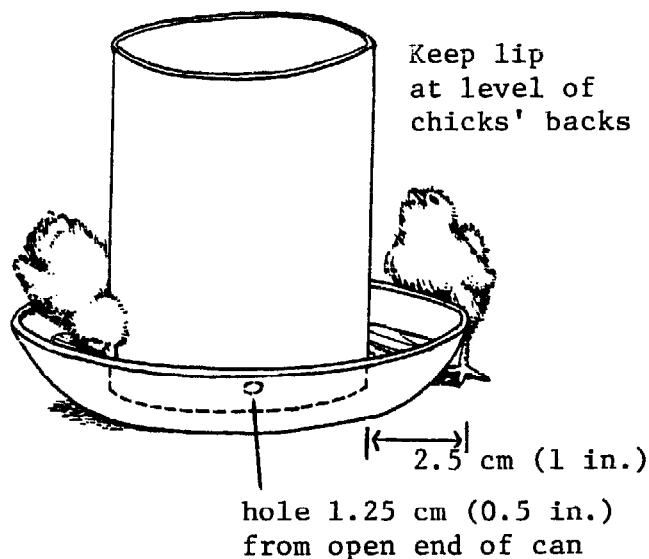

Chick-size Waterer

Place waterers on flat boards and keep the area around them dry.

Chickens need water every 15 to 20 minutes. They must have a con-

tinuous supply of fresh, clean water if they are to do well. Change the water at least once, and preferably twice, each day. Keep waterers as clean as possible and replace rusty ones.

Distribute waterers evenly throughout the house. During their first week or two, no chicks should be more than 1 m (3 ft.) from a waterer and not more than 3.5 m (10 ft.) thereafter.

Disease can start quickly when water is spilled on litter. Keep the area around waterers dry and clean. It is better to place the waterers on flat rocks, bricks or slatted or wired platforms than on litter. Remove and replace wet litter as soon as possible.

Placement of brooding equipment --

Distribute the equipment evenly under the hover to give all chicks a good chance to eat. Shift the position of waterers and feeders often to keep litter clean and dry.

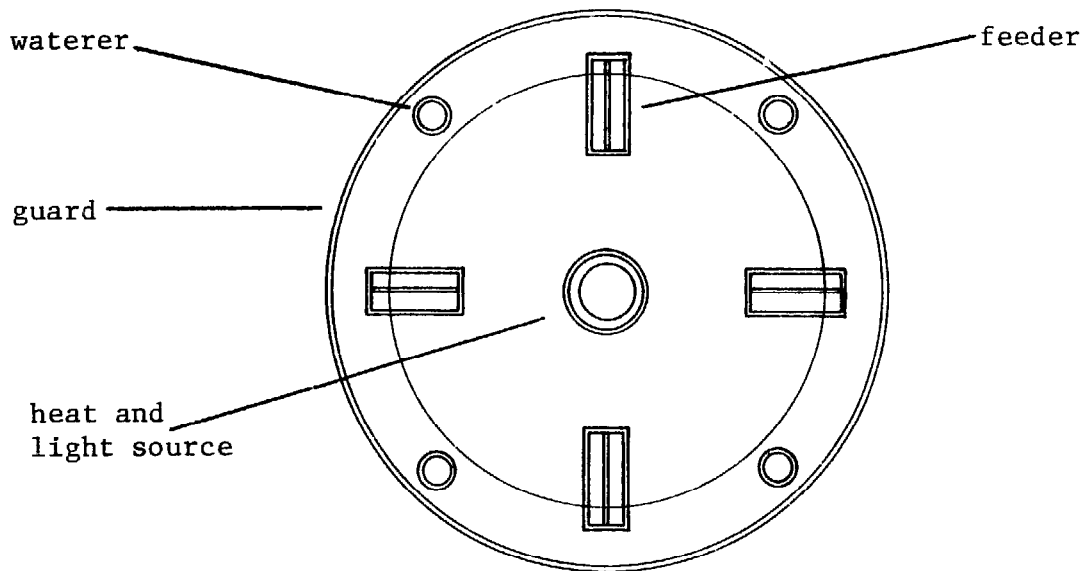

Layout of Brooding Equipment

## Brooding the Chicks

A few hours before the chicks arrive, put clean water in the waterers, completely fill the feeders and put some feed on the paper or cardboard. The temperature under the hover should be 35° C (95° F).

When the chicks arrive, count them and dip the beak of each one into a waterer to be sure that it gets a drink. Vaccinate them for Newcastle disease (see page 119) if this hasn't been done. (Note: Check with local authorities for

all vaccination recommendations and schedules. Before vaccinating chickens against any disease, get approval from the appropriate government ministry. If you vaccinate for a disease that is not present in your area using live serum, you may introduce that disease instead of protecting against it.) Watch the chicks for at least two hours. If any are obviously ill, remove them. The chicks' behavior will tell you whether the brooder temperature is correct. If they huddle close to the heat source, it is too cold; if they

crowd the brooder guard, it is too hot. Check the distribution of the chicks and see that they have feed and water often -- every three hours for the first 24 hours, including the night.

During the brooding stage, chicks will eat through the night because light is available continuously. They should never be without feed for more than 30 minutes at a time (the same is true for mature birds during daylight). The feed should contain a coccidiostat, if recommended by local authorities (see page 123).

Spend time every day just observing the flock. While they grow, see if they are all about the same size and are putting out feathers at about the same rate. If so, the chicks probably are from good stock, healthy and receiving good feed. Watch for inactive chicks -- one that stands still for more than ten minutes most likely is sick.

On the 3rd day, allow the chicks to finish the feed in the feeders. From then on, fill the feeders half full. If chicks are

eating well, remove the paper or cardboard.

For the rest of the chickens' lives, completely change their water at dawn and in the early afternoon, rinsing the waterers out as you do so. Chickens should have water available at all times.

On the 4th day, begin looking for signs of coccidiosis (see page 122). If there is a serious outbreak, take immediate action. Be alert for coccidiosis until the flock is at least 12 weeks old.

On the 6th day, be sure that there is grit in the feeders. From then on, always have grit available.

On the 7th day, fowl pox vaccinations may be recommended (see page 120). Decrease the temperature to  $31.1^{\circ}$  C ( $90^{\circ}$  F). Remove the brooder guard.

On the 14th day, lower the temperature to  $29.4^{\circ}$  C ( $85^{\circ}$  F).

On the 21st day, provide larger feeders (see chart, page 106). Lower the temperature to  $26.6^{\circ}$  C ( $80^{\circ}$  F).

On the 28th day, lower the temperature to  $23.9^{\circ}$  C ( $75^{\circ}$  F). If recommended by local authorities, vaccinate against Newcastle disease



and bronchitis.

On the 35th day, you may begin vaccinating for bronchitis and fowl cholera, if appropriate (see page 120). Place waterers on a slatted or wire mesh platform. Lower the temperature to 21.1° C (70° F). If nighttime temperatures do not fall below this, remove the brooder. Even in cold weather, you may remove the brooder a week later. Make sure that drinking water does not freeze.

## Meat Breed Management

Once meat birds have been vaccinated on the 35th day (see page 120), they may not need any more special care, as they should be sold by ten weeks of age. If they are kept beyond ten weeks, they probably will need larger feeders (see chart, page 106).

Watch the flock and treat for outbreaks of worms, coccidiosis, parasites and other health problems.

Remove any sick birds. If there are more than one or two, perform a post mortem examination (see page 128), or take the birds to a veterinarian or a laboratory for analysis.

## Layer Management

Layers should be kept in the same house or cage during their laying year. Moving them when they are laying may cause them to stop laying for several weeks. They need water and feed available continuously during daylight, and their calcium requirements are high. The figure shows a typical layer house equipment arrangement.

Layer management schedule -- On the 42nd day, vaccinate for fowl pox, if recommended by local authorities. On the 52nd day, vaccinate for Newcastle disease. On the 84th day, increase feed and water space (see chart, page 106). Begin lighting

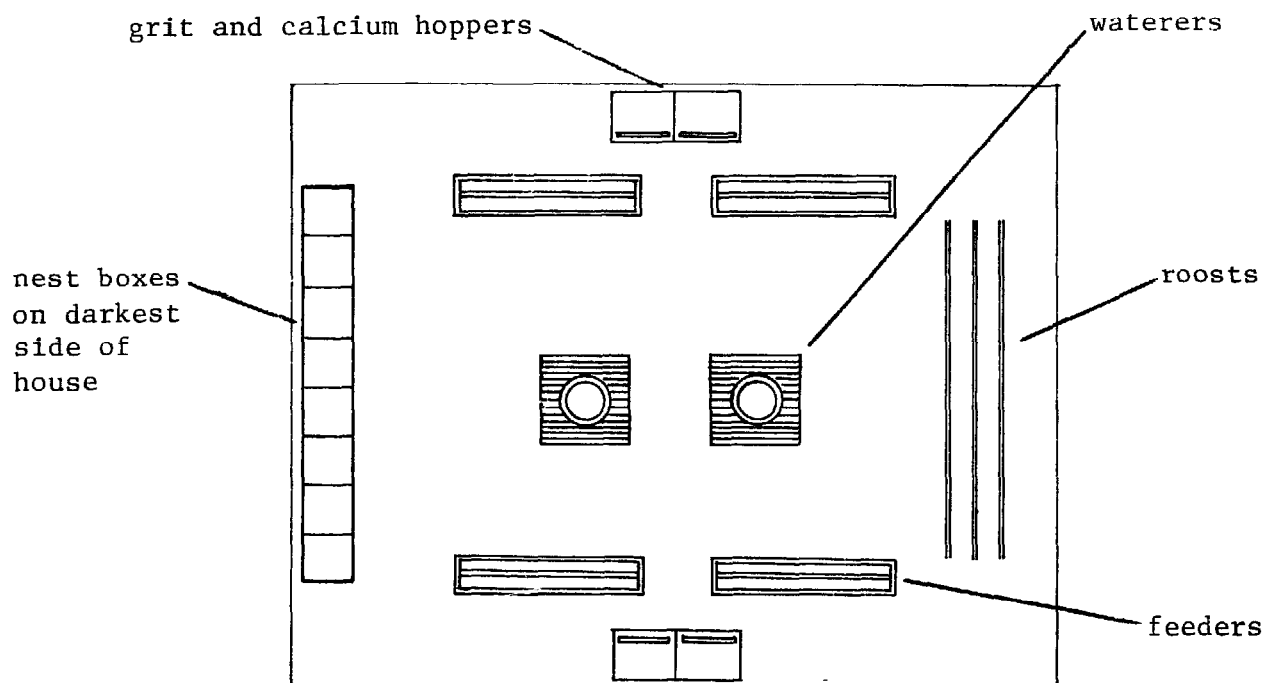

Layout of Layer House

program, if appropriate (see page 69).

In the 15th week, if you plan to use roosts, put them in the house.

In the 16th week, if dead or culled birds show signs of worms, begin medication.

In the 19th week, place nesting boxes in the house so the pullets get used to them before laying.

In the 20th week, change to a laying ration (see page 140). Cull all pullets that look sick. If

you are going to use cages, place hens in them this week. (One does not have to change to laying ration until 50% of the flock are laying. The main difference between a laying ration (fed to layers) and a growers ration (fed to growing birds) is the amount of calcium in it. Chickens should not be fed extra calcium until 50% of the flock start to lay.)

In the 21st week, white-egg breeds should begin laying. The chickens might start laying at 16 to

22 weeks of age if the lighting program is wrong.

Look for any eggs outside the nests. Hens found laying in other places should be introduced gently to a nest with an egg in it. Once hens begin laying, they should not be disturbed in any way.

In the 23rd or 24th week, brown-egg birds should begin to lay.

Egg production should peak at about 85 to 95 eggs per day per 100 hens and then fall gradually to about 55 to 70 eggs at the end of 12 months of laying.

Genetically improved layers today appear to molt (lose and replace feathers) throughout their adult lives rather than to lay eggs for a period, molt and start laying again. There are several factors which can influence how long a flock of layers will produce economically. These include breeder, egg and feed prices and environmental factors including general management, weather and seasonal considerations. Normally, layers are kept for 12 months of lay. In certain cases, where flock replacement costs are high,

it may be economical to keep them for another six months. Under good management conditions, Leghorns may lay up to 18 months at an economical level, some heavier breeds up to 15 months.

The time to replace a flock is determined by many factors and it is wise to consult with local poultry authorities before making decisions.

Checking feed and market price history, seasonal considerations, and historical data on breed sources used, if available, will help in decision-making. This, of course, must be done in sufficient time to allow preparations for the 5- to 6-month rearing period.

## Lighting

Light is a stimulus which has a direct impact on egg production. Increasing day length has a positive influence on egg laying. Decreasing day length has a negative influence. Thus, under natural lighting, a country hen not near the equator begins laying eggs as the days grow longer in spring. She tapers off as

the days become shorter in the fall. The new breeds respond the same way when kept in natural light.

This means that all hens in an area on a natural schedule will hit peak production at the same time of the year, thus causing overproduction and low prices in some seasons, and scarcity and high prices in others.

If you want your hens to produce best during periods of high prices, pay attention to the length of their day. Layers need 14 to 16 hours of light during a day for optimum production. If they receive less, or if the length of the day is decreasing, egg production will suffer. But, if pullets under 21 weeks old are exposed to lengthening days, they may start before they are physically ready to maintain production. This can harm them. If egg prices are even throughout the year, you can take advantage of natural lighting and hatch or buy chicks 21 or 22 weeks before the shortest day of the year (December 21 in the northern hemisphere, June 21 in the southern). That means starting the flock about July 18-25

in the north, January 19-26 in the south.

If this timing does not match local market conditions or chick availabilities, or if local weather conditions are prohibitive (monsoon rains accompanied by heavy winds), you can consider manipulating the length of the day. Chicks and pullets should have a decreasing length of day until they are 21 weeks old. When the brooder is turned off, use kerosene lanterns or electric light bulbs before sunrise or after sunset to artificially lengthen the natural day so that peak production will result at the desired time. The correct intensity or amount of light is necessary for proper lighting. You will need the equivalent of one bulb watt for each four square feet. Thus, a 40-watt bulb is sufficient for 160 square feet. For large areas, use more bulbs to ensure even distribution of light, especially onto feeders and waterers. Lamps and light bulbs get very dirty in a chicken house -- clean them once a week.

If you know how long the natural day will be when the pullets are 21

weeks old and you decide use of artificial lights will be necessary, determine your artificial light needs. The following example will help you in this decision:

Assumptions:

1. Egg prices are projected to be highest during the months of October, November and December.
2. You are in the southern hemisphere.
3. The longest day is December 21. The shortest day is June 21.

4. Your breed of chickens will begin laying during the 22nd week of age and will be producing at peak levels for about three months. Their peak three months will be from the 27th through the 40th weeks. This will occur during the months desired using the following lighting program:

First, you need to count back to the time you need day old chicks. Assume your chick supplier can provide them on March 20. Working back from the day length at 21 weeks:

<u>Weeks of Age</u>	<u>Dates</u>	<u>Day Length (hours)</u>
1 - 5	Mar. 20 - Apr. 30	Brooder Lights
6	May 1 - May 7	16
7	May 8 - May 14	15-3/4
8	May 15 - May 21	15-1/2
9	May 22 - May 28	15-1/4
10	May 29 - June 4	15
11	June 5 - June 11	14-3/4
12	June 12 - June 18	14-1/2
13	June 19 - June 25	14-1/4
14	June 26 - July 2	14
15	July 3 - July 9	13-3/4
16	July 10 - July 16	13-1/2
17	July 17 - July 23	13-1/4
18	July 24 - July 30	13
19	July 31 - Aug. 6	12-3/4
20	Aug. 7 - Aug. 13	12-1/2
21	Aug. 14 - Aug. 20	12-1/4

Now, you want to bring them into production. The natural day length on August 21 is 12-1/4 hours and you know the natural day length is increasing until December 21. After December 21, the longest day of the year in the southern hemisphere (south of the equator), the natural daylight will begin decreasing. Since you don't want the chickens to slow down in egg production due to the decreasing day length, we must begin to use artificial lighting. Thus:

-- August 21 - December 21, the natural day length increases and no artificial lighting is needed.

-- Beginning December 21, assume the natural day length on December 21 is 14 hours:

	<u>Day Length (hours)</u>
Dec. 21	Natural - 14
Dec. 22 - 28	14-1/4
Dec. 29 - Jan. 4	14-1/2
Jan. 5 - Jan. 11	14-3/4
Jan. 12 - Jan. 18	15
Jan. 19 - Jan. 25	15-1/4
Jan. 26 - Feb. 1	15-1/2
Feb. 2 - Feb. 8	15-3/4
Feb. 9 - Feb. 15	16

-- From February 15 on, keep a

steady 16 hours through the end of the 12-month laying cycle, sometime after August 21.

This schedule has accomplished the following objectives:

- The day length was artificially decreased up to the 21st week. This part is often called a "step-down" lighting program. The step-down program prevented the chickens from starting to lay eggs too early.
- The day length was increasing after the 21st week, the time when we wanted to stimulate egg production. If this had come at another time of year, we might have had to use artificial lights beginning at the 21st week.
- The day length was artificially increased beginning on December 22. If this were not done, egg production would have slowed down substantially. This series of light increases is called a "step-up" program.

For a step-up program it is important that day length increases not be made too rapidly because this can result in damage to the reproductive system. An increase in increments of 15 to 20 minutes per week is the maximum recommended.

## Forced Molting

After a year's egg production, a hen normally stops laying. She then molts, shedding and replacing her feathers. About seven weeks later, she resumes laying, but at a lower rate than the year before. The eggs will be larger than with new pullets, but will have thinner shells, resulting in more breakage. Although you feed new chickens for 22 weeks before they begin to lay and molted birds only seven weeks, the molted birds eat more per day. Most farmers sell the old flock at 18 months of age and have a new one ready to start laying.

There are times when it could pay to keep the old flock, such as if replacement birds aren't available, or if egg prices will be very high in the period two to ten months in the future. In such cases, a forced molt reduces the time needed and puts all birds on the same schedule. It usually is uneconomical to force brown-egg breeds to molt, due to their higher feed requirements.

Generally, forced molting is not a procedure used for the most genetically advanced egg layers. However, it is a procedure used in some situations. A typical case for forced molting is one in which there has been a severe nutritional or environmental stress which has resulted in a drop in egg production between the 6th and 8th month of production. The situation by that time is a flock laying perhaps at a 50 percent level, one not likely to recover to full production unless forced to molt. Forced molting is like rebuilding a car engine to make it more efficient.

To force a molt, begin when the hens are producing at a rate of less than 45 or 50 eggs per 100 birds per day. If you are using artificial lights, stop. Do not feed the flock the first two days, then for the next two days give them just enough feed so they finish it two hours before sunset. Do not provide water the first day, provide half the normal amount on the second day, and give them a continuous supply thereafter. On the 5th day, resume the lighting

program, if you use one. It will take about six to eight weeks to bring them back to full production. The flock should produce well for another six to eight months.

## Culling

Removing sick or poorly producing chickens from a flock is called culling. When you cull birds, you lessen the chance of spreading disease, and you reduce the waste of feeding non-layers.

During a flock's first five months, watch for sick birds. In village flocks of less than 50 chickens, you can put sick birds in a special pen. If they recover, they can rejoin the flock, but be careful -- an apparently recovered chicken may carry the disease back to the flock. In larger flocks, it often is better to destroy obviously sick chickens. Examine them closely, or take them to a veterinarian.

Culling may increase the profits from a laying flock by up to ten percent. This takes experience, for some layers go through pauses

in production -- culling them loses future eggs.

As you gather eggs, gently examine hens who have **just** laid. Their combs will be large, bright red and waxy, their ear lobes and wattles will be smooth and soft. The area between their pubic bones and breastbones will be large, soft and pliable, and their vents will be large, oval and moist. If they have been laying for several weeks, they will look bleached, for the yellow pigment in their bodies is going into their eggs. You can place three fingers between a good layer's pubic bones, and four fingers between her breastbone and pubic bones. Her feathers may be a bit worn and dirty from visiting the nest often.

About four weeks after laying begins, you can cull the obvious non-layers. A hen that isn't laying will have a shriveled, pale and scaly comb, her wattles and ear lobes will be rough and dry, her vent small, puckered, yellow and dry and her abdomen hard and fatty.



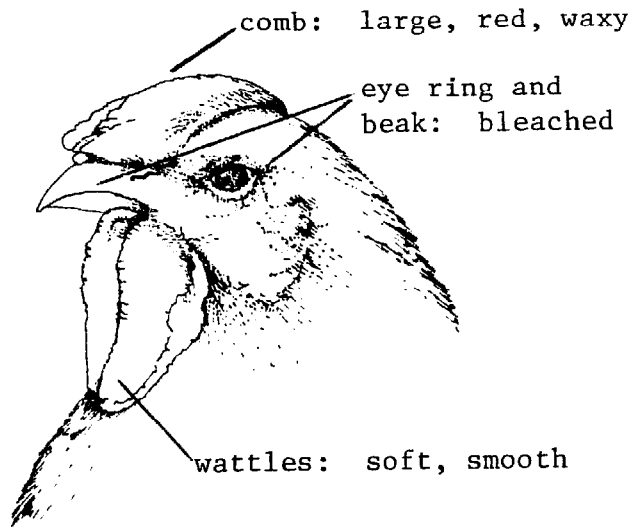

Good layer

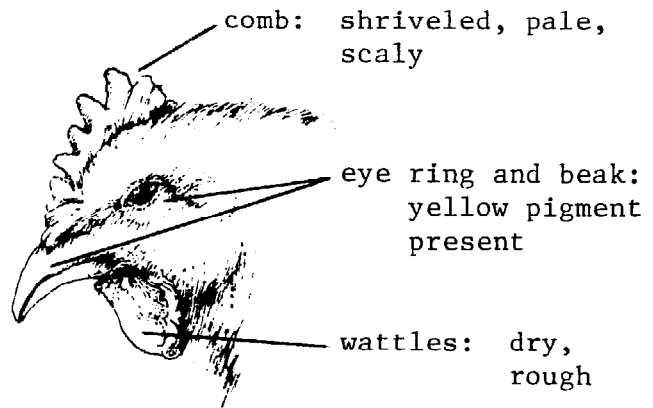

Non-layer

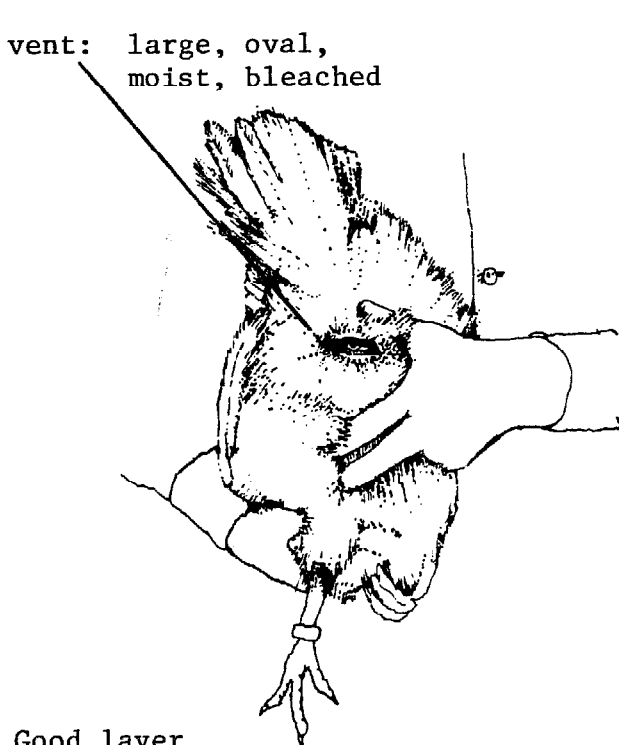

Good layer

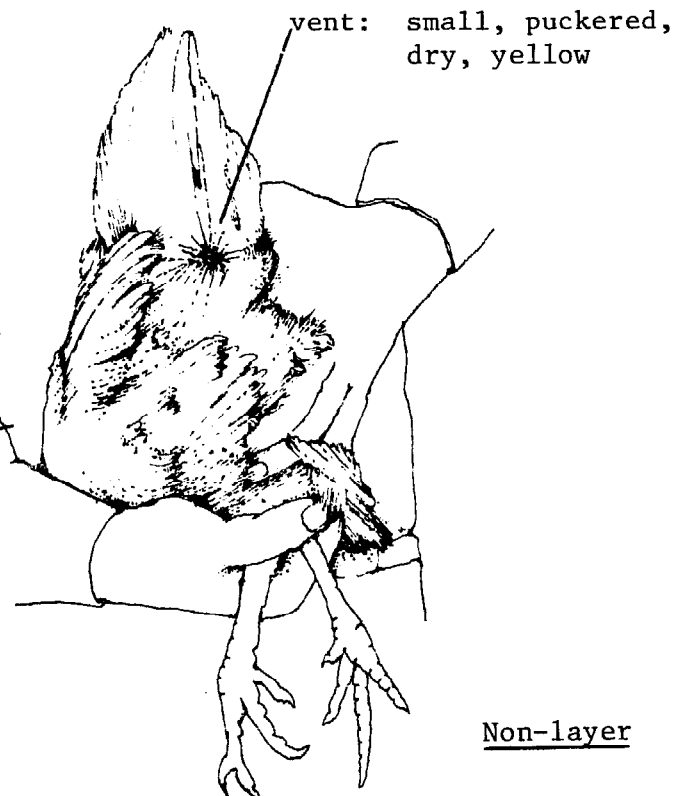

Non-layer

How to Tell a Good Layer from a Non-layer

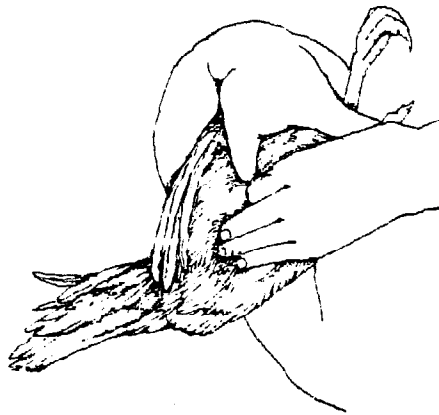

3 fingers

Good layer

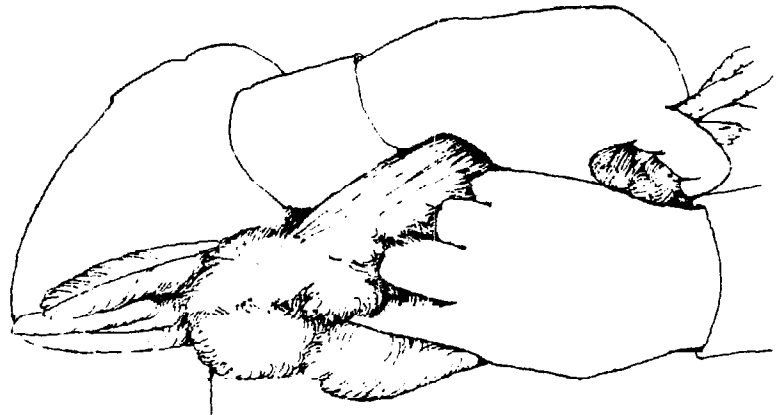

1 finger

Poor layer

Examining Distance Between Pubic Bones

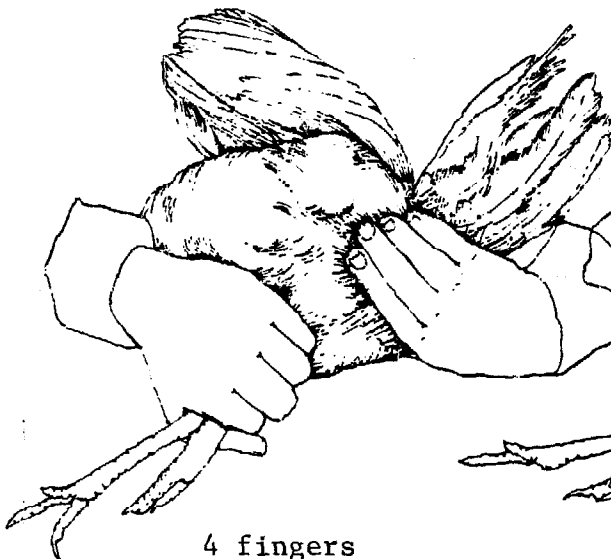

4 fingers

Good layer

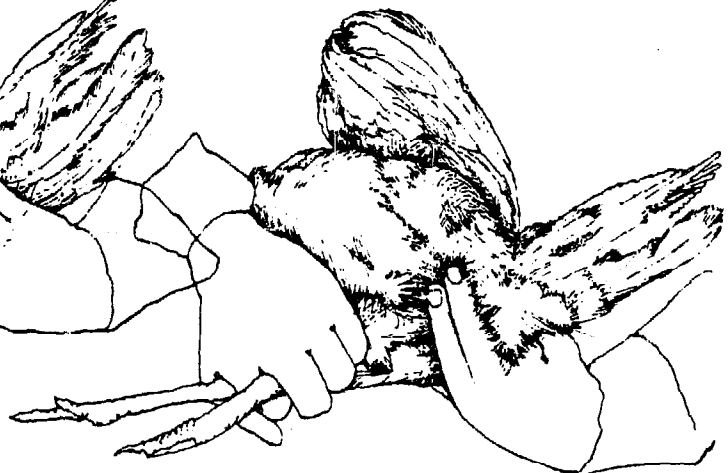

2 fingers

Poor layer

Examining Distance Between Pubic Bones and Breast Bone (Keel Bone)

# Other General Management Principles

## Stress Factors

Chickens subjected to stress will not produce at maximum potential. Examples of stress are:

- Noises -- Barking dogs and nearby automobiles frighten chickens.
- Rats and predators -- These disturb the flock as well as eat chickens and feed.
- Strange people in the house -- If possible, the same person should attend the flock every day throughout the chickens' lives. Other than a veterinarian or an extension agent, no visitors should enter the poultry house. They can view the flock through the windows. This practice not only reduces stress, it reduces the chance of introducing disease. However, many farmers will have children assist in tending the flock. This is acceptable as long as it is also done on a regular basis.
- Changes in routine -- The farmer should visit the flock at the same time each day.
- Vaccinations -- The stress of vaccinations cannot be avoided, but it can be reduced by following the right schedule and handling the birds gently.
- Moving the flock -- If possible, keep the birds in the same house all of their lives.
- Damp litter -- The smell of ammonia given off by damp litter is a stress. Also, damp litter is an ideal medium for the growth of disease-causing organisms.
- New chickens in the flock -- During the early weeks of their lives, chickens in a flock establish a hierarchy of dominance, or pecking order. When new chickens are introduced to the flock, the order has to be re-established over several weeks while growth and production suffer. New birds in the flock also can cause disease problems.
- Violent weather -- Reduce the effects of storms by partly covering windows with shutters, burlap or mats. Allow some air circulation for ventilation and remove the window covers as soon as the weather clears.
- Very hot weather -- When the temperature in the chicken house exceeds  $32.2^{\circ}\text{C}$  ( $90^{\circ}\text{F}$ ), it is an extreme stress. Above  $37.8^{\circ}\text{C}$  ( $100^{\circ}\text{F}$ ), some chickens may die.
- Cannibalism -- Chickens may attack and even kill other chickens.

- Decreased day length -- Layers need at least 14 hours of light to produce at their maximum.

In short, a stress situation occurs with each deviation from good management practices and whenever chickens are subjected to something other than the daily routine.

### **Males and Females**

Young male and female chickens can be kept together until the cockerels become sexually mature. At maturity, cockerels should be isolated from the females because they will begin to bother the females, as well as each other, creating a stress situation. Cockerels are sexually mature when their combs and spurs show rapid development. This will occur between 12 and 18 weeks of age.

### **Mortality**

Expect to lose about one percent of the flock per month. Some will die suddenly; others will show obvious signs of disease. Remove

them and perform a post mortem examination. If the mortality exceeds one percent per month seek veterinary advice immediately. This may be an early warning of a severe outbreak.

It is best not to eat obviously diseased birds or those who die of unknown causes. Bury the bodies in the ground. If wild animals or dogs dig up buried chickens, you will have to either burn the bodies or construct a deep pit in the ground with a solid cover.

For small flocks of 50 to 100 chickens or less, you may want to use an isolation pen for the period of sickness. In larger operations, this is not a good practice.

### **Hot Weather**

Chickens do not perspire for relief from heat -- instead, they pant and hold their wings out from their bodies. When the temperature exceeds 37.8° C (100° F), chickens may die from heat stroke. Make sure the chickens have plenty of shade and cool drinking water. Completely open all ventilation areas. Add

extra waterers or buckets of water to reduce crowding. Chickens in cages should be sprinkled with water, especially if any deaths occur. Chickens on deep litter and the deep litter itself can be sprinkled at mid-afternoon to increase evaporation.

## Cannibalism

An accidentally injured bird with blood on it will be pecked, sometimes to death, by other birds.

Pecking also may start when the chickens are overcrowded, fed an inadequate diet (especially a salt and/or protein deficient diet), are growing permanent feathers or when there is a lice or mite infestation. Thus, to prevent cannibalism, good management is of prime importance.

Once a pecking problem occurs, the best action to take is to debeak the chickens. But other measures may help. These include:

- Reduction of flock density by expanding space available or removal of some birds.

- Placing evergreen boughs (such as pine) with needles, leaves, fresh-cut green grass, torn up newspapers, etc., in the pen when pecking begins to be a problem. The chickens will be diverted to pecking at these, rather than each other.
- Improving the diet.
- Treating for lice or mites.
- Spreading pine tar or other non-toxic, bad tasting substances or commercial preparations over the wounds of pecked birds.
- Always removing pecked birds from the flock.
- Removing the most aggressive birds from the flock temporarily.

Debeaking -- To prevent chickens from pecking each other and reduce feed wastage, many farmers make it a standard practice to cut a portion of the upper beak and the tip of the lower beak off. Other farmers debeak only if the flock starts pecking.

Do not debeak if they are allowed to range for food. Debeaked chickens cannot pick up food from the ground. If a cannibalism problem develops in range chickens, cutting the tips of both top and bottom beaks

equally, or just burning back of the beak with a red-hot iron, will usually solve the problem.

Layers put in colony cages should be severely debeaked. Layer type chickens should be debeaked before they start producing eggs. For meat birds being fed growing mash, just cut 1/3 of the top beak so they can scoop up the feed and eat more easily.

Equipment specifically designed for debeaking is now available in most countries. Debeakers may be found at poultry extension offices, larger poultry farms, cooperatives or equipment dealers. These electrical devices are designed to cut and cauterize with a hot blade and are quite efficient for debeaking large numbers of chickens at any age.

To debeak baby chicks, just

burn back the top beak quickly. For older birds, hold the tongue back with the tip of your index finger, cut and cauterize the beak as shown in the illustration below. Where this equipment is too expensive or not available, chicks also can be debeaked with nail clippers, a sharp knife or another similar sharp device. Cut off 1/3 to 1/2 of the upper beak and the tip of the lower. Press a red hot iron to the beak to cauterize it and stop the bleeding.

Older birds can be debeaked using a sharp knife or similar object. It will take two people, one to cut and the other to cauterize it.

After debeaking, feed should be kept at least 2.5 cm (1 in.) deep for the next two days to prevent the tender beaks from banging against the feeder bottom.

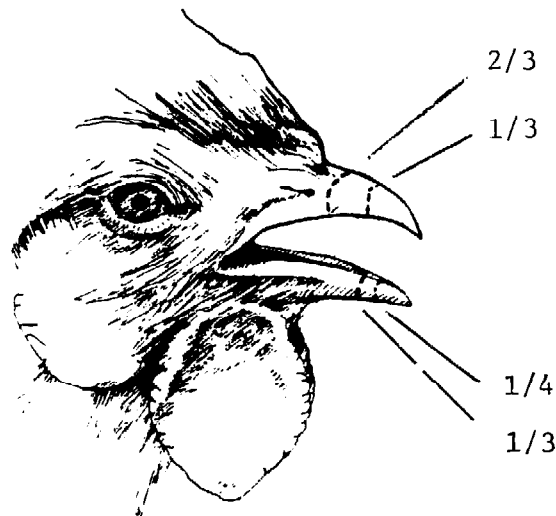

Debeaking -- The top beak should be cut back  $1/2$  to  $2/3$  for layers and  $1/3$  for meat chickens while the bottom beak should be cut  $1/4$  to  $1/3$  for layers and not at all for meat birds. Birds on an open range should be debeaked only if a problem with cannibalism occurs. In this case, it is very important to debeak both top and bottom beaks equally.

## Rat Control

Rats and mice are the financial enemies of people raising poultry. One rat eats as much feed as an adult chicken every day. They also spread disease, eat young chicks and disturb the flock. Snap traps and locally recommended poisons can be quite effective, but take care that chickens, other animals and children cannot get at them.

Poison bait should be placed

in a small tunnel or box with an entrance at one end and an exit at the other and located inside poultry house corners or near entrances to rat tunnel holes found around the perimeter of the chicken house or feed storage areas.

## 6. Housing and Equipment

Local climate, building methods, management systems, space available and size of flock all will influence the construction of a chicken house and other equipment. Of these considerations, the management system selected probably is the most basic.

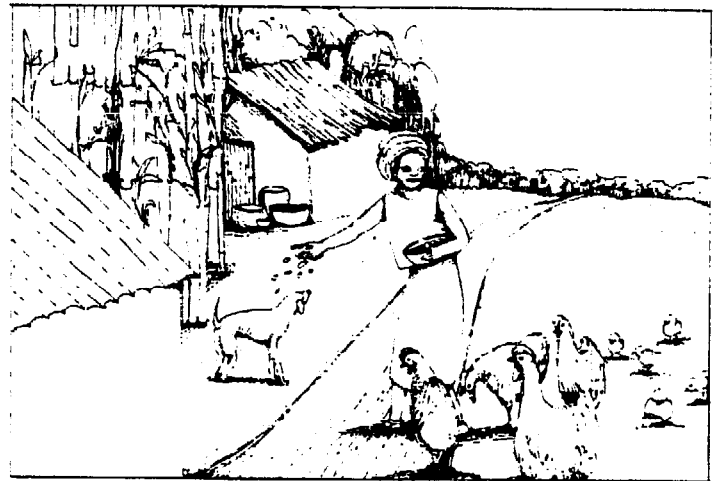

### Free-Range

Whether or not overnight shelter is provided, any kind of free-range system usually is unacceptable for the new breeds. Losses to disease and predators will be much too high to justify costs.

### Contained, With Limited Range

The many variations of this system all seek to protect the chickens from disease and predators while allowing them to find some food for themselves in a fenced-in area or range.



Advantages:

- The cost of feeding the chickens can be reduced by as much as 20 percent if the range is well managed with a good growth of grass.
- Using grassy areas under fruit or other crop trees as range can mean more efficient use of that land.
- Sunshine provides vitamin D; chickens kept out of the sun need supplemental vitamin D in their feed. (Note: depending on their diets, chickens will need other vitamin supplements as well.)
- Exercise and outdoor life produce tougher, but tastier chickens that some people prefer.
- Inside a fence, the chickens receive some protection from predators.
- Isolating the flock from other chickens provides some degree of disease protection.

- What the chickens eat outside the house can be estimated and allowed for when mixing feeds.
- When the range is large, stress due to crowding is reduced.

Disadvantages:

- In areas with prolonged rains, the chickens stay inside the house both night and day. Therefore, houses have to be as large and well equipped as those without ranges. Thus, in addition to equal housing costs, farmers must pay for fencing.
- If grass on the range is sparse, savings on feed costs will be slight. Land that grows lush grass often is more profitably used for cereal grains or other food crops.
- Unless the fence is at least 2 m (6 ft.) tall, the farmer will have to clip the flight feathers on one wing of each bird. Small, light

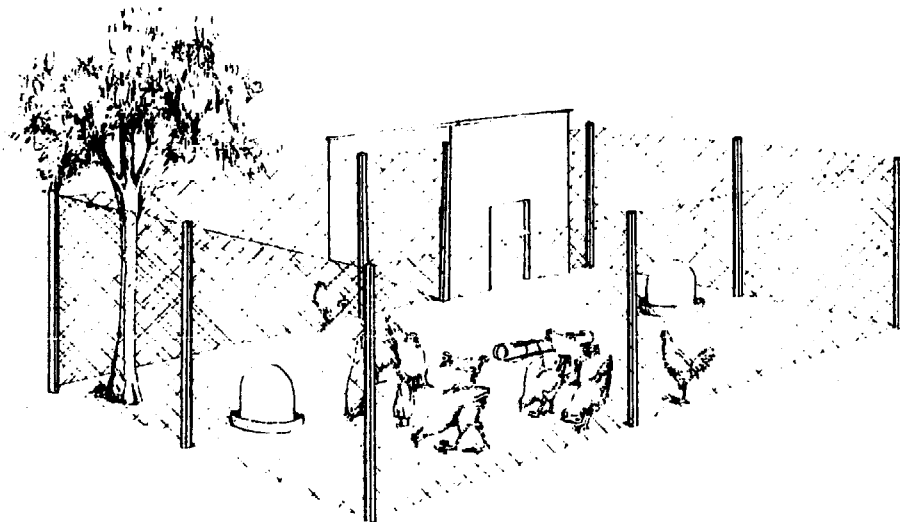

breeds can fly over even taller fences.

- Other species of birds entering the range will carry pests and diseases, especially fowl cholera.
- The chickens should be rotated to fresh range every few months to prevent the build-up of disease-causing contaminants in the soil, which requires more land.
- Maintaining a range as well as a house requires more labor than maintaining just the house.

Recommendation -- Unless unusual local circumstances favor this system, farmers will do better using a fully contained one.

## Contained Systems

Contained systems allow the farmer more control over diseases and feed, and provide protection to the birds against predators. These systems vary from makeshift cages in the corner of a veranda or porch to fully automated batteries of

thousands of birds. This manual concentrates on those of smaller scope, but the principles are the same no matter how large the project. Basically, there are three kinds of contained systems.

### Deep-litter

Properly managed deep-litter systems provide excellent environments for the improved breeds and yield valuable fertilizer as well.

#### Advantages:

- Deep litter is a good insulation. It protects chickens from cold weather, and during hot seasons they can nestle into it and reach the cool floor below.

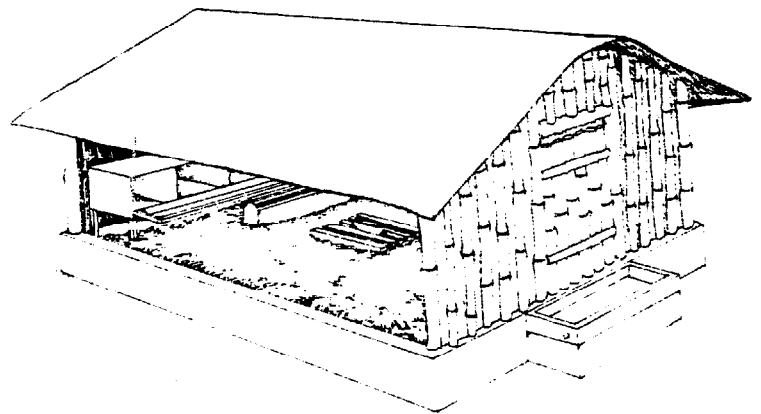

- Studies show that when all other factors are equal, layers produce more eggs on deep litter than in cage systems.
- Chickens can be brooded and kept through their productive lives in the same house.
- Deep litter allows the bird to dust itself against lice and other parasites.
- When a production cycle of 100 layers is finished, the litter and manure combination will be enough to fertilize a 0.4 hectare (ha) (1 acre) area of rice, wheat or other cereal grain, or 0.2 ha (1/2 acre) of intensively cultivated vegetables. (Note: Do not apply manure directly to growing crops -- its high nitrogen content will harm them.)
- Deep litter is an improved system which is readily adaptable to traditional night shelters used in many village situations.
- The chicken, by nature, scratches and pecks in the litter, reingesting wasted and undigested food. In this process, some of the feed is recovered. At the time, the chicken picks up enzymes which are believed to reduce the chance of "gizzard erosion", a problem which rarely occurs when

chickens are kept using the deep-litter system. Also, fatty liver syndrome is less likely in floor birds.

#### Disadvantages:

- There is a greater chance of worm and tick infestation and coccidiosis (internal protozoan parasites) than with cages or raised floor systems.
- The deep-litter system is inappropriate for very humid areas (80 - 90% humidity) -- damp litter spreads diseases.
- The litter must be turned often, particularly in damp weather, and this requires more labor than other contained systems.
- Sometimes adequate litter is difficult to obtain.

Recommendation -- Deep litter is recommended for both meat birds and layers.

#### **Raised Floor**

Floors, raised to about 1 m (3 ft.) above the ground, are made of wooden slats, wire mesh or expanded metal. The chicken droppings should be collected frequently from under the house and composted.

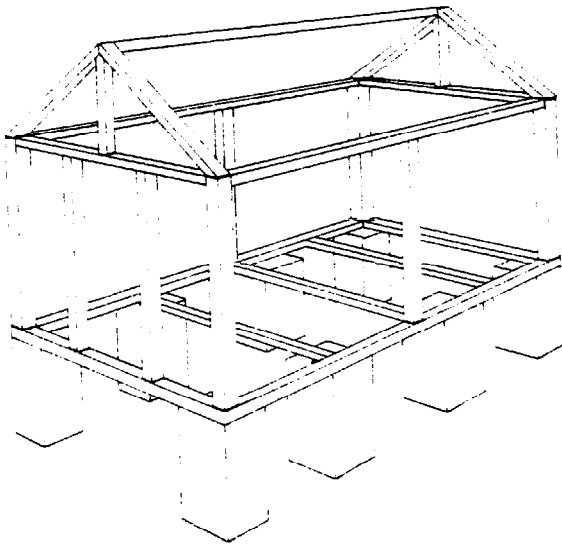

#### Advantages:

- In very humid climates, this is a healthier system for chickens than is deep litter, because disease transmission through fecal matter is minimal.
- This system often is better suited for a few birds than is deep litter.
- In some areas, it costs less to build a raised-floor house than a deep-litter house.

#### Disadvantages:

- Young chicks cannot be brooded well in these houses. Since the floor is not insulated, it is difficult to maintain the high temperatures the chicks need, and walking on such floors is

very difficult for chicks. Thus, a separate brooder house is needed.

- These systems are unsuitable for hot, dry climates because the floors heat up, unless they are built near shade trees. They also are unsuitable for use in cold seasons due to their lack of insulation.
- Unless the droppings are well managed, they can attract flies and cause objectionable smells. Their value as fertilizer also is reduced.
- Egg production probably will be lower than with deep-litter.

Recommendation -- Use in humid areas, where litter material is not available and where construction costs are lower than for deep litter. Also recommended for both meat breeds and layers.

### Cages

Cages allow the maximum in control. They can be used for any number of birds, and construction costs can be geared to the desired size of the flock.

#### Advantages:

- Cages can be placed under existing roofs; thus, a spe-

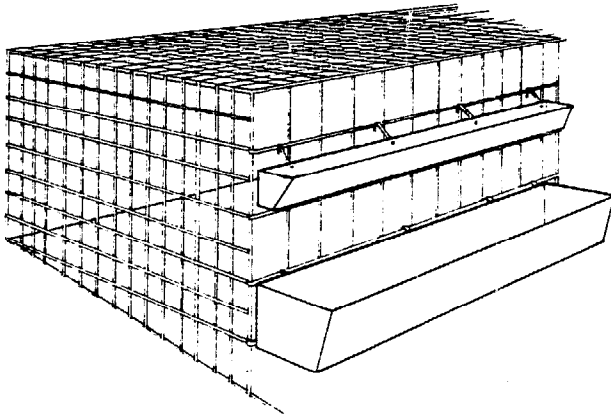

cial building may not be required.

- With cages more birds can be kept in a building than on deep litter.
- Less labor per bird is needed than with other systems.
- Poor layers can be identified immediately and culled, thus saving feed.
- Problems with parasites, particularly ticks, are reduced, but nutrition may be a problem.
- When properly constructed, cages can last many years.
- Fewer disease problems are caused by transmission through fecal matter.
- Cages are a cheaper investment in the long run due to ease in care and feeding of the birds.

Disadvantages:

- Cages are hard to construct

properly.

- They involve very high initial investment per bird.
- There must be constant and excellent ventilation.
- There are more broken eggs than with deep litter.
- The feed must contain all necessary vitamins and minerals needed by birds.

Recommendation -- Cages are good for climates with high humidity, where labor costs are high, and when a farmer wants to keep a large flock of layers. Where ticks are a problem, cages are especially advantageous. Cages are recommended for layers, but not generally used for meat birds.

## Building a Chicken House

A good chicken house, no matter what its size or which materials are used for it, has certain essential features. These essentials, dis-

cussed further below, include a water-tight roof, good ventilation with no cold drafts, internal surfaces that are easy to clean, adequate floor space for the number of birds contained, rat-proof floors and walls and a well-chosen location.

Some sample chicken house designs are given in Appendix A (p. 175). The Peace Corps' Manual Number 6, Self-Help Construction of One-Story Buildings, (available through ICE - see inside front cover), offers information on general construction principles. If you will be building a chicken house, try first to build a model out of paper or cardboard. General considerations in building a chicken house are given below.

### Sites

Sometimes there is no choice of where to put a chicken house. If there is a choice, features of a good site are:

- Well-drained land not subject to flooding. This is espe-

cially important for deep-litter systems.

- Within sight of the farmer's home, but far enough away from other buildings to allow for good ventilation.
- Near a source of clean water.
- In areas of high winds, the site should be protected by a hill, stand of trees or other windbreak. Otherwise, a solid wall facing the prevailing monsoon or rain direction may be better.
- Well away from other chicken houses to reduce the spread of disease. An absolute minimum of space between houses is 10 m (32 ft.), but the more, the better.
- In hot climates, placing the house under tall shade or crop trees, such as coconuts, will protect it from the sun. Bushy trees that block ventilation won't do.
- Away from roads, work areas, and other noisy places to reduce stress caused by disturbances.

### Floor Space Requirements

A crowded chicken is an unhappy, unproductive chicken prone to peck other chickens, sometimes so severely that they die. Putting too many birds

in a confined space is a false economy.

Below are recommendations on space requirements. Large layer breeds will need somewhat more space than small ones. More space will be needed in very hot and/or humid climates. Some farmers have experimented with crowding chickens purposely to reduce their per-bird investment in housing and equipment. They have reduced the space per bird to as little as 930 sq. centimeters (1 sq. ft.), but usually have found that providing less than 2,250 sq. cm (2-1/2 sq. ft.) per bird, even with sophisticated ventilating equipment, is unprofitable.

A common sign of overcrowding is when the birds begin pecking each other. The only practical remedies available to small farmers are to provide more space, which may be difficult, reduce the size of the flock or debeak the chickens (see page 77).

Meat breeds -- Space requirements should be based on the maximum size the flock may attain with good care and good luck. If

110 chicks are purchased, ten probably will die during the 8- to 12-week growing period. One hundred ready-for-market birds need 14 sq. m (150 sq. ft.). If they are kept beyond 12 weeks, they will need more space -- at least 28 sq.m (300 sq. ft.) by 14 weeks, but they should be sold before this age.

Layers -- Because they will be kept longer than meat birds, start with 115 sexed chicks for every 100 layers desired. Average space requirements for small breeds of layers (White Leghorns, for example) are given in the table on the following page. Under good management, 0.225 sq. m (2.5 sq. ft.) per lighter breed layer is sufficient, and this is recommended for more experienced farmers using a deep-litter system. On slatted floor systems, 0.18 sq. m (2.0 sq. ft.) is sufficient space per adult bird. A space of 27 sq. m (300 sq. ft.) should be enough for 100 layers throughout their life, and enough for 200 broilers up to the age of

Age in weeks	Space per Bird		Space per 10 Birds	
0 - 6	650 sq. cm	100 sq. in.	6.5 sq. m	75 sq. ft.
7 - 12	930 " "	1 sq. ft.	9.3 " "	100 " "
13 - 16	1,860 " "	2 " "	18.0 " "	200 " "
17 & up	2,790 " "	3 " "	27.5 " "	300 " "

12 weeks. Note: This is living space needed. It does not include space occupied by feeders, waterers and other equipment.

### Ventilation

Chickens need more fresh air per unit of body weight than any other livestock. In addition to stale air, they exhale or excrete large amounts of moisture, up to 0.37 liter (3/4 pint) per bird each day. High humidity in a chicken house encourages the spread of disease, so good ventilation is important. Electrical fan systems are needed for wide or densely populated houses. Natural air circulation or gravity systems (natural circulation assisted by flues) should not be used for houses wider than 9 m (30 ft.). In hot, humid climates, many large windows or screened openings are needed. They should not be blocked by brush or nearby buildings.

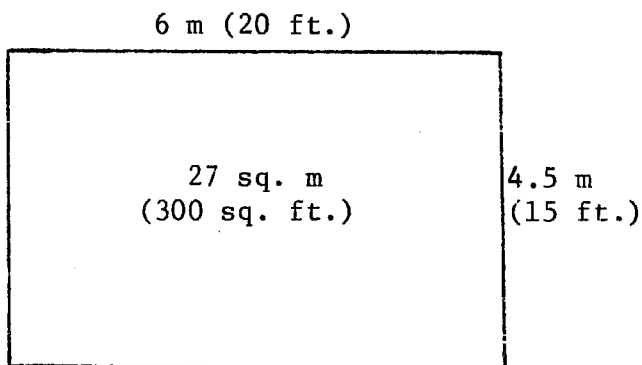

### Space Requirements for Chickens on Deep Litter

Dual-purpose breeds -- Space requirements for dual-purpose breeds are the same as for meat birds until the males are sold. After that, use the recommendations for layers.



## Framing

Local construction methods and materials, the weight of the roof and placement of doors and windows (if used) will determine the design of the frame. Internal pillars may be needed to support the roof, usually an 8 cm (3 in.) or thicker support for every 9 sq. m (100 sq. ft.) of floor space.

Chickens need overhead space, especially in hot climates. The roof should be six to ten feet above the birds to allow hot air and ammonia to rise away from the chickens. The height of the building also is determined by the people who will use it. They should be able to work within at such tasks as cleaning equipment and turning litter without excessive bending.

## Walls

The walls can be made of any local inexpensive material such as wattle and daub, bamboo slats, adobe, low-grade or used lumber and so on, as long as it is relatively rat-proof. In areas with cold seasons, walls

should be thick or insulated. In places where it never gets very cold, thatch can be used, but it should be backed by rodent-proof wire mesh and should be changed between flocks to reduce parasite and disease problems. The insides of the walls, if possible, should be smooth (plastering with cement is ideal), so they don't harbor ticks and can be cleaned easily. Interior partitions are not needed in a chicken house; they just reduce ventilation.

## Roof

The roof should be as rainproof as possible. If the house has no shutters or other window protection, the roof should overhang the walls by 1 m (3 ft.). It can be made of:

- Thatch -- Usually the cheapest material available and it provides good insulation. It probably will have to be replaced every three years, and if ticks get into it, it should be replaced immediately. Thatch should be interlaced with bamboo slats or similar material to keep predators out.
- Sheet metal -- This usually

is too expensive, and in hot climates it should be covered by thick thatch or other insulation. It is easily cleaned, an important advantage where ticks are a problem.

- Tile -- Although usually more expensive than thatch, sun-baked tile will last much longer. Because of its weight, the framing for a tile roof must be stronger than for other materials.

## Windows

Window design depends on local climate. Chickens need more fresh air than humans, but should be sheltered from wind, dust and rain. Prevailing strong winds should be con-

trolled. During storms, windows on the windward side of the house can be covered by hinged, permanent shutters, burlap bags, straw or bamboo mats, etc. In humid climates, window design should take as much advantage of the sun as possible to reduce the amount of moisture in the house, but the chickens should have some shade at all times.

Window areas are best covered by wire mesh or expanded metal. Bamboo or wooden slats can be used, but this will reduce ventilation. In the end walls of gable buildings, a ventilation hole should be located near the roof peak.

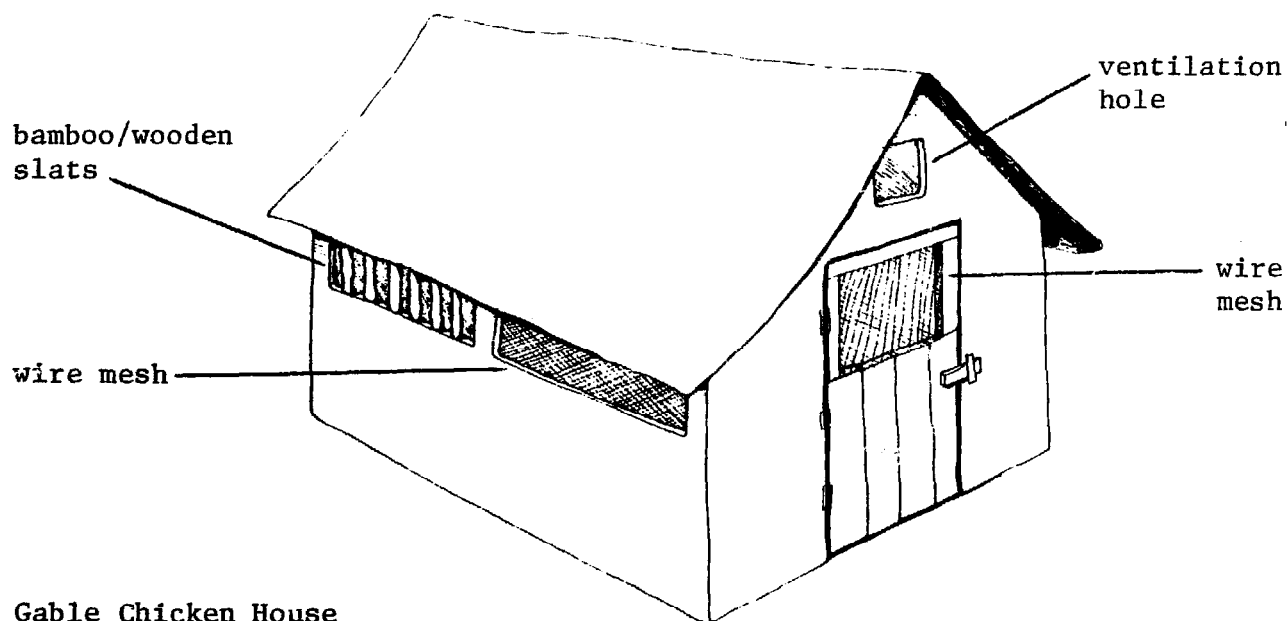

Gable Chicken House

## Door

Whether made of metal, wood or bamboo, and whether solid or of wire mesh in the top half, the door should be sturdy enough to be opened and closed more than 1,000 times a year.

## Deep-litter Floors

The ideal floor for a deep-litter house is a concrete one designed for good drainage with heavy wire mesh imbedded in it to keep rats out. This, of course, is expensive. Strong bricks or large, flat stones can be used, but are harder to clean. Many small farmers are limited to clay floors.

Deep-litter floors should be built in a well-drained area. If possible, put down a layer of heavy gravel or wire mesh first to keep rats out. Turn the edges of the mesh up about 25 cm (1 ft.) to join the walls. The floor should be about 15 cm (6 in.) higher than the surrounding ground and slope slightly from the center to the sides for

drainage. Pack it by tamping until it is firm and very smooth so that water can't collect in holes. If possible, cover it with a 5 cm (2 in.) layer of cement. Otherwise, a fresh layer of clay should be applied between flocks. In order to reduce disease problems, the floor of a poultry house must be constructed such that thorough cleaning is possible between flocks or batches of chickens.

Disinfectant Dip -- An optional but highly recommended part of a deep-litter house is a shallow, water-tight basin set flush with the door sill and filled with disinfectant. A disinfectant dip has several advantages. First, it helps reduce the transmission of disease-carrying dirt. Second, and just as important, it is a daily reminder to the farmer of the importance of sanitation. It is especially important where barefoot farmers, or those who do not have spare pairs of shoes for each chicken house, visit more than one such house each day. The dip can be formed with mud or clay

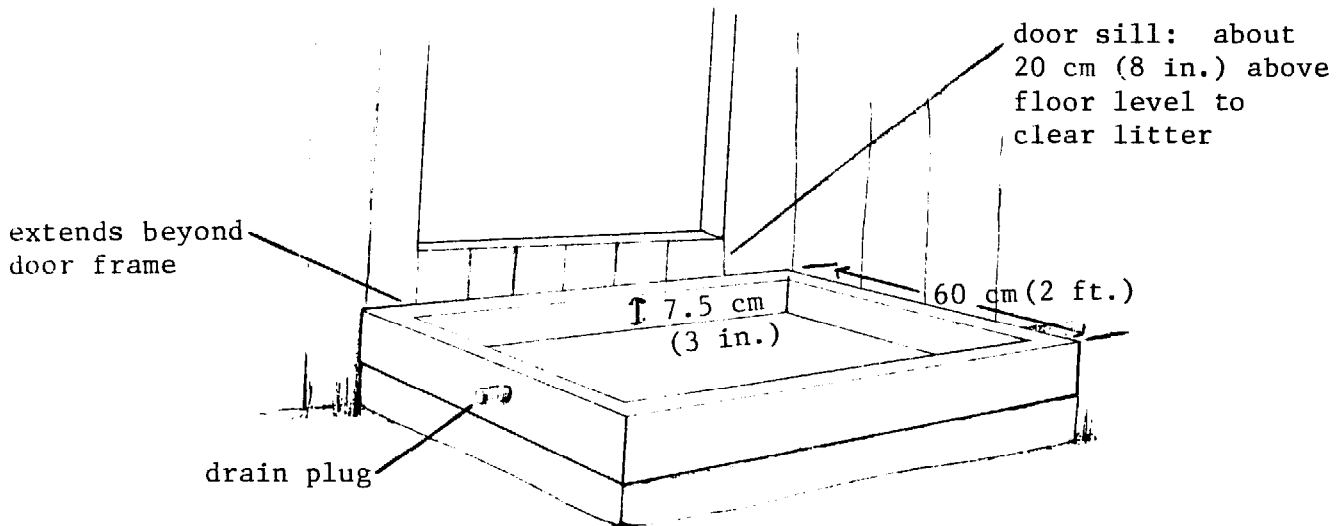

Cement-lined Disinfectant Dip -- The dip should be large enough so that it is difficult to avoid stepping into.

and lined with concrete or a sheet metal tray. In some cases it may be better to construct a shallow basin-like dip instead. A basin-like dip should be no more than 1/2 inch deep with a large center area. This has advantages over a deeper dip because the disinfectant solution and the accumulated dirt can be swept out. People also are more likely to walk through a shallow dip than a deep one.

### Raised Floors

Again, local practicalities will influence selection of materials and design. Pillars that are not rot resistant should have stone or concrete footings. Pillars may be made of wood, bamboo, oil drums, concrete blocks, etc.

Floors should be about 1 m (3 ft.) above the ground -- lower floors are difficult to clean under; higher ones result in an unsteady building. Floor joists, depending on their strength, are spaced 1 to

2 m (3 to 6 ft.) apart. The floor can be:

- Wire mesh -- The wire should be strong or "heavy gauge", as large in diameter as a standard pencil lead, if possible. The maximum space between wire in at least one direction should be 2.5 cm (1 in.).
- Slats -- Made of either wood or bamboo, slats should be 2.5 cm (1 in.) at the top and slightly tapered downward. They should be set 2.5 cm (1 in.) apart.

- Expanded metal -- Expanded metal, although expensive, is extremely durable. It should meet the same requirements as wire mesh (above).

## Making Wire Cages

In many poultry producing areas, artisans specialize in making entire cages, or they may provide just the front, the most complicated part. Colony cages (up to 20 birds per unit), which use less material, cost less than double (two-thirds) cages, but egg production may be lower. Layers placed in cages should be debeaked severely (see page 77). If you would like to make your own cages, you can use this relatively simple design. More elaborate designs use dropping boards or rolls of tarpaper to catch droppings.

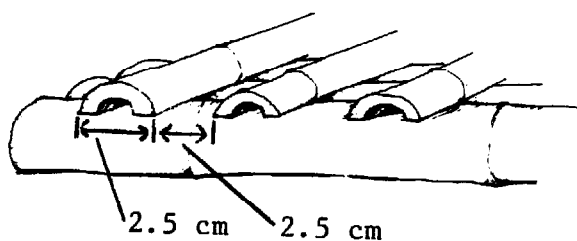
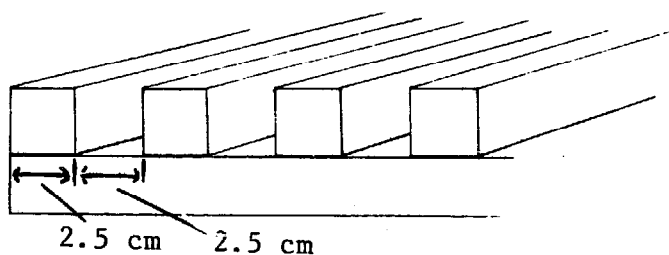

Slatted Floors

## Materials

Wire mesh A -- Wire with diameter of 2 mm (1/8 in.) welded into mesh spaced 2.5 x 5 cm (1 x 2 in.). This mesh is used for all parts of the cage except the front.

Wire mesh B -- Same diameter wire welded into mesh spaced

5 x 10 cm (2 x 4 in.). This is used for the front.

Wire -- Any heavy gauge but pliable wire, to be used to join cage parts.

## Form

Cut a piece of wire mesh A 3.66 m x 150 cm (12 x 5 ft.) and bend it as shown.

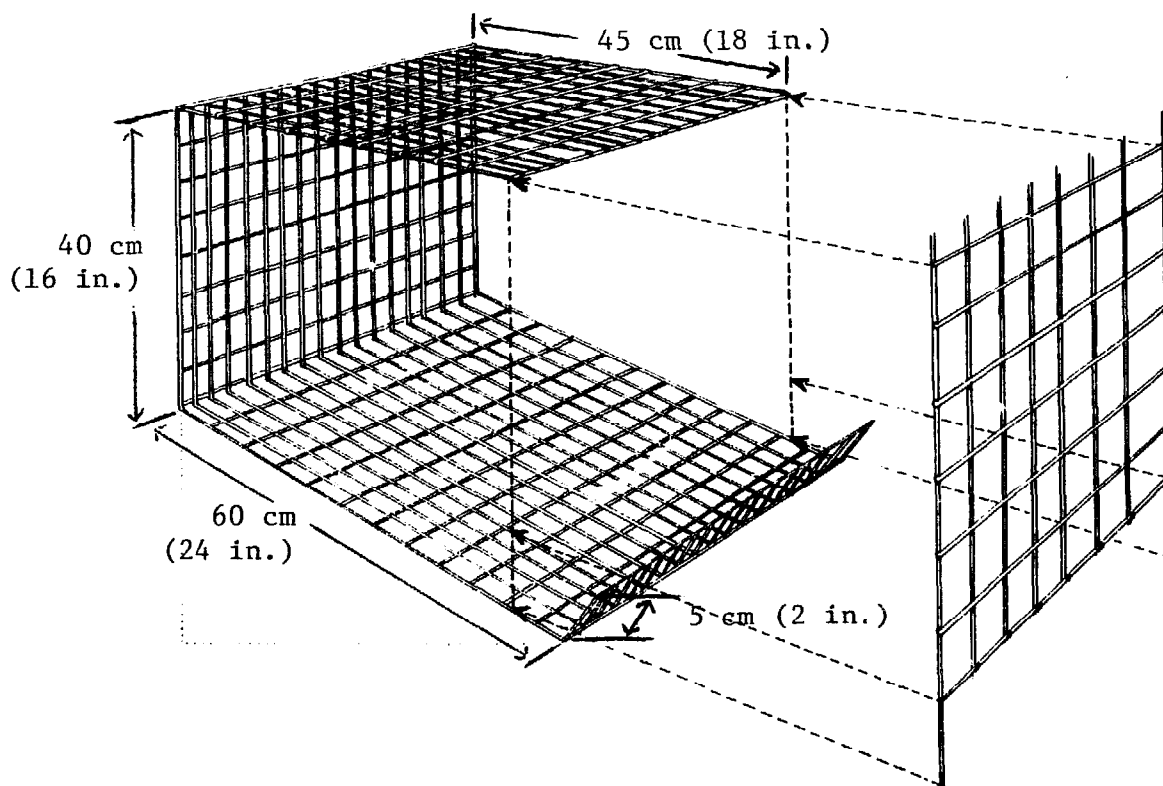

A Wire Mesh Cage Form -- The 2.5 cm (1 in.) spaced wire should be inside the cage so that the eggs will roll out.

## Sides and Dividers

Cut pieces of wire mesh A 40 x 45 cm (16 x 18 in.). Use four such pieces, spaced 122 cm (4 ft.) apart, for colony cages; use 17 spaced 22.8 cm (9 in.) apart for double cages. Secure the sides and dividers to the form with wire every 15 cm (6 in.) on the three sides that touch the form.

## Front

Cut a piece of wire mesh B

38 cm x 3.75 m (15 in. x 12-1/4 ft.). Use the protruding wires on the sides and top of the front to join it to the form. Secure the front to the cage dividers with wire.

## Door Opening

At the center of each cage, cut a door opening 15 x 30 cm (6 x 12 in.).

Sliding Door -- Using wire mesh B, cut a piece as shown by the darker lines. Bend the horizontal wires of the door opening, as shown below.

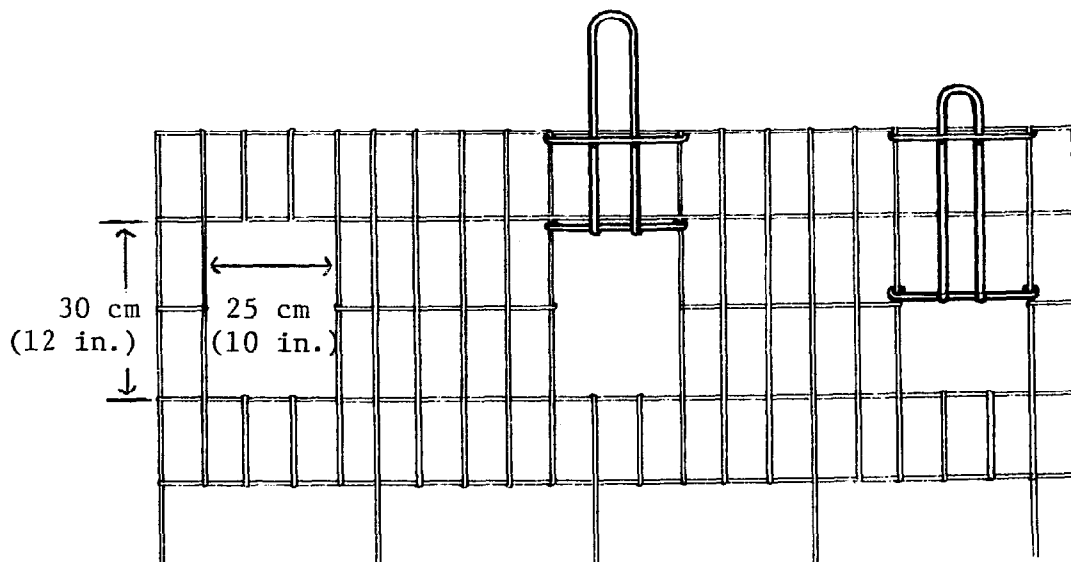

A Sliding Door

## Feeders and Waterers

Feed and water troughs made of sheet metal and mounted with wire hangers run the length of the cage. If possible, the waterer should be secured on the opposite side of the cage from the feeder. Split bamboo can be used for feeders. Both feeders and waterers should be hung

as high as possible on the cage to reduce feed wastage and splashing of water onto the feeder and poultry house floor, certainly not higher than the chicken can reach. A good rule of thumb is to place equipment no higher than the tail feathers of the chicken being put into the house or cage.

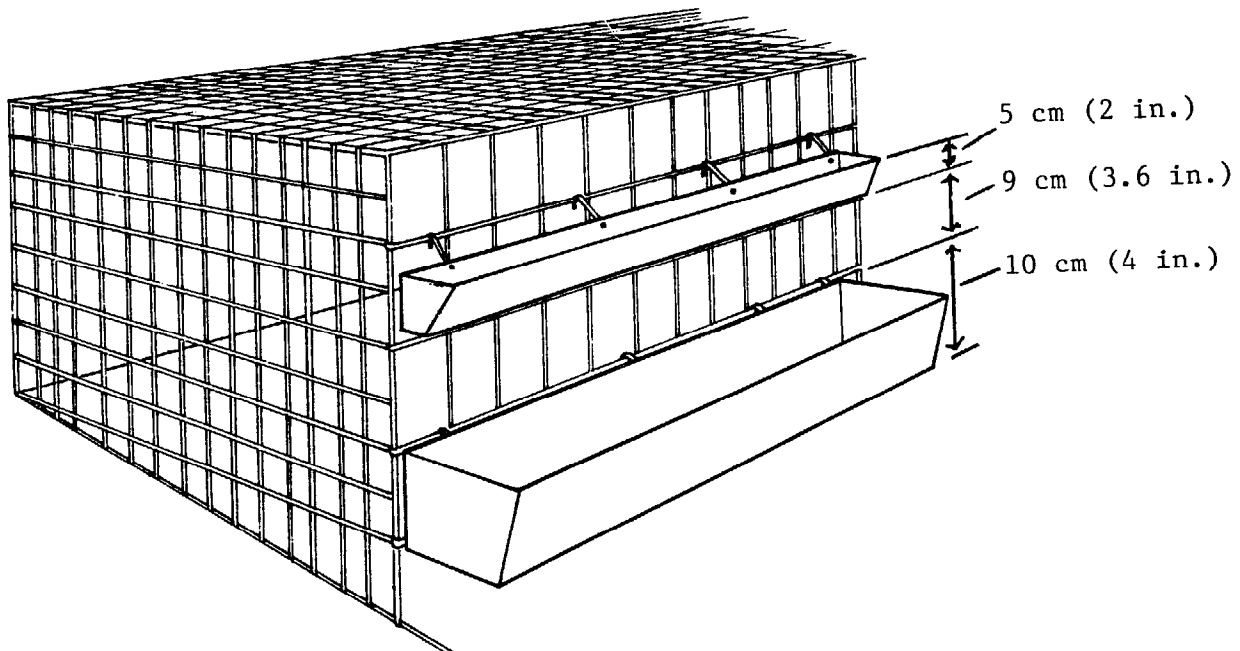

Feed and Water Troughs



# Use of Cages

This cage is suitable for 18 layers, six to each colony cage or two to each double cage. Note: The cage must be hung so that the back of the floor is 7.6 cm (3 in.) higher than the front. This allows the eggs to roll out. Excessive slope of the cage floor will cause the eggs to break as they roll.

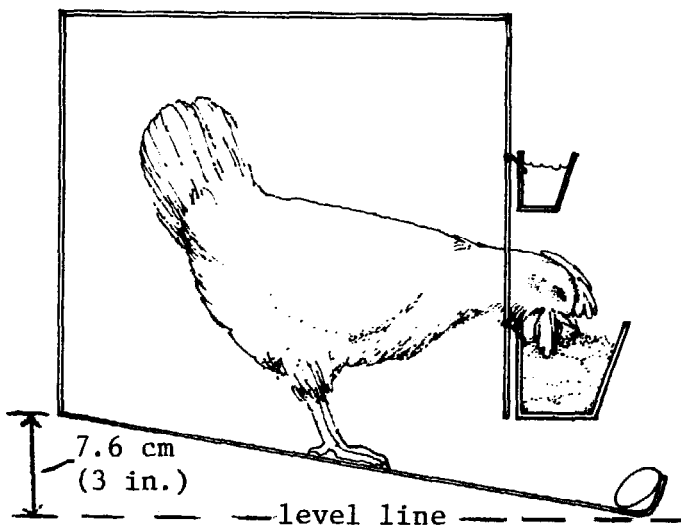

Hang cage on a slant so eggs will role out.

A single cage can be placed on a stand, or one or more cages can be hung from beams. The figure on page 99 shows a 72-bird system that occupies 8.75 sq. m (85 sq. ft.). The cages should be at least 62.5 cm (25 in.) above the ground or floor, and the area below them should be cleaned frequently.

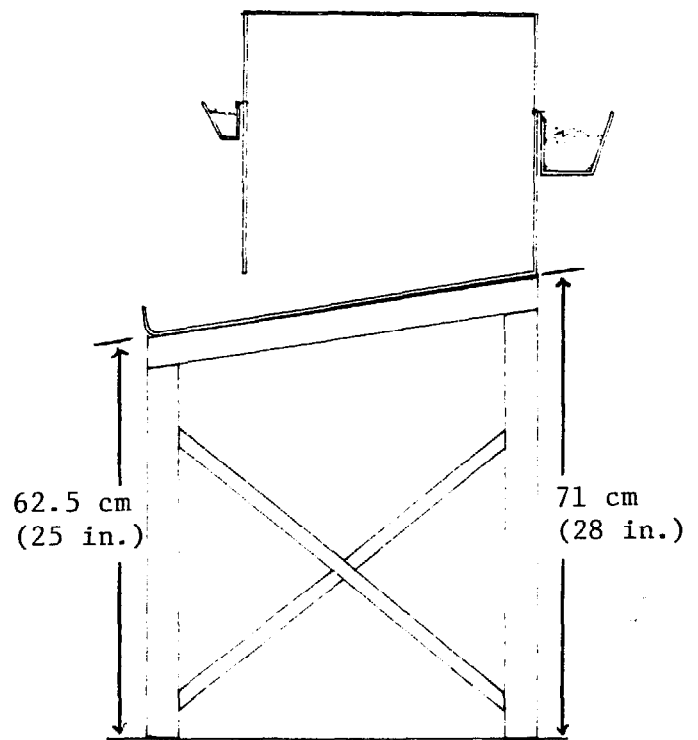

Cage on a Stand

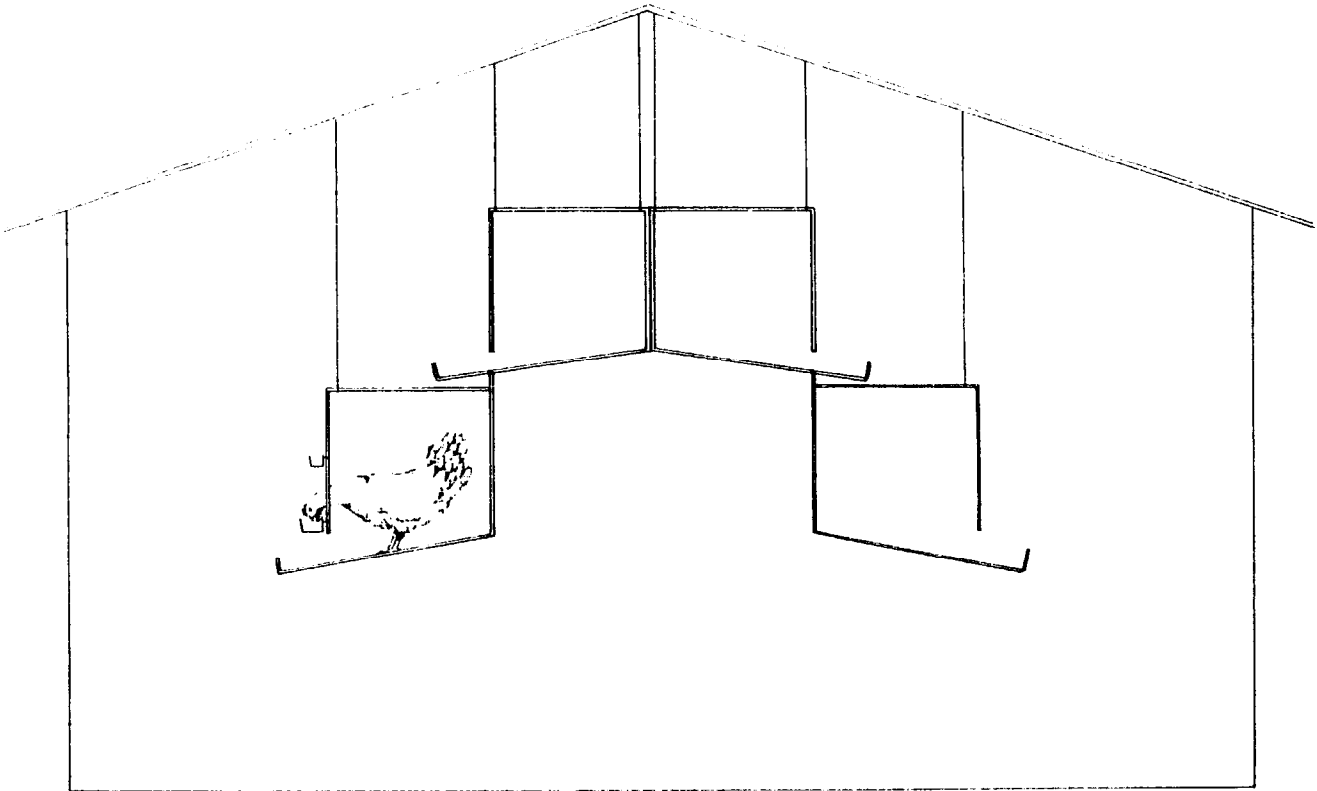

Cages Hung from Beams

The above cage designs, which slant on all sides when hung, are recommended where wire costs are high. This design has a certain

disadvantage: the feeders and waterers will have to be tightly secured to the cage to prevent them from hanging away from the cage.

An alternative design uses a little more wire for the front of the cage:

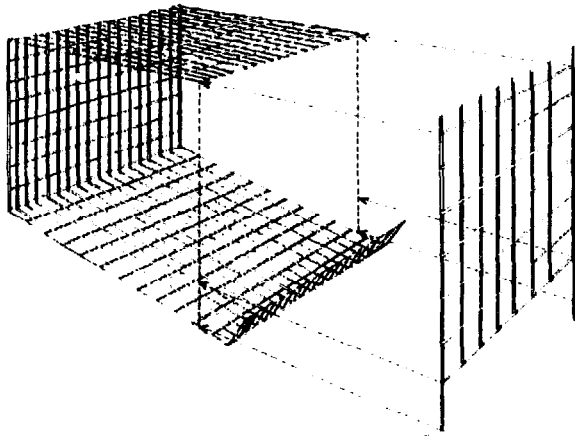

## Equipment

Equipment used in chicken houses can be made of local materials. This equipment receives heavy use and is

cleaned often so it should be sturdy. Local wood and metal workers can help with design and construction.

### Waterers

Watering space -- Whether you use a straight trough or round waterer, the length or circumference of the waterer's lip is important. Minimum lip length (space) is given below. Measure the lip available to the birds -- when chickens use both sides of a trough, the lip available is twice the length of the trough. Additionally, the volume capacity of the waterers must be sufficient to meet the daily requirements of the chickens.

Minimum Water Space Requirements -- 100 Birds

<u>Age in weeks</u>	<u>Daily consumption</u>		<u>Space required (length)</u>	
0 - 1	2 liters	0.5 - 1.0 gal.	0.7 m	30 in.
2 - 4	8 "	2.0 - 4.0 "	1.0 "	40 "
4 - 9	15 "	4.0 - 8.0 "	1.5 "	60 "
9 or more	19 "	5.0 "	2.0 "	80 "
Layers	36 "	9.5 "	2.5 "	100 "

Very Important Note: In hot, dry climates, chickens may consume up to four times the above volumes of water. Therefore, watch the water consumption carefully. You may need to increase volume capacity. Never allow chickens to run out of clean water.

Waterer design -- The simplest waterer is a tin can inverted into a soup or pie plate, or

the bottom of a larger tin can. Punch a hole about 2 cm (3/4 in.) from the open end of the tin can. Fill the can with water and cover it with the plate. With one hand on the plate and one on the tin can, quickly invert both. The position of the punched hole and the vacuum in the tin can will regulate the water level in the plate.

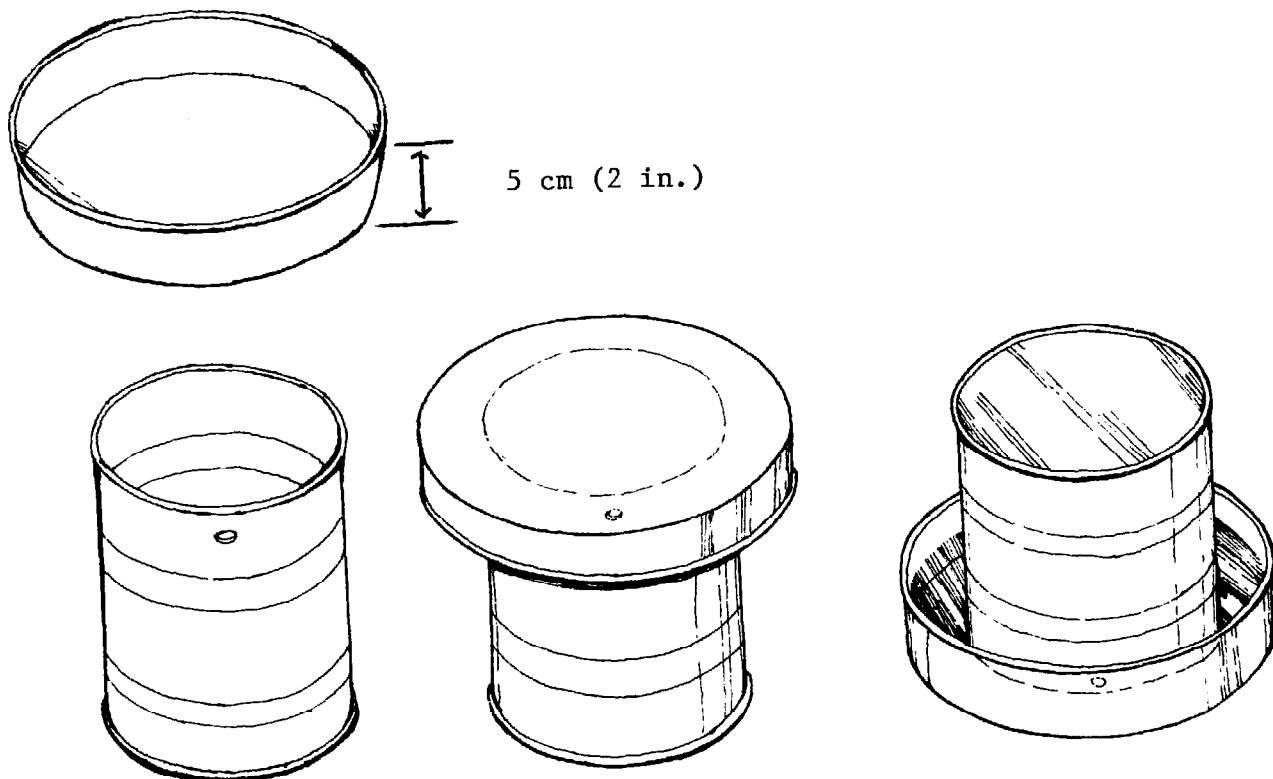

Inverted Waterer

Here are some other possible designs for waterers.

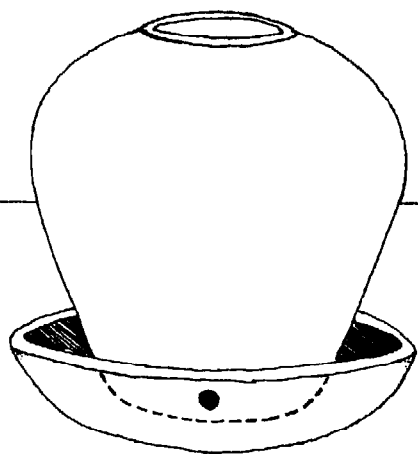

CLAY POT  
with hole or groove in lip

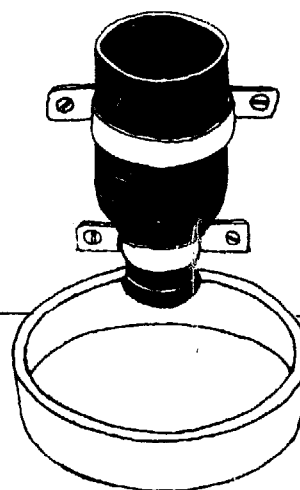

REMOVEABLE BOTTLE  
Strapped to Wall or Stand

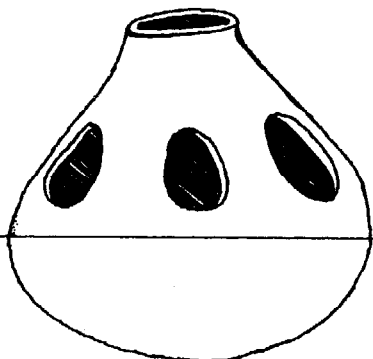

GOURD  
Cut holes in sides and  
sink into ground for stability.  
Not for chicks.

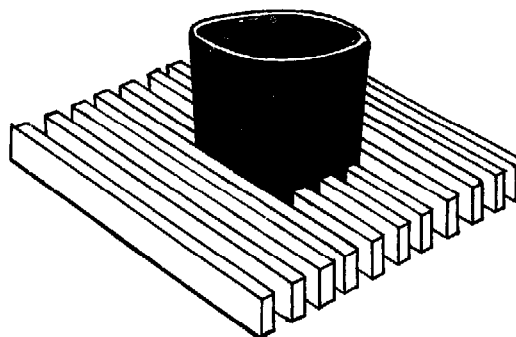

BUCKET  
Set into slatted platform.  
Not for chicks.

Other Waterers

Automatic waterer -- Fit a large, clean oil drum with a faucet or other type of valve and a tight cover. Set the drum on a 1 m (3 ft.) stand of blocks, bricks or reinforced clay mud either inside or outside the chicken house. Run a hose or pipe from the faucet to one end of a galvanized sheet metal trough about 10 cm (4 in.) high and 12.5 cm (5 in.) wide. The length of the trough depends on the size of the flock; a 1.2 m (4 ft.) trough

will serve 100 birds if they drink from both sides. Level the trough on flat rocks, wood blocks, etc., so that the lip of the trough is as high as the birds' backs. Fit an overflow hose or pipe 5 cm (2 in.) above the bottom of the trough in the side opposite the incoming water. Run the overflow pipe outside the house to a place where overflow water will not run back into the house. Adjust the faucet or valve so that the overflow

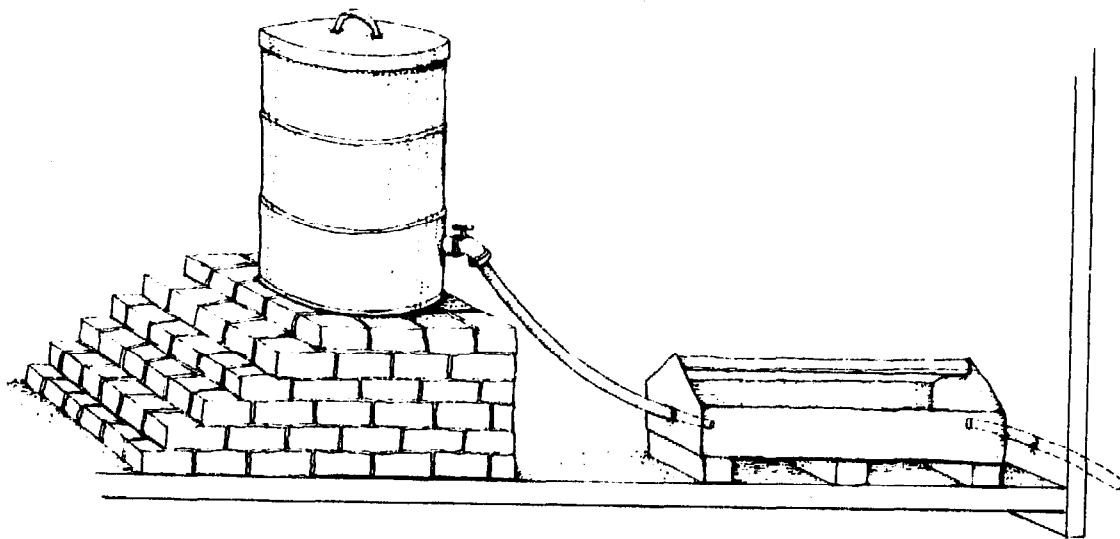

Automatic Watering System

of water is minimized. Protect the trough from contamination by birds, using a spinner (a bar that rotates so chickens cannot roost on it), or constructing a cover over it.

increased (see p. 106).

- Chickenproof -- Birds can't get into or roost on it (using a spinner).
- Efficient -- It should have a lip to prevent birds from "beaking" feed out onto the floor.

## Feeders

A well-made feeder is:

- Durable -- It must withstand frequent cleaning.
- Stable -- It should not tip over when bumped by farmer or chickens.
- The correct height and depth -- As birds grow, the feeder height and depth should be

Distribute feeders evenly throughout the chicken house. No feeder should be more than 4.5 m (15 ft.) from a waterer. Adjust the height of the lip of the feeder to a level even with the backs of the birds. This will help prevent them from scratching contaminated litter into the feeders. In fact, the more they

depending upon the size of the feeder, the lips should measure 1/4 - 3/4 in. (1/2 - 1 1/2 cm).

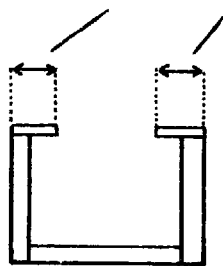

wood

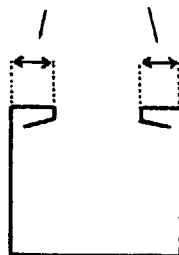

sheet metal

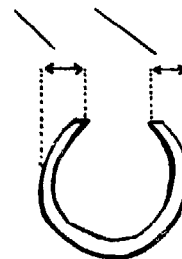

bamboo

### Feeders with Lips to Prevent Waste

have to stretch their necks to reach feed, the less feed will be wasted.

Except for the first three days with day-old chicks, feeders should not be filled more than half full, as feed will be wasted. One-third full wastes even less feed, but feed has to be supplied more often.

To reduce spoilage and mold problems try to adjust amounts of feed supplied so that the birds finish it at sundown. This will take practice. Supply the feed regularly at sunrise and about 2 p.m.; more frequently if the birds empty the feeder.

When feeding chickens supplemental vegetable matter, don't throw it on the floor -- suspend it at beak level with a rope, put it in a hanging net, or place it in a wire or slatted hopper, a feeder made out of wire mesh.

Feeder space (length) -- As with waterers, feeder space is the linear distance of lip available to the birds -- either the circumference of a round feeder tray or twice the length of a trough if the birds feed from both sides. Minimum space and depth requirements are given below.



Feed Requirements for 100 Chickens

Age in weeks	<u>Daily consumption (will vary)</u>				<u>Suggested Feeder depth</u>		<u>Space required (length)</u>	
	<u>Meat birds</u>		<u>Layers</u>					
1	1.8 kg	4 lbs.	1.4 kg	3 lbs.	5 cm	2 in.	2.5 m	100 in.
2	2.3	5	1.8	4	"	"	"	"
3	4.6	10	2.7	6	"	"	"	"
4	5.0	11	3.2	7	8.9	"	3.8	150
5	6.8	15	4.1	9	"	3-1/2	"	"
6	7.3	16	5.0	11	"	"	6.1	240
7	8.2	18	5.5	12	"	"	"	"
8	8.6	19	6.4	14	"	"	"	"
9	9.5	21	6.8	15	"	"	9.6	380
10	10.5	23	7.3	16	12.5	5	"	"
11	11.4	25	7.7	17	"	"	"	"
12	13.2	29	8.2	18	"	"	"	"
13	14.1	31	8.2	18	"	"	"	"
14	15.9	35	8.6	19	"	"	"	"
15			9.1	20	15	6	12.7	"
16			9.5	21	"	"	"	"
17			10.0	22	"	"	"	"
18			10.0	22	"	"	"	500
19			10.0	22	"	"	"	"
20			10.5	23	"	"	"	"
21			10.5	23	"	"	"	"
22			10.9	24	"	"	"	"
23			11.4	25	"	"	"	"
24			11.4	25	"	"	"	"

Feeder design -- This wooden trough feeder is designed for layers 15 or more weeks old. Dimensions of intermediate feeders should be adjusted for the age and size of the birds (see feed space requirement table).

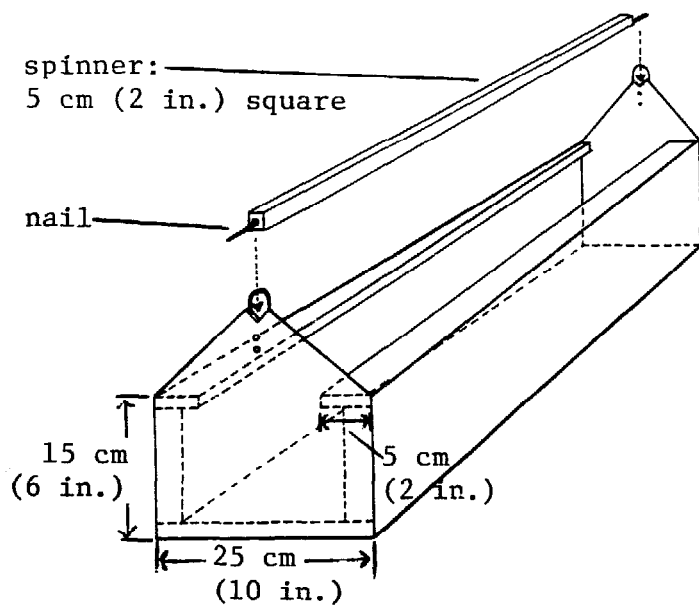

Wood Feeder

A spinner is made from a rod of wood with a metal rod attached to each end so it is able to rotate. The metal rod can simply be made from a nail by cutting off its head.

Bamboo feeders -- Bamboo can be used for inexpensive feeders. To keep the birds out, use a spinner, or tightly wrap the feeder with wire, as shown below.

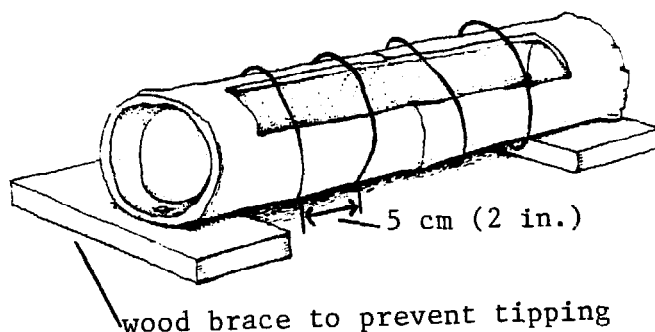
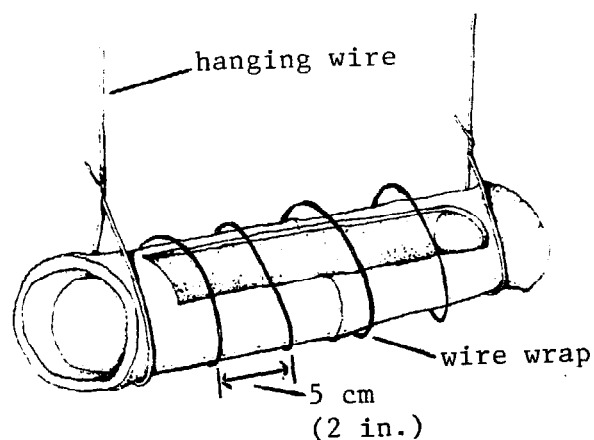

Bamboo Feeders

Dimensions depend upon the number and size of birds.

Hanging feeder -- Hanging feeders have several advantages, including: rats have difficulty getting into them; they continuously supply feed at the proper height; it is easy

to adjust their height. They can be made from large tin cans (sometimes available from restaurants), or from sheet metal.

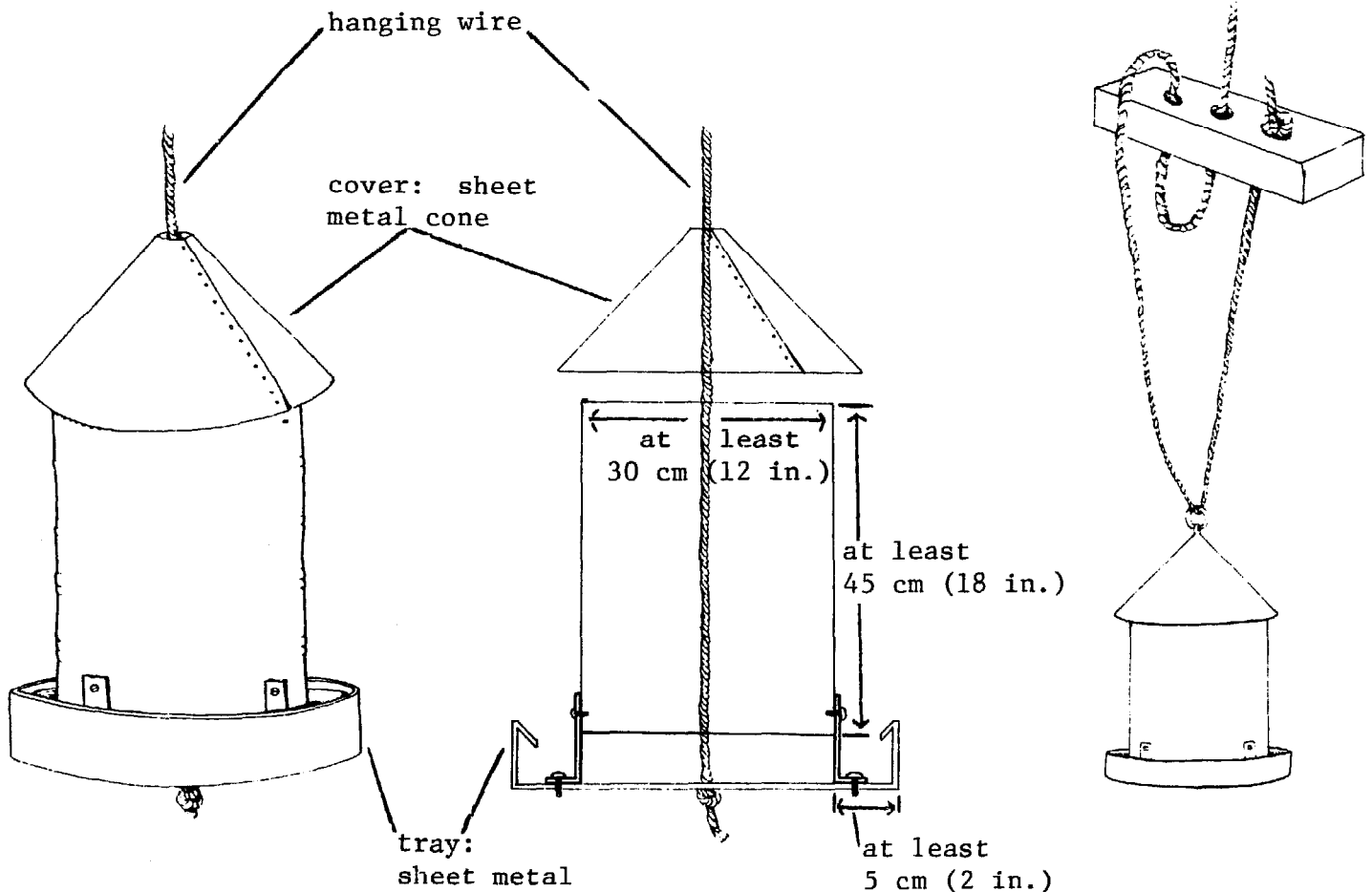

Hanging Metal Feeder -- Such a feeder with a tray of 40 cm (16 in.) in diameter is sufficient for 10 mature layers.

## Grit Hoppers

Instead of teeth, birds have a muscular organ, the gizzard, to grind their food. To crush food well, gizzards must contain hard, small stones, or grit. Over time, the grit crumbles or dissolves and must be replaced. Country chickens, ranging free or in fenced-in yards, usually can find their own grit, but the farmer must supply grit to contained birds.

Good grit stones are about the

size of small peas and have a rough surface. Small river gravel that is not smooth is excellent grit. Relatively inexpensive grit can be bought from commercial feed suppliers. Grit can be served in any container that the chickens can't enter and contaminate. A grit hopper that can supply 200 chickens for about a week is illustrated below. Keep the cover closed so the grit remains clean. Make sure grit always is available or the chickens will not digest their feed well.

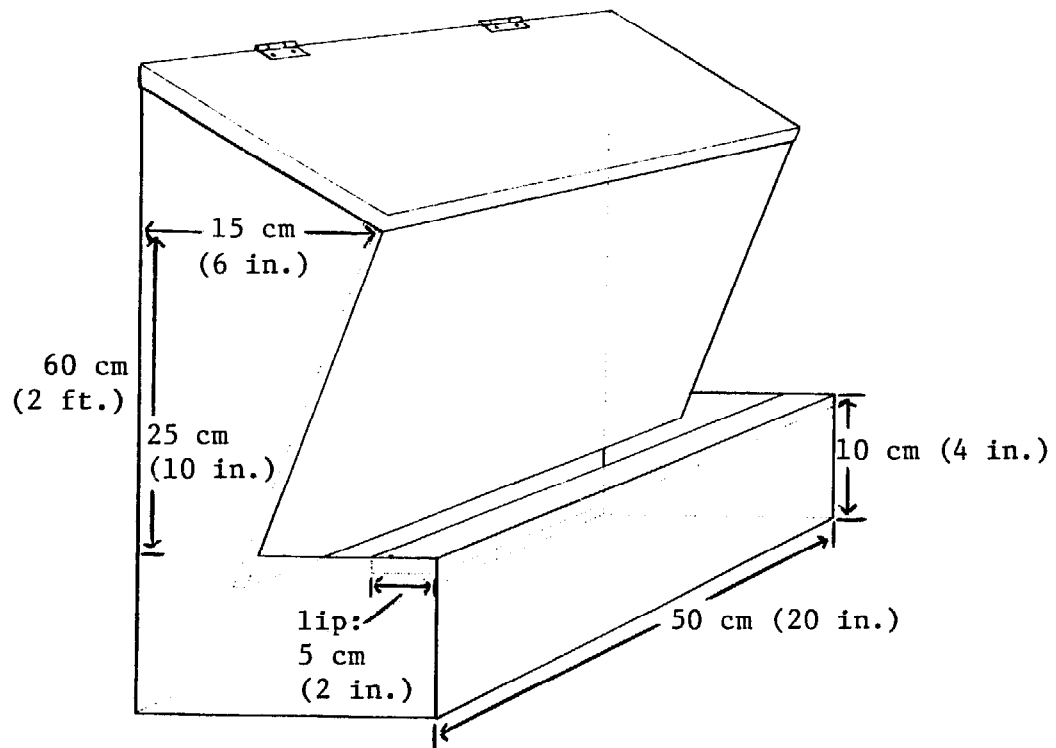

Grit Hopper

## Oyster and Egg Shell Hopper

Chickens need a source of calcium to maintain their bodies, and laying hens need extra amounts to produce strong egg shells. The usual calcium source is crushed oyster shell or limestone, purchased commercially. Powdered limestone does not work well because hens do not like to eat it. This can be supplemented with boiled and dried egg shells broken into very small pieces so that the hens don't recognize what they are eating and

start to eat their own eggs. The egg shells from a flock do not provide enough calcium to meet that flock's requirements. Keep a calcium supply always available and the chickens will take what they need. Old hens require more calcium than young ones. Also, hens need more calcium in hot weather.

A calcium source can be included in a mixed feed, or provided separately in a container similar to the grit hopper. It may be convenient to use a two-compartment hopper for grit and calcium, as shown below.

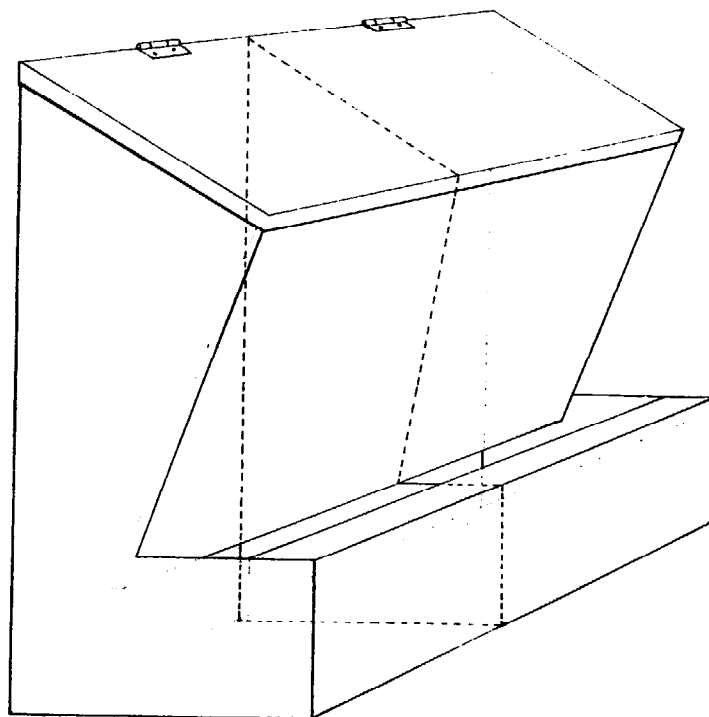

A Two-compartment Grit and Calcium-source Hopper

## Nests

Providing nests for laying hens helps keep eggs clean and reduces breakage. Baskets, reinforced with sun-baked clay or cow dung, can be used for nests (see below). Usually clay is applied to the outside of the basket. Nests should be placed on the darkest side of the house, preferably where the morning sun will not hit them. Line them with fresh litter and keep it clean. Provide one nest for every five hens. In hot climates, nests should be well-ventilated.

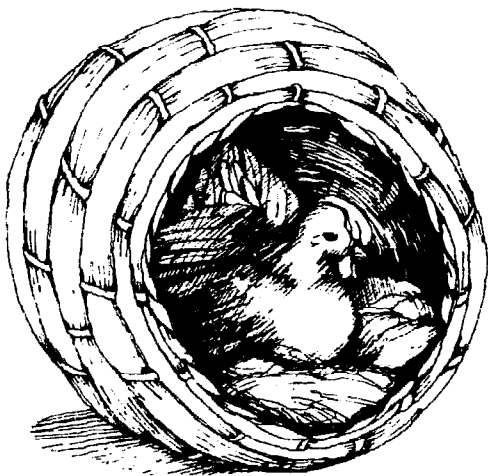

Nesting boxes -- With more than a few laying hens, the farmer probably will find that it pays to provide specially constructed nesting boxes. The concept is to enclose a volume of space about 0.028 cubic m (1 cubic ft.) per bird with wood, sheet metal, wire mesh, clay or mud bricks, woven mats, etc., and line it with litter. Well-constructed boxes will stand up to frequent cleaning.

Boxes may be placed on the floor, raised by supports or attached to the wall. A set of boxes may have one, two or three tiers. Any boxes above the floor should provide a perch in front where birds can alight before entering the nest. Ideally, there should be a means of closing the nests in the evening so that birds don't roost in and dirty them.

Two types of nest boxes could be used:

- Individual nest boxes are constructed so that only one hen will be able to fit in one compartment at a time.

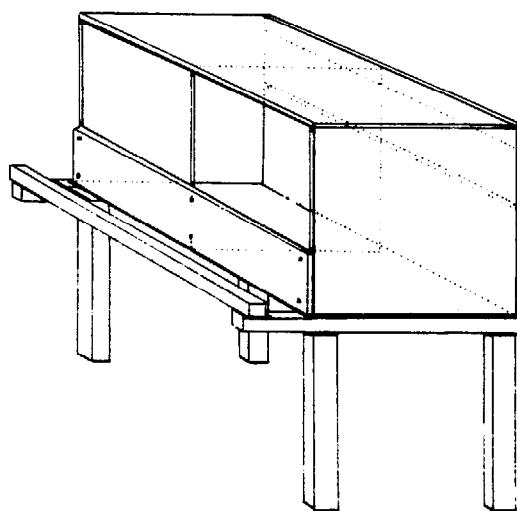
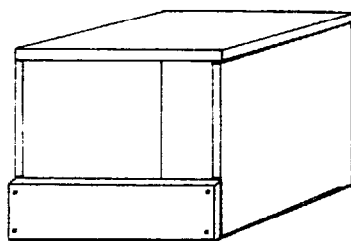
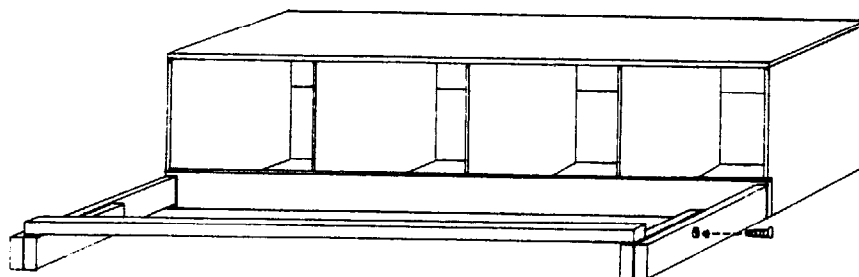

### Individual Nest Boxes

- Colony nest boxes are constructed large enough to allow four or more hens to lay at one time (4 sq. ft.

or more of floor space without dividers). These are not recommended because more eggs will be broken than with individual boxes.

## Roosts

When they can, chickens prefer to spend the night roosting in trees. Contained birds don't need roosts, but the presence of roosts can help concentrate droppings, making sanita-

tion easier. Building roosts takes time and money. If you use them, place a removable droppings board under them or screen off the area beneath. Clean the boards or the screened area often. Allow 20 cm (8 in.) of roost for each bird.

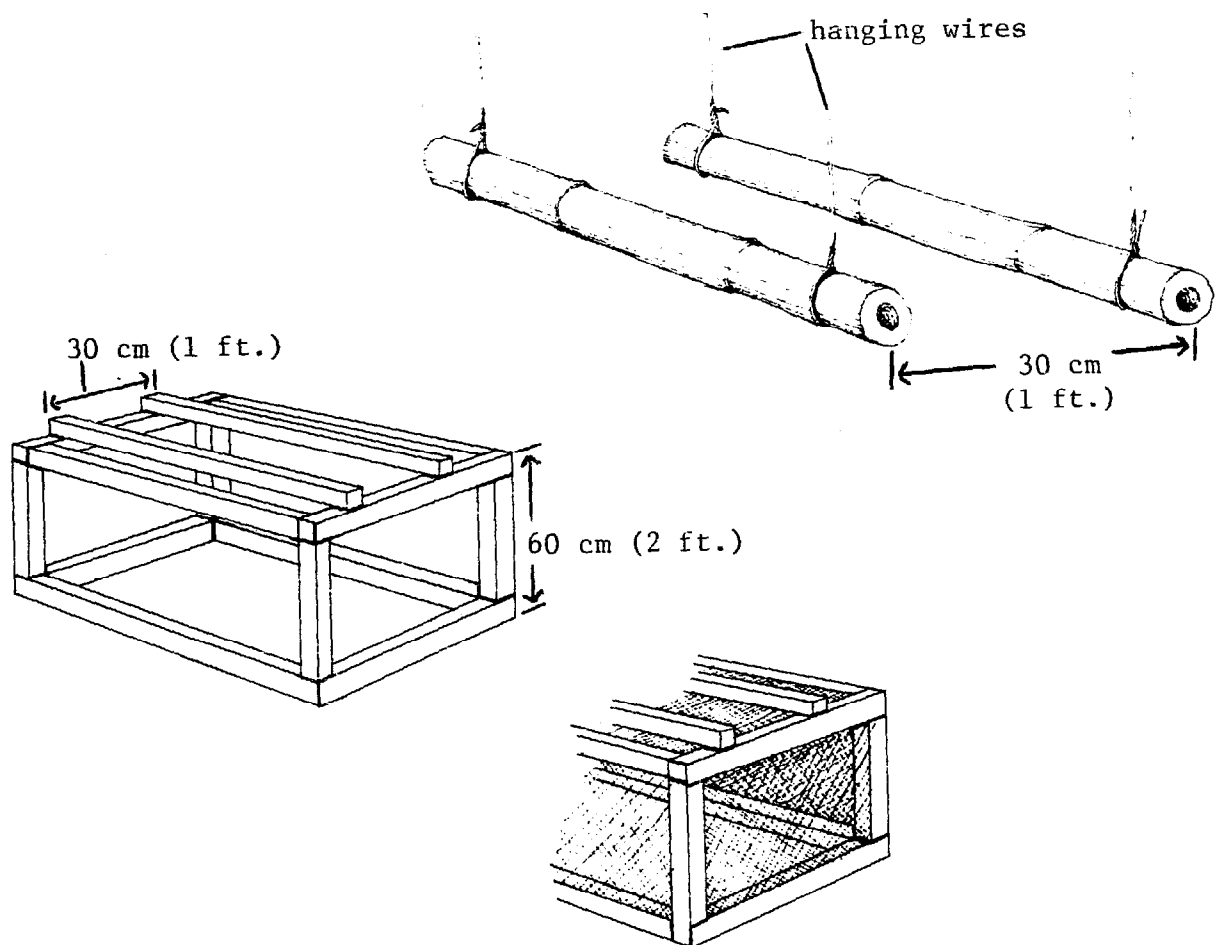

## Roosts



# 7. Keeping Chickens Healthy

Chickens are subject to as many ailments as humans are. Some chicken and human diseases even have the same names: pox, colds, cholera, typhoid, hepatitis, pneumonia, bronchitis and so forth. Parasites, such as tapeworms, ticks and lice, and poisonous substances such as aflatoxin and botulism attack chickens as well as humans. A well-trained veterinarian, backed by a competent laboratory, can identify most chicken diseases with a good degree of certainty, but even then often can't prescribe effective treatment, because some diseases cannot be treated, only prevented.

So what hope is there for small farmers and extensionists who don't have the veterinarian's experience and equipment? Plenty. Good management of chickens, with special attention to sanitation, quality of feed and vaccinations greatly reduces the chances of diseases or parasites attacking the flock. Know-

ing about major health problems and how to treat them is important--but not as important as preventing these problems in the first place.

Even with good management, of course, health problems can occur, and the farmer should be alert for them. A sick chick is inactive, doesn't stand erect and may have runny eyes or dried traces of diarrhea around its vent. It may sleep in an odd position or walk with a strange gait. Older sick chickens show obvious signs of poor condition: thin, hunched body, scraggly feathers, wings hanging loosely, general weakness and smaller size than the healthy members of the flock (assuming that the flock is all the same age and breed, which is strongly recommended). Two major signs of health problems in a flock are if total feed consumption decreases, or if mortality exceeds one percent in any seven-day period. Observe your flock for deviations

from normal for at least 15 minutes each day.

Even in a well-managed flock you can expect to lose an average of one percent each month. In other words, if you start with 100 chicks, you should expect to have about 90 left at the end of a year. Some will die suddenly; others will show obvious signs of disease. Remove sick and dead chickens.

For small flocks of less than 50 chickens, use an isolation pen for the period of sickness. For larger operations, slaughter sick birds and perform a post mortem examination to see if the cause of sickness can be determined.

If mortality exceeds the one percent rate or if there are more than one or two sick chickens in a flock of 100, seek veterinary advice immediately.

Bury all dead chickens in a pit in the ground to eliminate any chance of disease transmission from these chickens. A dead bird disposal pit should have a tight cover to prevent predators such as rats from getting at the chickens. If

the farmer has a methane gas digester, dead chickens can be put in this, but feathers will have to be removed first because they do not digest for many months. If this is done, burn the feathers.

## Diseases

The innumerable diseases that can affect a chicken may be divided into three categories:

- Those prevented by locally recommended vaccines (such as Newcastle).
- Those prevented by or treated automatically in a good management schedule (such as coccidiosis).
- Those for which good sanitation and nutrition are the best means of prevention (such as cholera or coryza).

### Prevention by Vaccination

Before doing any vaccinations, you should become familiar with what diseases are prevalent in your area or you may needlessly vaccinate for

a non-existent disease. Check first with local authorities. A vaccine, which contains bacteria or viruses introduced into the body to produce immunity to a specific disease by causing the formation of antibodies, can be administered to chickens in a number of ways (see below). Handle the birds swiftly but smoothly to minimize stress, but be sure that all receive the proper dosage.

Be extremely careful with vaccines--they can kill birds. Store them according to directions; many need refrigeration. Mix them away from poultry just before using. Don't spill them on or near chickens. When working with large numbers of birds, have adequate help--the person mixing and giving the vaccines should not handle the birds, if possible. If you are using a live virus vaccine, tell neighboring farmers because if they have not already vaccinated their birds, the live virus could spread the disease to their chickens. If one farmer vaccinates and the next doesn't, be certain there is no means of transmitting the disease to

non-vaccinated birds. Don't give more vaccine per bird than recommended, and don't give less--stretching vaccine supplies is dangerous. Administer mixed vaccine at once and get rid of the remainder--don't keep it overnight as it will lose its effectiveness. Thoroughly sterilize your equipment if you plan to use it again (it is best to dispose of it and use new equipment). Change your clothes and disinfect your shoes before visiting other chickens.

Methods of vaccination include:

- Medicine or eye dropper--Put a drop of vaccine in the bird's eye and wait for it to blink, or place a finger over one nostril, put the drop in the other nostril, and wait until the drop is breathed in.
- Feather follicle--Pull a few feathers from the bird's thigh and rub the feather follicles in the area with a vaccine-soaked cotton swab or brush.
- Wing web stick--Dip a web stick into vaccine and use it to puncture the skin on the underside of a wing. Be careful not to hit a blood vein. Always stick the same wing of all birds (either the left or the right wing) so that you can check later on for a scab

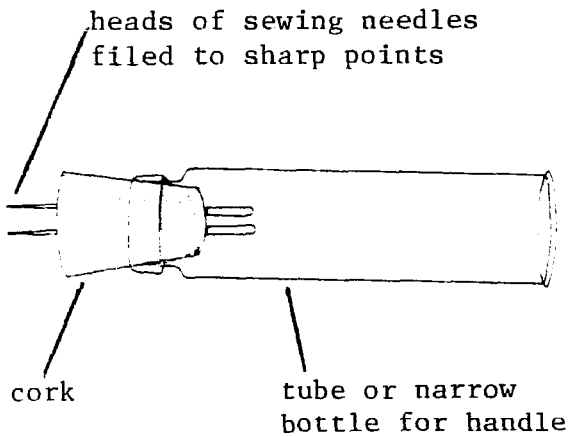

### Wing Web Stick

which shows the vaccine has been effective, or "a take."

- Drinking water--Some vaccines are mixed into the flock's drinking water.
- Intramuscular--Use a syringe to inject the vaccine into the breast.

### Diagnosis

Other than knowing the obvious symptoms of the most common chicken diseases and what to do about them, an inexperienced farmer should be very cautious about diagnosing a

disease and attempting to cure it. Seek professional advice whenever possible.

### Newcastle (Ranikhet) Disease

Newcastle is the disease most widely feared by poultry farmers around the world. When it strikes young chickens, mortality may be as high as 100 percent. In parts of Asia, it is known as Ranikhet Disease.

Cause--Virus transmitted by other chickens and other species of birds.

Symptoms--Coughing, gasping and raspy breathing and/or extreme

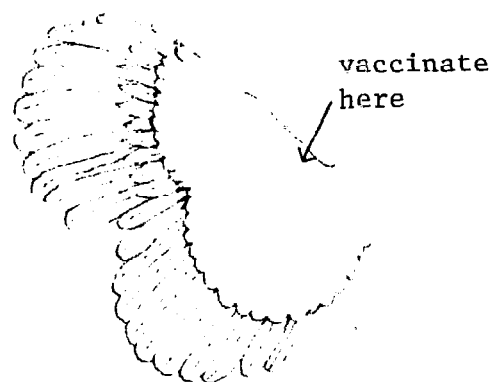

### Puncturing the Wing Web

nervousness, and distended crop. Inactivity, uncoordination, drowsiness, huddling near heat source, drooping head, partial paralysis, coma, death. The presence of all these symptoms does not confirm the diagnosis --only lab tests can do that. Newcastle quite often appears as a respiratory condition before a nervous condition appears.

Post mortem signs--Mucus in trachea, possibly yellow and thickened air sacs; possible hemorrhages in proventriculus.

Treatment--None.

Prevention--Most countries have vaccines available. A general rule of thumb used by many poultry experts is to vaccinate on a 4-4-4 schedule, meaning at four days of age, four weeks, and four months. But you should use local recommendations.

#### Fowl Pox

Fowl pox is a disease that attacks birds when they are three to five months old. It is not neces-

sary to vaccinate for this illness before the chicks are five weeks of age. Pigeon pox vaccine is only needed to provide emergency treatment if there is an outbreak of fowl pox in a non-vaccinated flock.

Cause--Virus spread by insects, especially mosquitoes, and then by direct contact with infected chickens and wild birds.

Symptoms--Fowl pox most frequently attacks birds when they are three to five months old.

There are two types:

- Dry pox or modular form, which generally appears as a wart or insect bite. Causes swelling of comb, wattles, face and sometimes eye. By itself, dry pox doesn't usually cause much mortality.
- Wet or diphtheritic form begins with discharge from eyes and nostrils, then a cheesy material forms in the mouth. This can cause suffocation unless it is removed. Wet pox results in high mortality--up to 50 percent--and egg production in layers decreases substantially.

Post mortem signs--Mucus in trachea, possibly yellow and thickened air sacs, hemorrhages in the proventriculus.

Treatment--In an affected flock: if the birds have been observed daily, this disease can often be detected before many birds are affected. In this case, vaccinate the unaffected birds with fowl or pigeon pox vaccine immediately.

If a neighboring flock gets the disease, vaccinate all flocks in the area immediately.

There is no treatment for chickens already having fowl pox.

Prevention--Follow the recommendations of local authorities.

In most cases this means:

- If fowl pox is prevalent in an area, the best action is to vaccinate. Many experts suggest vaccinations around the sixth week of age and again at 12 weeks.

#### Fowl Cholera

Cause--Bacteria spread by droppings of infected birds through contaminated soil, feed or water. Vectors include wild birds and the feet of people and animals.

Symptoms--There are two types

of cholera which affect chickens:

- Peracute or severe cholera: the only symptoms are dead birds.
- Acute and chronic: sudden, almost total lack of appetite; greenish-yellow diarrhea; difficulty in breathing; high fever and increased thirst; head turns blue; enlarged, hot, swollen combs and wattles; affected birds feel very hot; swollen eyes and thick discharges from nasal passages similar to that found in coryza.

Treatment--A recommended bactericide (sulpha drugs) in feed and water may reduce mortality in an infected flock. Remove affected birds and change litter. Thoroughly disinfect equipment and house.

Prevention--Primarily, cleanliness. If vaccines are recommended, it may help to administer them in accordance with the recommendations of local authorities.

#### Infectious Bronchitis

Cause--Virus spread through air or via contaminated material.

Symptoms--Chicks: sneezing,

gasping, mucus, clicking heard in throat, discharge from nostrils and eyes. Layers: egg production drops abruptly by 10 to 50 percent, remaining production poor quality (thin shells, misshapen, watery whites). In chicks, mortality may be 5 to 60 percent; in mature birds, zero to two percent.

Treatment--None for the infection. Antibiotics can be given to lessen complications.

Prevention--Following nearby outbreaks, vaccines, if recommended by local authorities, can be used in accordance with their recommendations and schedules.

#### Laryngotracheitis

Cause--Virus, airborne or carried on clothing and equipment from infected birds.

Symptoms--Birds have extreme difficulty breathing, may stretch their necks when inhaling and droop their heads on their chests when exhaling, also may cough up bloody mucus.

Mortality may range from 5 to 50 percent.

Treatment--None for the infection, but disease spreads slowly, so unaffected birds can be vaccinated.

Prevention--Never vaccinate where there is no history of the disease. If an outbreak occurs nearby and vaccine is available, use the schedule and methods recommended by local authorities.

#### Marek's Disease (Leukosis)

Cause--Virus spread through chicken dander (cells sloughed from feather follicles), the major component of chicken house dust.

Symptoms--Droopiness, poor feathering and weight loss may be the only signs before death. Some birds are mildly to completely paralyzed; they lie on their sides and slowly starve. Mortality may be up to one percent per day for two to three weeks.

Treatment--None.

Prevention--Vaccination of day-

old chicks--usually done by the breeder, if done at all. Vaccinated egg-breed chicks are especially valuable.

#### Pullorum

Cause--Salmonella bacilla transmitted through the eggs from one generation to the next if parents are not salmonella-free. Can also be transmitted through visitors' feet, animals, contaminated feed, equipment, and wild birds.

Symptoms--Chicks: sudden deaths, other chicks droop wings, huddle near heater. Diarrhea is white, sticky and foaming. Chicks may have 50 percent mortality. Adults: in acute outbreaks are weak and depressed, may have greenish-brown diarrhea.

Treatment--Sulfa-based drugs for market stock; do not use infected birds for breeding.

Prevention--Buy only certified pullorum-free chicks and implement sanitary management practices.

#### Coccidiosis

Cause--Nine species of coccidia (protozoan parasites) spread through contaminated food, water or litter. Each species attacks a different portion of the intestines or ceca, an intestinal appendage. It is extremely difficult to isolate chickens from coccidia.

Symptoms--Signs of the disease will vary with the type of coccidia involved and the degree of immunity the flock has to that type. General indications are: decrease in food consumption; birds hunch backs, droop tails and ruffle feathers. Diarrhea may start and the loose droppings may be bloody (reddish brown). Following bloody diarrhea, mortality may increase rapidly.

Post mortem results--In chickens less than 16 weeks old, red specks on interior wall of intestines (in severe case, purple spots show through exterior wall). Intestinal wall thicker than normal. Other signs:



gray-white streaks on wall of upper intestine, pink or reddish substance on intestinal wall. In chicks (under nine weeks) ceca may be filled with blood and swollen to the size of a finger. For birds older than 16 weeks, a lab test is needed.

Treatment--If a confirmed outbreak among chickens one to twelve weeks old is severe, treat immediately with locally recommended coccidiostats.

Prevention--There are three ways to deal with coccidiosis.

- Natural development of immunity--Allow the flock to build immunity without administering any drugs unless there is a severe outbreak. This works well when the flock is exposed only to low levels of coccidia. Under very dry conditions, there may not be enough infection present to develop immunity. In a very dry environment, sprinkle the litter with water at weekly intervals to maintain a constant exposure and immunity level in the flock. This may be necessary where a well-ventilated poultry house is located in an area where the humidity level of

the outside air is consistently under 50 percent. Sudden, massive invasions of coccidia can hurt the flock severely, and large doses of medication can prevent future immunity.

- Complete prevention--Give the flock the recommended medium level of coccidiostat through its first 15 weeks. This most likely will prevent the birds from contracting coccidiosis at all, but they won't develop immunity either. Use this method only for broilers and for layers that will be kept in wire cages.
- Immunity plus treatment--Use the low-level dosage recommended during the first 15 weeks. This should allow the birds to develop some immunity, and they may not need any further attention. In case of a mild outbreak, treat broilers and layers going to cages with the largest recommended dosage. Treat layers that will be kept on litter with heavy doses only during severe outbreaks so that they otherwise build up as much immunity as they can. This method is the safest overall, and would be the best single recommendation for small- and medium-sized flocks.

Coccidiostats--These drugs come in many forms, many combinations and under many names, both generic and proprietary. It's a good

idea to switch from one type of drug to another each chicken cycle so that local coccidia do not establish resistance to any particular one. Don't mix one with another--it may be harmful. Follow manufacturer's directions closely.

Some effective coccidiostats are: amprolium; amprolium plus ethopabate (not for laying chickens); arsenobenzine, stop use five days before slaughter; glycarbylamide (not for laying chickens), stop use at least four days before slaughter; dinitrodiphenyldisulfide; nicarbazin, stop use four days before slaughter; aklomide, stop use at least five days before slaughter; bithionol and methiotriazamide, stop use at least five days before slaughter; 3,5, dinitro-o-Toluamide (not for laying chickens); and sulfaquinoxaline. Other drugs that can be used as coccidiostats, though not as effective as those above, include: terramycin, nidrafur, agrimon,

3-Nitro, NF-180-furazolidone, nitrofurazone, phthalysulfacetamide (TSC), and sulfaethoxyypyridazine (SEZ).

#### Infectious Coryza (Cold)

Cause--A bacteria, spread from chronic or acutely infected birds to healthy birds.

Symptoms: Foul-smelling discharge from eyes and nostrils; coughing; sneezing; difficult breathing; chicks shake their heads as if trying to get rid of something; often found where different ages of birds are kept together and birds are overcrowded. Rare in adults, but when found, egg production drops, feed consumption decreases. Mortality rare.

Treatment--Sulfa drugs in the feed or water will eliminate the problem within two weeks if other diseases or complications are not present.

Prevention--Do not mix birds of different ages: cull all birds found with swollen head parts before they infect the rest of the flock; there may be bacter-

ins or vaccinations available in some countries, but not most. Use proper management practices.

## Parasites

Parasites, both internal and external, weaken and can kill chickens. In addition to getting its food from a chicken's body, a parasite also can carry disease or increase the bird's susceptibility to disease.

### Worms

At least nine species of worms may infect various internal parts of chickens. Chief among them are roundworms, cecal worms and tapeworms. Worms are spread through feces or through a variety of intermediate hosts, including snails, slugs, earthworms, flies, cockroaches and other insects.

Symptoms--Initial increase in feed consumption with little or no weight gain. In severe cases, chickens lose weight rapidly. Laying chickens produce fewer eggs.

Post mortem results--Large

roundworms, found in middle of small intestine, are yellow-white, from 4 to 7.5 cm. (1 1/2 to 3 in.) long, and comparatively thick-bodied. Cecal worms, found in blind ends of the ceca, are white and about 1.25 cm. (1/2 in.) long. Tapeworms, found in the small intestine, are flat, white, ribbon-like and segmented. They vary in size from microscopic to 15-17.5 cm (6 to 7 in.).

Treatment--Each type of worm requires a specific drug: piperazine for roundworms, phenothiazine for cecal worms and dibutyltin dilaurate for tape worms. Some manufacturers combine one or more of these drugs in a single medication. Treat as directed for major infestations.

Prevention--Primarily, sanitation. Make sure that litter is replaced between flocks, keep wild birds out of the house, use insecticides against cockroaches and other intermediate hosts and do not feed snails or

slugs to chickens. If you suspect that worms are present (they probably are), treat broilers at four weeks of age and every two months thereafter; layers at ten weeks and every two months thereafter.

### Lice

The most common poultry parasites are lice. They spend their entire life cycle on the body of the bird.

Symptoms -- Skin irritation, scabs, ruffled feathers, diarrhea, small weight gains or decrease in egg production, some dead young chickens when infestations are heavy.

Treatment -- Infested chickens on raised floors, in cages or ranging free should be sprayed or dusted with malathion, carbaryl, pyrethins, naled, coumaphos or similar preparations, using a crop sprayer. In deep-litter systems, the litter and all equipment except feeders and waterers can be sprayed or dusted. Where chemicals are too expensive or not available, some

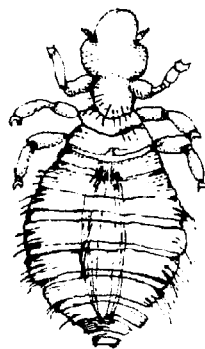

### One Kind of Chicken Louse

farmers use a mixture of ashes with sulphur powder or gun powder obtained from the local market. About 20 grams of sulphur powder to 1 kg of cold ashes or a 1:50 ratio is said to be quite effective.

Prevention -- Keep nests clean. If you use roosts, paint them with nicotine sulfate -- the bird's body heat will create fumes that kill the lice. Some use creosote in the cracks and joints of roosts (carbolineum).

### Mites

Mites are almost invisible, spider-like creatures that come in var-

ious species. Some stay on the birds continuously, while others attack only at night.

Symptoms--Scaly leg mite: birds lame, legs swelling, scaly and crusted. Red mites (nocturnal): loss of weight and egg production, anemia. Depluming mites (base of feathers): birds pull feathers out to relieve itching.

Treatment--None for scaly leg, cull affected birds. For other mites, same treatment as for lice.

Prevention--Same as for lice.

#### Ticks

In addition to sucking blood, fowl ticks (flat, egg-shaped, reddish-brown bugs), can carry spirochetosis. Spirochetosis, or tick fever, results in rapid death without any other symptoms. Usually, ticks are found only in hot, dry areas. They spend part of the time in cracks in walls, roosts, and other wooden equipment and are very hard to find. If you suspect their presence, pry into cracked boards with a knife and examine closely.

Symptoms--Loss of appetite and

weight, possible anemia.

Treatment--Same as for lice, then aggressively attack infestation, removing litter and equipment, feeling in cracks in feeders and elsewhere for ticks, cleaning and spraying everything, and repeating that twice at two-week intervals and once six months later. If the roof is thatch, change it. If the house is old, consider building a new one. Some farmers go over cement and other non-inflammable materials with a blowtorch.

Prevention--Sheet metal feeders, nesting boxes and other equipment are easier to keep free of ticks than wooden ones. Roosts hung by wire are safer than those on stands.

## Other Health Problems

Feed that is improperly stored or kept too long can go bad, causing botulism or other food poisoning. Be very careful around chickens with insecticides, rat poisons, gasoline (petrol) engines and other possible poison sources. Crowded or improperly cared for chickens may start pecking each other.

## Performing a Post Mortem Examination

Looking carefully at the body and insides of a chicken that has died of unknown reasons may help discover those reasons. Very sick birds, with no hope of recovery, should be killed, using locally approved methods, or by dislocating their necks.

It will be helpful to examine the insides and outsides of as many healthy chickens as you can when they are slaughtered. Note the position, size, color and texture of all internal organs. Then, when you work on a sick bird, you will be better prepared to spot abnormalities.

This manual will not attempt to give instructions on how to diagnose most diseases--that is best done by special publications with color illustrations--but there are some signs you should look for.

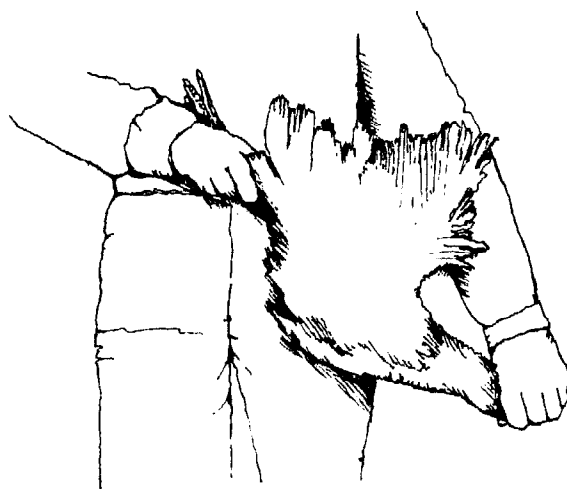

Killing a Chicken. Stretch neck and bend back around thumb.

Examine a bird as soon after death as possible, before body conditions have changed. As you work, take good notes. They will help veterinarians or lab technicians, if they are available, to identify the problem. Ideally, you would take or send a few sick but still living chickens to the vet or lab for diagnosis, but this often is impractical.

In a post mortem, first examine the outside of the bird. Look for lice or mites, particularly around the vent, that may have contributed to the death. Discolored head parts, such as the comb and wattles, are indications of a number of diseases. Straighten the neck, pull the tongue and examine the throat and windpipe for cheesy nodules (lumps), signs of pox. Check the nostrils for a putrid smell. If the legs are rough, scaly and swollen, it may indicate mites. Look for swollen leg and wing joints and excessive abdominal fat. Also look for blackened spots which can be caused by scorpion stings.

Open the bird carefully. With a knife or shears, cut through the side of the mouth and esophagus. Look for the lesions (injured areas) of pox, fungus, excess blood or mucus, and other abnormalities and foreign matter and nodules. Slit the larynx and trachea, looking for excess mucus, inflammation, blood and cheesy matter.

To look inside the bird, first slit the skin over the hip joints and dislocate them so that the body lies flat. Puncture and cut the skin from just below the point of the breastbone to the head. Pull the skin flaps aside to bare the breast. With heavy shears, cut through the heavy bones and ribs on both sides of the keel (center ridge of breastbone), and remove the keel and breast muscle. Do this with care or you will damage the internal organs. Check for fluid in body cavity. In females check body cavity for broken egg yolks (a black fluid if broken yolk has been in body cavity for a while).

Slit the crop, remove food (noting if it smells sour), and

examine lining for worms, fungus and other problems. Examine the liver, noting its color (normal is dark brown), and looking for lesions or nodules (soft ones may indicate leukosis). Check the heart for lesions, hemorrhages on the fat, and cheesy matter or fluid inside. Examine the spleen and bronchial tubes for lesions and nodules. Note the color and texture of the lungs (normal, bright red and spongy, will float in water). Look for fluid (pneumonia), tumors, nodules, and congestion (dark red, will sink in water).

Remove the intestines and look for tumors, nodules or hemorrhages. Slit the intestines to check for worms and other problems. Thickened intestinal walls may indicate microscopic worms or coccidiosis. Also look for blood, inflammation and excess mucus. If you find blood in the ceca, look for cheesy matter, scarred lining and cecal worms.

Open the proventriculus (true stomach, located at the joining of the esophagus and gizzard), checking for hemorrhages, worms, or

inflammation. Slit the gizzard, looking for erosion. Gizzard erosion most often is caused by a nutritional deficiency and is indicated when ulcers and/or peeling of the gizzard lining is seen. Check the kidneys for urates (white material) in internal passages. Examine the brachial nerves--if swollen, may indicate leukosis. Note gall bladder size and color (normally green). In layers, check the ovary and oviduct for excess fat and ruptures (breaks) that lead egg yolk into other body areas.



# 8. Feed and Nutrition

For every animal there is an optimum amount and balance of foods or nutrients that will produce peak physical condition, growth rates, and, in the case of chickens, productivity. It is important to understand that both amount and balance are important in attaining maximum productivity. It is not enough to feed a layer all she can eat. A chicken would like to eat a lot of fresh greens and corn because these things appeal to it (chickens can't taste). But, as in the case of humans, what appeals most is often not that which is best for the well-being of the chicken and, in turn, the poultry farmer. Thus, proper nutrition, proper balance and control by the farmer of what the chicken takes in is needed. A frequent mistake in poultry feeding is to feed a nutritionally-balanced feed and then ruin that balance by feeding excessive amounts of fresh

greens, cereal grains, etc., on the side. This practice is all right if the feeding program includes these items in formulating the final balance.

Because chickens have a short life cycle and are easily contained, many scientists have studied how various diets affect them. Much has been learned--too much to cover in this manual.

In improving breed operations, the chicken farmer will most likely spend more money on feed than on everything else in the operation combined. For this reason, it is important that care be taken in choosing a feeding plan. There must be an assured source of good feed for the birds, either locally grown or commercially prepared. Commercial feeds are the easiest to work with. In some remote locations they may be too expensive or simply not available. Where commercial

feeds are available and being used successfully by some farmers, they are most certainly the choice feed source for all farmers.

The concept of "too expensive" should be explained. The end result of how much profit can be made using a feed is more important than the cost of the feed itself. A steady supply of a well-balanced feed may result in more profit per bird than a feed which is half as costly, but is not always available or is not properly balanced in nutritional content.

If good commercial feed is not available or is too expensive, the next best alternative for improved breed operations is to consider mixing local ingredients (usually energy sources) with a "protein concentrate" and vitamin/mineral mixture. Protein concentrates often are available near urban and coastal areas where they are either imported or mixed locally using fish or other protein sources. These concentrates can be transported to more remote areas and mixed with local maize, rice polish, tapioca, tubers

and other high carbohydrate ingredients.

Finally, the last alternative is to mix feed using only locally available ingredients.

The specific approach taken in meeting nutritional needs of poultry is dependent upon several factors:

- Type of Chicken--Improved breeds do not produce well unless the feed given them contains a proper nutrient balance. Country chickens can withstand a varied diet and can survive under less than ideal feeding conditions. Country chickens may do quite well on locally produced (non-commercial) feed because these birds are low producers. But they too will grow faster and produce better if food intake is improved.
- Size of Operation--If a farmer has only 100 chickens, it will probably be more costly and certainly more time-consuming to mix feed than it will be to purchase from a commercial source. Additionally, the smaller the poultry operation, the less reliable or steady will be the supply of necessary ingredients. If there are 20 or so small farmers, a poultry cooperative which has feed mixing and storage services could well be an answer.

- Climatic Conditions--In hot climates with humid conditions, feed cannot be stored more than a month without spoilage. Vitamins deteriorate rapidly in hot climates and must be used within a few days after purchase unless refrigeration is available. Again, large feed mixing operations can purchase and use vitamins rapidly. All ingredients which contain fat must be used quickly as well. If a commercial anti-oxidant is available and not too costly, buy it and mix with any ingredients which contain fat.
- Availability of Commercial Feeds--In addition to the cost factor mentioned earlier, other factors in favor of commercial feeds must be taken into consideration. The commercial supplier takes care of ingredient purchasing, price negotiation, transport, advance planning, storage of buffer stock and contracting with ingredient suppliers. If a commercial feed is available and you cannot answer where ingredients will come from a year from now for your own mixing operation, you probably should rely on the commercial source. You must be certain you will have the proper mix of ingredients to provide all necessary nutrients at all times.

- Type of Operation--A broiler operation will require a steady supply of feed for only seven to ten weeks. Ingredients may be available for short periods in line with harvest and grain milling, fishing times and other seasonal variations. Layer operations are different. The feed must be available without interruption throughout the year, and year after year, to be successful.

## Commercial Feeds

Except in some remote areas, farmers will probably use commercial feeds for improved breed operations. Commercial feed, in most places, will come in the form of a dry mixture called mash. Whether commercial or home-mixed, feeds must match the different protein needs of chicks, growers (stage between chick and adult), broilers or layers. It is the protein content which distinguishes what feed should be given to these different ages and types of chicken. Commercial feeds are sold with these designations:

- Chick mash--Fed from a chick's hatching until eight weeks old, chick or starter mash contains 20 percent protein.
- Grower mash--Fed from 9 to 20 weeks old, grower mash contains 16 percent protein.
- Broiler mash--From hatching to sale, broilers need large amounts of protein for rapid growth and their feed contains 22 percent protein.
- Layer mash--Through the laying period, hens receive mash containing 16 to 18 percent protein. (This level is usually recommended. However research indicates that a 15 percent level is sufficient to maintain a high level of production as long as the essential amino acid content is balanced. Where protein costs are very high, it may be wise to try the 15 percent level. Otherwise use 16 to 17 percent to allow a good margin of safety.)

If you are using a commercial feed, you may want to have it checked out by a laboratory occasionally to ensure it continues to have the proper content. Your local government may have this capacity.

Some farmers using commercial feed will want to give greens and cereal grains to the chickens.

Greens are sometimes used to reduce cannibalism or to make the egg yolks darker in color. If greens are used, try to encourage use of high protein types such as alfalfa, clover, bean, pea and lentil greens. Discourage use of cereal grains unless the amount fed is included in the feed mixing plans. Remember, a chicken can eat only a certain amount of feed. Every grain of corn, rice, etc., (which contains almost no protein) eaten reduces the intake of protein, vitamins and minerals contained in the balanced ration.

## Feeding Methods

Among the ways of feeding chickens are:

- Whole grain--Feeders often are used for whole grain, either by itself or mixed with other nutrients. Sometimes whole grain is scattered in the litter. The whole grain method of feeding is not recommended. When fed in with other ingredients, the grain is eaten first, resulting in improper diet; when scattered, much is contaminated or lost.
- Wet mash--Chickens usually

eat more wet mash than dry because they enjoy its consistency. However, wet mashes, particularly in hot weather, go bad very quickly. If wet mash is fed to increase feed and water consumption in hot weather, feed only an amount which will be consumed within two hours.

- Dry mash--When it is well-balanced and stored properly, dry mash usually is the best way of feeding contained chickens.
- Pellets or crumbles--Commercial mixtures in pellet or crumble form are excellent but usually too expensive.
- Home-mixed feeds--The decision of whether to mix feed or use a commercial source has already been discussed to some extent.

These factors should be reviewed:

- Economics--Is it really less expensive and/or more profitable to mix feed?
- Logistics--Will there be a reliable and constant supply of ingredients available which will result in having the proper mixture(s) year-round?
- Equipment--Is feed mixing equipment available? If not, can it be made locally?
- Technology--Will provisions be made to ensure that the knowledge required for proper

feed mixing stays in the local area?

- Is the commercial feed up to par with what you can mix yourself? Does the commercial company do a consistent job in preparing the feed?

If it is cheaper and feasible to mix balanced feeds, the process is not too difficult to learn. The problem of a continuous supply of ingredients is the one of most concern. Mixing feed takes time and patience, especially in formulating rations.

If you have decided to try mixing your own feed, you will need to know nutrient requirements of chickens, something about what those nutrients are, sources of nutrients, how to formulate a balanced ration and the mechanics of mixing the various nutritive ingredients properly. Some ingredients contain toxic substances, others too much fiber, and you will need to know about avoiding excessive inclusion of these in your feed mixtures. Finally, once mixed, feed must be properly stored. Much of the information in this feed mixing section will be included in the appendices.

# Nutrient Requirements of Poultry

## Energy

Energy, measured in calories, is required by birds to move, eat, digest, grow, maintain body temperature and, in the case of layers, produce eggs. Chickens get energy from:

- Carbohydrates--Grain, roots, tubers and other starchy foods and sugars provide carbohydrates, the main source of energy in most balanced rations. When the chicken eats starch the large insoluble molecules are broken down into glucose (a sugar). This process, digestion, is brought about by the action of digestive enzymes which are secreted into the intestinal tract. Once formed, glucose is absorbed through the intestinal wall, into the bloodstream and on to the cells of the body. Carbohydrates can be divided into two categories:

Nitrogen-free extract--easily digestible to form glucose, energy-rich material

(starch).

Crude fiber--cellulose and other difficult-to-digest materials: alfalfa, sorghum, bran, oats. Crude fiber content of feed ingredients must be considered in relation to formulation. Too much crude fiber is usually what you must watch for. If the diet contains too much, the chicken will not be able to eat enough feed to meet its needs for energy, protein, etc. A common problem in many countries is using too much rice bran in the feed. Rice bran is a good, inexpensive ingredient, but it often contains a high fiber content. Mixed feed should not contain more than five to seven percent crude fiber where possible.

- Fats--Have more than twice the energy value of carbohydrates. Fats are usually too expensive for use in poultry feeds because of the demand for human consumption. Additionally, fats break down rapidly, causing feed spoilage. The more fat in the feed, the shorter time it can be safely stored. Feed spoiled due to breakdown of fat is called rancid. Feeds containing fats are fish meal and peanut meal.

Not all energy eaten by the chicken is used. The energy that can be used

is called metabolizable energy (ME). Other energy is ejected in the feces.

The specific energy requirements of chickens depend on age, production level (layers) and environmental conditions (degree of confinement, temperature) as well as other factors. For the purposes of feed formulation, energy requirements for the different ages of chickens are:

Metabolizable Energy (ME)

	<u>calories/lb.</u>	<u>calories/kg</u>
0-8 weeks	1,250	2,750
8-20 weeks	1,280	2,815
20 weeks on	1,335	2,950

**Protein**

Protein consists of various combinations of amino acids. Amino acids are essential for tissue building and body functions. Essential amino acids are those which cannot be made by the chickens. High quality protein sources are those which contain larger amounts of the essential amino acids.

Those which are low in essential amino acids are low in protein quality. Animal proteins, such as fish meal and meat meal, are high quality, and vegetable proteins are considered low quality. See Appendix E for protein and amino acid requirements.

Of the 13 amino acids listed in Appendix E, only arginine, lysine, methionine, cystine and tryptophan are of importance in feed formulation, because they are the most limited in many protein sources, and therefore it is difficult to meet the minimum requirements of these essential nutrients. Mixed feed could be deficient in these five amino acids even if the total protein content of the feed is adequate. Of these, requirements for lysine, methionine and cystine are the most important and should be met first because they are the most difficult to meet. It is likely that all other amino acid requirements will be in a feed which has enough of these three. In order to meet the minimum requirements of these amino acids it is most likely that you will need at least one animal protein source.

## Vitamins

Vitamins are organic compounds required in extremely small quantities but essential for normal growth, health and productivity.

- Vitamin A--Requirements are expressed in United States Pharmacopoeia units (U.S.P.), which are the same as International Units (I.U.). Vitamin A is easily destroyed by heat, sunlight and contact with air, minerals or rancid oils. Vitamin A is found in corn, sorghum, soybean, alfalfa and all green leafy vegetables.
- Vitamin D--Requirements are expressed in International Chick Units (I.C.U.), which measure only the quantity of D<sub>3</sub> and not D<sub>2</sub> because chickens can utilize only D<sub>3</sub>. Chickens under daily sunlight can make their own D<sub>3</sub>. Other chickens must have D<sub>3</sub> in their feed. Use of artificial Vitamin D<sub>3</sub> is usually necessary for contained units.
- Vitamin E--Since cereal grains contain a large amount of Vitamin E, deficiency is not likely in most poultry feeds.
- Riboflavin--Feeds with only cereal grains in the mix are probably deficient in ribo-

flavin.

- Pantothenic acid--Rations with enough riboflavin will have enough pantothenic acid.
- Other vitamins--Vitamin K, niacin, thiamin, pyridoxin, biotin, choline are other vitamins required by chickens, but deficiency is not probable in an otherwise balanced feed mix.

## Minerals

Minerals are basic elements required for use in many life support functions. Not all the necessary minerals will be found in an otherwise balanced feed. Thus mineral supplements must be added.

(See Appendix E.)

- Salt--Will have to be added to the feed mix unless fish meal with a very high salt content is included in the mix.
- Calcium and phosphorus--Of particular concern are calcium and phosphorus, which most certainly will have to be provided separately (for laying hens).



## Non-nutrient Feed Substances

- Grit--Grit consists of small stones which are used in the gizzard of the chicken to grind up feed. It is usually provided in a feeder separate from the mash.
- Water--Necessary for all life.
- Medications--To control coccidiosis, medications often are mixed into the feed. Coccidiosis medications are called coccidiostats. Antibiotics sometimes are included at very low levels in feed for growth promotion. When used for medical purposes, high levels for short periods of time as per specific disease control is recommended. Antibiotics are not used for disease prevention because if fed at a constant level over an extended period of time antibiotic-resistant bacteria will result. Antibiotics are not used for growth stimulation after the age of 20 weeks.

## Ingredient Use Limits

Appendix E contains a list of ingredients which should be used only to a limited amount in a feed mix. Some reasons for this limitation are:

- Crude fiber--Content in the feed will be too high if more than the recommended amount of some ingredients is used.
- Toxins--Cottonseed meal contains a toxin and should be used only in limited amounts. So does soybean meal unless it is heat-treated.
- Palatability--Excessive use of some ingredients or its texture (too powdery or gummy) will make the feed unpalatable to the chickens, resulting in lower feed consumption.
- Fishy tasting eggs--Will result if too much fish meal is used.
- Poor nutrient balance--Too much of any ingredient (over 50 percent rice polish, for example) will make it difficult to balance the ration. The listed amounts are given in some cases to simply help you in attaining a balanced ration.

## Sources of Feed Nutrients

The charts in Appendix D list the amount of nutrients contained in 33 sources. Using the nutrient requirements listed in the appendices, and the methods outlined on the following pages, you can calculate a balanced feed.

You can add your own list of ingredients to use as nutrient sources. You may have termites, meat scraps from a local slaughterhouse to cook, dry in the sun and grind up, bananas, papaya, breadfruit, ipil-ipil (*Leucena* sp.), and/or winged beans. Consult with local authorities regarding unconventional ingredients to ensure they are safe and recommended.

### Formulating a Ration

Arriving at a balanced chicken

feed (ration) requires a considerable amount of trial and error, patience and determination. But, with a good formula the farmer will save money and control feed costs, which is the farmer's major expense.

Become familiar with the price, nutritive value, availability and other characteristics of all actual and potential feedstuffs in your area. If they are not listed on the feed formulation charts, a local nutritionist may have information on them. Steps in formulating a feed are:

Step 1--Start by satisfying the protein requirements, both for quantity and quality (amounts of essential amino acids). To come close, use one animal source and one vegetable protein source. Be particularly concerned with meeting the requirements for lysine and methionine (methionine + cystine, in place of methionine alone will do). Meeting requirements for lysine and methionine are generally most

difficult of all, which is why they are the first to be balanced. While calculating protein requirements, also look for high-energy, low-cost carbohydrate sources for energy, such as maize (corn), wheat, cassava flour and rice polishings. Some protein will be found in these sources and this can reduce total feed costs. Once the lysine and methionine requirements have been met, check to ensure all other essential amino acid requirements are met.

Step 2--Next, balance the protein and energy contents.

Poultry eat primarily to meet their energy needs. This means they will eat more of a low-energy ration than a high-energy one. If the ration is too high in energy, the chickens will eat less feed, thus meeting their energy needs, but not their other needs--especially protein. In such a diet, the protein content should be increased. It is

safer to exceed the protein minimum than fall short. In this step also, calculate the total crude fiber content of the feed. Try to keep it below five percent.

Example--If feed for chicks (20 percent protein requirement) has 3,000 cal. per kg (1,373 cal. per lb.), which is more than the 2,750 (1,250) needed, protein content must be increased to 21.9 percent.

	<u>per kg (per lb.)</u>		
calorie requirement	2,750 (1,250)	20%	protein requirement
	_____	=	
calorie content	3,000 (1,373)	21.9%	protein level adjusted for energy content

Keep the ration of calories to protein in line with the various needs of the birds. Try to stay within two percent of the ratio.

Calorie/protein ratio: For purposes of simplicity, the calorie/protein ratio is calculated

by dividing the number of percentage points in the protein requirement of a given age or type of bird. The resulting number or ratio is useful only as a guideline in checking to be sure you have enough protein in the feed. The ratio is meaningless otherwise.

Example: For chick feed you need at least 2,750 calories per kg and 20 percent protein. The calorie/protein ratio is:

$$\frac{2,750}{20} = 137 \text{ cal/protein ratio}$$

In the prior example we had 3,000 calories and a 20% protein requirement. To test the balance between protein and energy, the calorie/protein ratio is:

$$\frac{3,000}{20} = 150 \text{ cal/protein ratio}$$

Since the proper ratio is 137, the protein content must be adjusted up to 21.9 percent, resulting in:

$$\frac{3,000}{21.9} = 137,$$

the correct ratio.

Step 3--If the calcium and phosphorus in your formula is low, add limestone, dicalcium phosphate or bone meal to meet requirements. For the birds to use both effectively, have about twice as much calcium as phosphorus in the feed. You only need about 60 percent of the calcium requirement in the feed itself if the flock has access to a calcium-source hopper.

Step 4--Most foods, especially fish or meat meal, contain some salt. Therefore, add about 0.25 percent salt to the ration, that is 250 g per 100 kg (4 oz. per 100 lbs.).

Step 5--Balancing the vitamin and mineral contents of various foods requires many calculations. An easier and accepted way to meet these needs is with a commercial vitamin-mineral supplement. If you follow the supplement's directions, the birds get enough of their needs without any harmful excesses.

## Example of Feed Formulation for Chicks

Assume the following is available:

# Source	Cost		Percentage of protein	Protein cost	
	100 kg	100 lbs.		per kg	per lb.
<u>Carbohydrate:</u>					
22. Rice polish	\$ 4.95	\$ 2.25	11	--	--
24. Sorghum	8.25	3.75	9	--	--
5. Maize (corn)	9.90	4.50	8.5	--	--
<u>Protein:</u>					
7. Cottonseed meal	7.70	3.50	44	18¢	8¢
27. Soybean meal	17.60	8.00	50	35	16
13. Fish meal	24.20	11.00	60	40	18

Balance the ration's protein quantity and quality. Chicks need at least 20 percent protein, 1.1 percent lysine, and 0.75 methionine (or methionine + cystine) in a ration containing 2,750 calories of ME per kg (1,250 calories per lb.). Cottonseed meal is the cheapest protein source, but it can't be used for more than 15 percent of the feed (see page 198). Soybean meal is the next cheapest, and will help balance the relatively low lysine content of

the cottonseed meal. All three carbohydrate sources supply about equal amounts of energy, and their protein contents are about the same.

Therefore, in this example use rice polish at near its maximum permissible rate (50 percent) because it is the cheapest. Although maize supplies much Vitamin A, it still is too expensive. Instead, use sorghum as the second carbohydrate source.

## ample Test Formulation

	Kg	<u>Protein</u>		<u>Lysine</u>		<u>Methionine</u>		<u>Cystine</u>		<u>ME*</u> <u>Calories</u>
		%	kg	%	kg	%	kg	%	kg	
ce										
polish	45	11	4.9	0.5	0.22	0.2	0.09	0.11	0.049	148,500
orghum	20	9	1.8	0.2	0.04	0.16	0.03	0.15	0.03	66,000
ttonseed										
meal	15	45	6.6	1.8	0.27	0.66	0.10	0.90	0.135	30,030
ybean										
meal	<u>20</u>	<u>50</u>	<u>10.0</u>	<u>3.2</u>	<u>0.64</u>	<u>0.7</u>	<u>0.14</u>	<u>0.74</u>	<u>0.15</u>	<u>50,600</u>
tal										
kg	100	23.2		1.17		0.36		0.364		295,130

\* Total kg x calories per kg To find ME per lb., divide by 2.2.

This test ration has about 2951 calories per kg, more than needed, so more protein should be added.

calorie requirement	<u>2,750</u>	20%	protein requirement
calorie requirement	2,951	21.5%	adjusted protein level needed in this ration

The test ration actually has:

	<u>Test ration content</u>	<u>Requirement</u>
Protein	23.30%	21.5% (adjusted)
Lysine	1.17	1.2
Methionine + Cystine	0.17	0.8

The test ration is too high in protein quantity, but deficient in lysine and methionine + cystine. Some soybean meal might be substituted for some cottonseed meal, since the former has a higher lysine content. However, the ration still would be short on methionine. The total proportion of soybean meal might be increased, leaving the cottonseed meal as it is, but then the protein level would be uneconomically high.

However, fish meal, which wasn't included in the first test ration because of its cost, is a good source of lysine and methionine. If some is substituted for soybean meal, protein quality needs will be met. Since the protein quantity in the first test ration already is too high, the proportion of sorghum should be increased (rice polish already is being used at the maximum level allowed).

### Example Second Test Formulation

	<u>Kg</u>	<u>Protein</u>		<u>Lysine</u>		<u>Methionine</u>		<u>Cystine</u>		<u>ME</u> <u>Calories</u>
		<u>%</u>	<u>kg</u>	<u>%</u>	<u>kg</u>	<u>%</u>	<u>kg</u>	<u>%</u>	<u>kg</u>	
Rice polish	45	11	4.9	0.5	0.22	0.2	0.09	0.11	0.049	148,500
Sorghum	25	9	2.2	0.2	0.05	0.16	0.04	0.15	0.037	82,500
Cottonseed meal	15	44	6.6	1.8	0.27	0.66	0.10	0.9	0.135	30,030
Soybean meal	5	50	2.5	3.2	0.16	0.7	0.035	0.74	0.037	12,320
Fish meal	<u>10</u>	<u>60</u>	<u>6</u>	<u>5.2</u>	<u>0.52</u>	<u>2</u>	<u>0.2</u>	<u>0.95</u>	<u>0.095</u>	<u>26,400</u>
Total kg	100	22.2		1.22		0.465		0.353		299,750

The second test ration, with 1.22 percent lysine and 0.82 percent methionine + cystine, meets protein quality requirements. The ration's ME is 2,997 calories per kg. To adjust protein level to that energy level:

calorie requirement	2,750	20%	protein requirement
	<u>        </u>		
calorie requirement	2,997	21.8%	adjusted protein level needed in this ration

The protein content of the second test ration, 22.2 percent, is a little higher than the adjusted need, but that is a good safety margin.

Finally, checking on arginine and tryptophan (Appendix E, page 204), we find that these amino acid requirements have been fulfilled. (The ration has 1.49 percent arginine, more than the 1.2 percent required and 0.25 percent tryptophan, more than the 0.20 percent required.)

Now that the ration is balanced for energy, you can calculate cal-

cium, phosphorus and salt needs. Looking at the tables (Appendix E, page 205), you will find the ration has 0.79 percent calcium. The minimum is one percent, so add about 0.35 percent to be on the safe side. The ration's available phosphorus content is about 0.28 percent. Therefore, add 0.4 percent to keep the calcium/phosphorus ratio in the recommended range (1.8 - 2.2 to 1). About 0.3 to 0.4 percent salt will be needed in this ration. Vitamin and other mineral needs will be provided by the commercial supplement. You can also calculate the vitamin and mineral content of your feed mix. But this is difficult. It is easier, and usually less expensive, to use a commercial vitamin/mineral supplement available in almost all countries. Finally, if you are adding a coccidiostat or other substance, follow the instructions on their packages.



## Using a Protein Concentrate

When commercial feeds are too expensive and mixing a complete ration is impractical, you can mix a commercial protein concentrate which also contains vitamins with local grains or other carbohydrate sources, and perhaps some calcium. The concentrate's formulation, if available, will help you to balance the feed. When using a concentrate it is necessary to know all the ingredients in it and their specific nutrient makeups. Remember, vitamins deteriorate rapidly. If the concentrate is old, it has been kept or transported improperly, the vitamins may have become useless.

Use the square method to determine the relative proportions of protein concentrate and carbohydrate needed for particular types of rickens.

Example--Concentrate with 44 percent protein, mixed with maize (8.5 percent protein), to obtain a 16 percent protein ration. In these calculations, the parts are by weight:

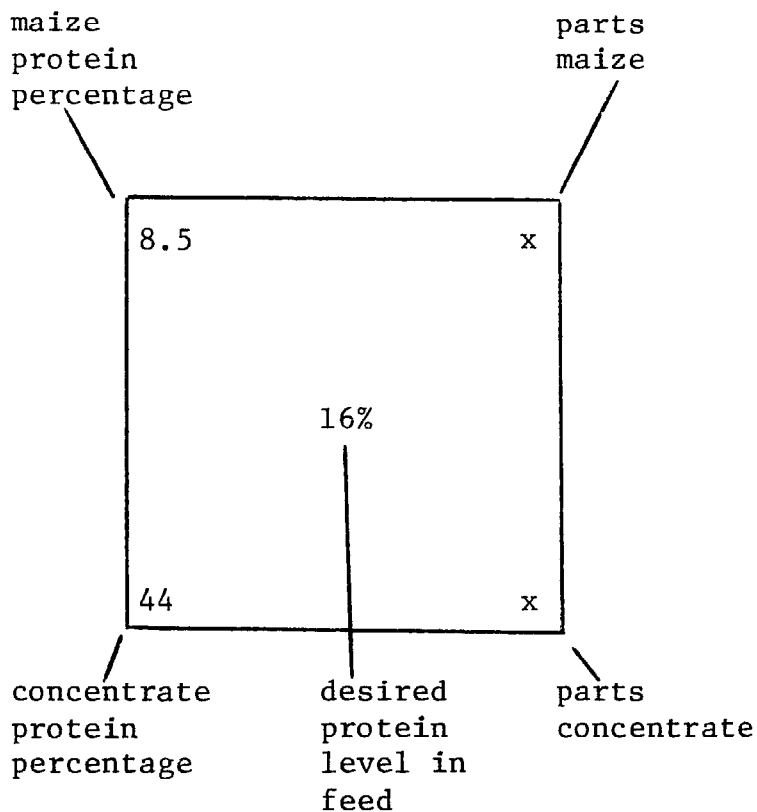

To find the right combinations, work diagonally, subtracting the smaller numbers from the larger:

$$16 - 8.5 = 7.5 \text{ parts concentrate}$$

$$44 - 16 = \underline{28} \text{ parts maize}$$

$$35.5$$

To find the percentage of each in the feed, divide each number of parts by the total parts:

$$\frac{7.5}{35.5} = 21.1\% \text{ concentrate}$$

$$\frac{28}{35.5} = 78.9\% \text{ maize}$$

## Mixing Feeds

Feed must be mixed thoroughly so that all chickens receive a balanced ration. Coccidiostats, vitamin and mineral supplements and other additives are used in such small amounts that they must be incorporated gradually. First, put in 1 - 2 kg of an ingredient and mix very well. Then add this mixture to approximately 5 kg of feed, mix well again, then add to the

remaining feed before mixing it. Don't pre-mix the vitamin and mineral additive with the calcium, phosphorus and salt -- add them separately to the total feed. There are several ways of mixing feed.

- By hand--You can mix 10-20 kg (22-44 lbs.) of feed at a time in a large tub. Or, you can layer ingredients on a cement floor or sheet of plywood or metal. Shovel the feed out from the center and then back, repeating the process until

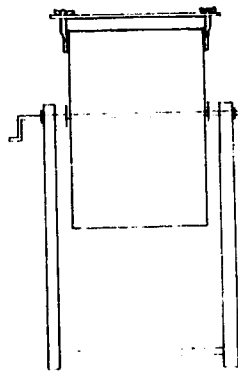
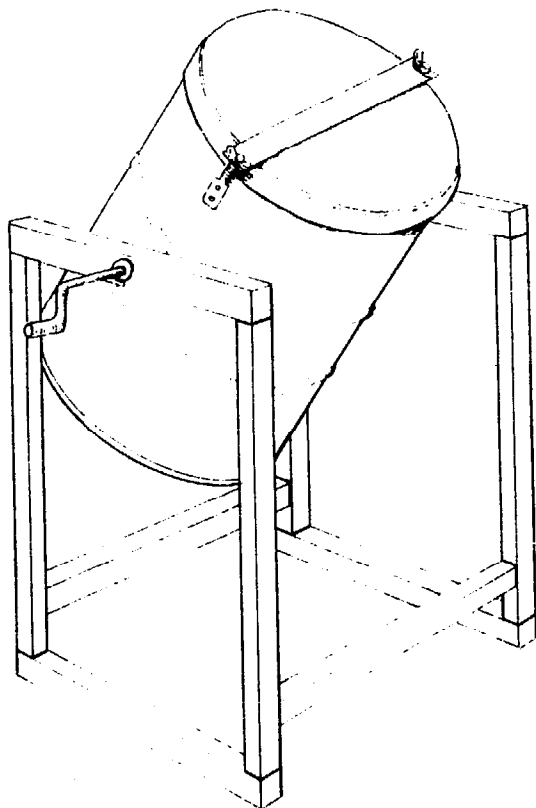

Tumble Mixer

the feed is completely mixed. Repeat several times and remember when shovelling to the center always to allow the shovelful of feed to fall on the tip of the cone that is being created, which allows more even spread of the nutrients.

- Tumble mixer--A clean oil drum, mounted eccentrically on a stand, makes an excellent manual mixer. If fitted with ball bearings, it can handle up to 70 kg (150 lbs.).
- Powered mixer--If enough local farmers are mixing feed manually, they may want to join to build or buy a powered mixer. Agricultural extension agents should have suggestions on designs or sources.

## Grinding Feed

Grain for chicken feed should be ground to a medium coarseness to be mixed with the other ingredients.

If it is too coarse, the birds will pick it out and leave the rest. If it is too fine, it will sift through the rest to the bottom of the feeder.

Very finely ground grain can become impacted in a bird's beak, and birds will be reluctant to eat it.

## Storing Feed

Mixed feed should be stored in a pest- and rodent-proof container raised off the floor. In hot weather, try not to mix and store more than a week's supply at a time. Be especially careful when the feed has a high fat content--if it goes rancid, the flock will probably get sick or will experience nutritional deficiencies. When buying a premix, buy one with an antioxidant to help stop rancidity. Clean the container before putting in a new supply of feed.

Bags of feed or ingredients need a pest-tight room, where they should be stacked on slatted platforms raised at least 30 cm (1 ft.) above the floor, so cats or dogs can patrol underneath. For other ideas on storing feed, obtain the Peace Corps' Small Farm Grain Storage Manual from the local Peace Corps office or from ICE (see inside front cover).

# Nutritional Deficiencies

The definite diagnosis of nutritional deficiencies in chickens requires experienced technicians and sophisticated pathology laboratory facilities. This is because:

- Deficiency symptoms are not noticed until severe.
- Symptoms of any specific nutrient deficiency are similar to symptoms of non-nutritional diseases and/or other deficiencies.
- Deficiency symptoms are not easily diagnosed, even in a laboratory. The fastest way to diagnose deficiency of amino acids is to calculate the amino acid content of the feed mix and if possible have the feed analyzed by a laboratory for confirmation.

## Vitamin Deficiencies

Vitamin deficiencies in properly balanced rations are caused by loss of vitamin potency due to age or storage conditions. Vitamin deficiency symptoms include:

- Vitamin A--Decreased growth in chicks, reduced egg production in layers, along with reduced quality of eggs produced and paling of egg yolks. (Symptoms could be a result of many other causes.) Odorless substances in eyes and nasal passages. Staggering walk and nodules in the esophagus.
- Vitamin E--Deficiency causes poor growth, uncoordination, stumbling, general muscular uncoordination in chicks, usually beginning no earlier than 3-4 weeks of age. It is frequently most severe when accompanied by coccidiosis disease. Also causes death of chick embryo after 3-4 days' incubation.
- Riboflavin--Vitamin B<sub>2</sub> deficiency causes poor growth, low hatchability, curled toes (although some chicks have curled toes at hatching, which is probably a genetic problem and not a deficiency symptom). If many chicks develop curled toes after hatching, it could be a riboflavin deficiency.
- Vitamin D--Deficiency causes weak legs, soft or brittle bones, poor growth, weak egg shells, enlarged joints, low hatchability.

There are many more vitamins and minerals which can cause poor

growth, paralysis, low hatchability, increased mortality and so on. The real answer is to know what is in the feed being given to the chickens and avoid, as much as possible, the possibility of deficiencies.

In the case of country chickens and in locations where artificial vitamin supplements are not available, inclusion of the following foods in the diet will substantially reduce the chance of vitamin deficiencies:

Vitamin A--Edible oils, grasses, yellow maize, alfalfa, clover, most green leafy material.

Thiamin--(Vitamin B<sub>1</sub>) Whole grain and grain by-products, peanut meal, soybeans, grasses, and alfalfa.

Riboflavin--Residues from fermentation processes such as brewery residues, alfalfa, grasses, some fish meals.

Pantothenic acid--Peanut meal, cereal grain brans, alfalfa, grasses, fermentation residues.

Pyrodoxine--(B<sub>6</sub>) Rice bran, fish, wheat and rice by-products, alfalfa.

Niacin--Rice bran, wheat, peanuts, meat, greens and fermentation residues from corn distillers.

Choline--Whole grains, cereal

brans and polishings, peanut meal, soybean meal.

Biotin--Root tubers, alfalfa, grasses, whole grains.

Cholic acid--Grasses, kale, alfalfa, wheat by-products, soybean meal.

Ascorbic acid--Vitamin C deficiency has never been found in domestic chickens.

Vitamin D<sub>3</sub>--Sunshine, fish oils and concentrates, sun-cured grasses.

Vitamin E--Found in all cereals and cereal brans, polishings, green foliage, alfalfa meal.

Vitamin K--Alfalfa, most green leafy vegetable matter, plant oils, meat scraps, fish meal.

B<sub>12</sub>--Bean and peanut oil meals, dried cow manure, various fermentation products.

## Other Deficiencies

Salt--Simply put enough salt in the ration. For country chickens just add a pinch of salt to their feed mixture.

Anti-Gizzard Erosion Factor--Kale, grasses, alfalfa, wheat products, soybean meal.

Minerals--Other than calcium and phosphorus, deficiencies are not likely if a variety

of ingredients is used in feed. In isolated cases, if there is a mineral deficiency in the soil on which plants and animal ingredients are produced, there also will be a deficiency in the mixed feed.

A final word on nutrition for those who don't have access to commercial feeds or traditional ingredients. You must keep your eyes open for ideas on alternative feed ingredients. All types of insects and weeds are potential feed ingredients. Since little research has been done on these, you must use caution during early stages of feeding these. If you find that some local research has been done, use the results. Use common sense. Some seaweeds are high in protein and minerals, but must be washed with fresh water, dried and fed only to a limited extent due to high salt content.

### **Points to Consider Before Using Non-Traditional Ingredients**

- Don't consider using an ingredient that also serves

as human food.

- If energy feed stuffs (or protein feed stuffs) are not available, it will probably be easier and cheaper to import a complete feed.
- It may be even cheaper to import eggs or chicken meat.
- Processing methods used will determine the energy and protein and vitamin content of various feed ingredients. For example, note the differences in the percent of protein content of soybean meal in the Feed Formulation Chart, Appendix D (page 197).
- Remember that many plant origin foods are likely to contain toxins--thus restrict use of these substances in large quantities.

# 9. Poultry Marketing and Finances

Before farmers enter the poultry field or expand current flocks, they must carefully consider what they will do with the meat and eggs their families don't eat. Forming a market plan means identifying where and when birds and eggs will be sold to receive the best prices. Suddenly putting large numbers of broilers up for sale in a small community may depress the price. Even small numbers of layers need advance planning--a flock of 100 may produce 1,000 dozen eggs in a year, even at the low production rate of 50 percent.

The plans of other farmers also must be considered. If all expand their operations and have good years, prices almost inevitably will fall. Seasonal considerations enter into market plans as well; in

India, for instance, eggs are thought of as heating foods and are eaten in cool, rainy seasons.

Any farmer who wants to market poultry products must be sure that they are fresh and of high quality so that consumers continue to buy them. A reputation for good products is the farmer's greatest asset.

Many small farmers are reluctant or unable to keep records, yet good records are a key to success. Without them, it is extremely difficult to spot problems and correct them. Wasteful practices can go unnoticed, and the farmer may even operate at a loss and not know it.

# Marketing Country Chickens

meat birds, although there will be some eggs for consumption or sale. The worksheet below assumes that the flock began with ten chicks hatched and brooded by a hen.

If you are working with country chickens, consider them primarily as

---

## Country Chickens--Expenses and Income

---

### Expenses

Night shelter, if any .....	_____
Feed supplement, if any .....	_____
Nest, if any .....	_____
Worming medication, if any .....	_____
Other (vaccinations, etc.) .....	_____
Total expenses .....	_____

### Income

About 60 eggs per year x 3-4 hens	
x price per egg (210 x _____)	_____
Sale of 4-5 males at 15 weeks	
x average price (4.5 x _____)	_____
Sale of 3-4 hens at 1-1/2 years	
x average price (3.5 x _____)	_____
Total income .....	_____
Less expenses, if any .....	_____
Profit, (or loss) .....	=====

---



# Marketing Medium-Size Broilers

The older meat birds are, the less weight they gain per unit of feed consumed. It is important to sell them as soon after eight weeks of age as possible if they are of weight. The chart below lists aver-

age weights and feed consumption for a male meat bird (actual feed consumption and weight gain may vary widely, depending on quality of breed, feed and care). Many farmers, especially with medium-size flocks, may find it helpful to weigh feed before giving it to the flock and to weigh a sample of birds at least once a week (see page 158).

## Feed Consumption--Male Broiler

<u>Age in Weeks</u>	<u>Weight of Bird</u>		<u>Feed Consumption Per Week</u>		<u>Added Weight Per Unit of Feed per Week</u>	<u>Weight of Feed To Produce 1 Unit of Weight Gain*</u>
	<u>kg</u>	<u>lbs.</u>	<u>kg</u>	<u>lbs.</u>		
1	0.09	0.21	0.11	0.25		1.19
2	0.20	0.44	0.15	0.33	0.69	1.43
3	0.39	0.86	0.29	0.64	0.66	1.52
4	0.59	1.30	0.37	0.82	0.54	1.86
5	0.82	1.81	0.48	1.06	0.48	2.08
6	1.07	2.36	0.54	1.19	0.46	2.16
7	1.33	2.94	0.61	1.35	0.43	2.33
8	1.60	3.53	0.67	1.48	0.40	2.51
9	1.88	4.13	0.72	1.59	0.37	2.65
10	2.16	4.75	0.81	1.78	0.34	2.87

\*Multiply this value by the price of feed per unit of weight. If the result is near the estimated price per unit of weight the birds can be sold for, continuing to feed them will be unprofitable. Figures in this chart are not adjusted for mortality.

Feed Consumption--Male Broiler (Cont.)

<u>Age in Weeks</u>	<u>Weight of Bird</u>		<u>Feed Consumption Per Week</u>		<u>Added Weight Per Unit of Feed per Week</u>	<u>Weight of Feed To Produce 1 Unit of Weight Gain</u>
	<u>kg</u>	<u>lbs.</u>	<u>kg</u>	<u>lbs.</u>		
11	2.42	5.32	0.90	1.98	0.29	3.47
12	2.70	5.94	1.00	2.21	0.28	3.56
13	2.95	6.50	1.09	2.39	0.23	4.27
14	3.21	7.06	1.27	2.80	0.20	5.00

Rare is the small farmer in the developing world who has access to refrigeration. Since meat spoils within a few hours unless kept cold, most broilers are sold live, either directly to consumers or through an established marketing system. Chickens can be transported to the market in well-ventilated baskets or wooden crates. Don't feed them on the day of sale, but be sure they receive plenty of water. If the trip to the market takes eight hours or more, stop and supply water to the birds or they may die. In hot weather, it is good to transport birds at night or in the early morning.

Most countries have set standards or commercial grades for meat birds, based on size, amount of meat per bird, skin color and condition and other factors. A small-scale farmer usually need not be concerned with grading, but should protect the farm's reputation by sending only good quality birds to market and either eating others or selling them locally.

In the worksheet below, it is assumed that good management has kept mortality and feed consumption down, while producing healthy, heavy birds. Actual feed consumption and weight at sale may vary considerably.

100 Male and Female Broilers, Sold at 9 or 12 weeks--Expenses and Income

Expenses

Feed: sold at 9 weeks 398 kg (875 lbs.) x _____ (feed price)	_____
sold at 12 weeks 636 kg (1,400 lbs.) x _____ (feed price)	_____
Housing* .....	_____
Waterers, feeders, and other equipment*...	_____
Heating and lighting .....	_____
Brooder and equipment* .....	_____
110-day-old chicks, plus transport .....	_____
Interest on financing, if any .....	_____
Contingency for emergencies (medicine, extra feed, etc.), add 10% .....	_____
Vaccinations .....	_____
Containers and transport to market .....	_____
Total expenses .....	_____

Income

100 broilers: sold at 9 weeks 190 kg (375 lbs.) x _____ (est. price)	_____
sold at 12 weeks 241 kg (530 lbs.) x _____ (est. price)	_____
Value of manure sold or used .....	_____
Total income .....	_____
Less total expenses .....	_____
Profit, (or loss) .....	=====

\*If you think housing and equipment will last three years, use 10 percent of these expenses for each 14-week cycle (preparation, growth and sale). If they will last four years, 6 percent, etc.

## Weighing Chickens

Keeping records of the weight of a flock and the weight of feed it eats helps the farmer in several ways. With this information, losses in body weight or decreases in feed consumption, two major signs of disease, can be spotted. In addition, the farmer can more easily see when meat birds have reached uneconomical rates of feed consumption.

The easiest way to weigh a live chicken is to place it head-first in a sheet metal cone. Adjust the scale for the weight of the cone, or subtract its weight from the scale reading.

It is not necessary to weigh all the chickens. A sample of five or ten percent of what appear to be average-size birds will do.

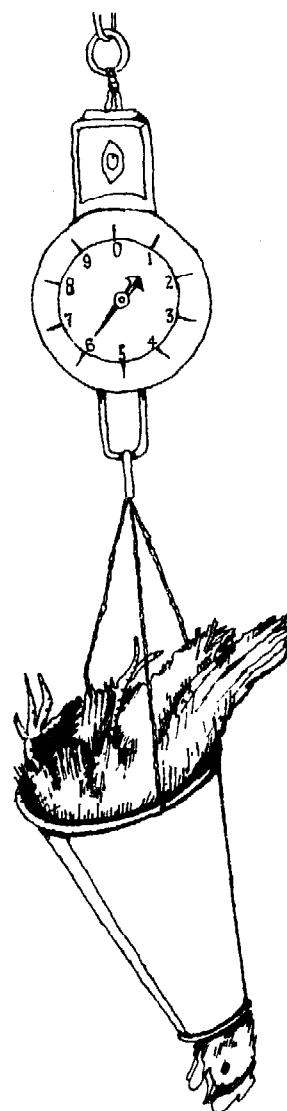

Weighing a Chicken Using a Sheet Metal Cone

## Storing Eggs for Market

Prior to marketing, eggs must be kept as cool as possible, ideally at 4.4 to 12.8° C (40 to 50° F). In hot weather, this often isn't possible, and the farmer should send the eggs to market at least every third day. Don't leave eggs in direct sunshine, even for a few minutes.

One way to store eggs temporarily is to bury a clay pot to its neck in a shaded area. Water the ground around the pot, but don't leave puddles. Put straw or a mat in the pot to cushion the eggs and keep them above any water in the bottom of the pot. Put the eggs in the pot as soon as they are collected, and cover it with a cloth and damp straw. The inside of the pot probably will be about 5.5° C (10° F) cooler than outside.

Eggs absorb strong odors quickly; don't store them near onions, kerosene, etc., or in mildewed areas.

## Cleaning Eggs

Eggs soiled by droppings or the contents of leaking or broken eggs not only spoil faster than clean ones, they fetch lower prices. An egg has a natural protective coating that resists the entrance of bacteria and retains moisture inside. Washing eggs with water removes this protection, so save washing eggs as a last resort and eat washed eggs as soon as possible. A preferred method of cleaning eggs is rubbing them lightly with fine sandpaper, emery cloth or steel wool.

## Egg Grading

The main idea in grading eggs is to sort them so that only good quality eggs are sent to market, and that they receive the best possible prices. The simplest and most

important method of sorting is to divide the eggs into three categories --cracked, dirty and clean. The cracked eggs are eaten by the family or sold locally for immediate consumption. The dirty ones are cleaned and sold locally for consumption within three days, while the clean eggs are sent quickly to the major marketing outlet.

If people pay a premium for eggs of certain colors or sizes, the farmer should sort for those qualities. Most countries have established egg size standards. If none exist in your area, people may want to set their own.

#### Suggested Egg Size Categories

	<u>Grams</u>	<u>Ounces</u>
Jumbo	64 - up	2-3/4 - up
Extra Large	57 - 63	2-1/4 - 2-1/2
Large	50 - 56	2 - 2-1/4
Medium	43 - 49	1-1/2 - 1-3/4
Small	35 - 42	1-1/2 or less

People in a few areas prefer fertile eggs. If you are in such an area, you should allow for this by keeping roosters with the layers. But, for the most part, all eggs sold should

not be fertilized. These will stay edible much longer in warm weather than will fertile ones.

## Storing Eggs for Home Consumption

A clean, unwashed and uncracked egg, kept in shade, should remain edible for up to two weeks. There are three ways of storing them longer without refrigeration. Store only good eggs--use a candler, if possible, to determine their quality.

Oil--A thin film of oil on an egg fills its pores, and reduces evaporation and oxidation of the contents. With a wire basket, dip the eggs into slightly heated oil, about 11° C (20° F) warmer than the eggs. A light mineral oil is best, but almost any cooking oil (such as coconut) that doesn't turn rancid rapidly will do. If you re-use the oil, filter it and heat it to 116° C (240° F) to sterilize it. Oiled eggs will last for at least three weeks--longer if kept under 10° C (55° F).

Clay pot--Place eggs in clay pot buried in the ground. Cover the

pot tightly and be sure no water gets into the pot.

Water glass--For 100 eggs, use a 25-liter (6.5-gal.) pot or jar. Mix 5.25 liters (5 quarts) of previously boiled, cool water with 0.5 liter (1/2 quart) of water glass (sodium silicate). Place the eggs in the pot and cover them with the water glass solution. Cover the pot and keep it in a cool, shaded place. The eggs should keep for anywhere from 1 to 6 months.

Lime water--Mix 2.3 kg (5 lbs.) of quick lime (finely powdered lime) in 6 liters (6.3 quarts) of boiled and cooled water and allow to stand overnight so that the lime settles. Place eggs and the clear lime solution in pot, cover and keep cool. The eggs should last more than a month.

Packaging eggs--With a medium-size laying flock, it may be worthwhile to investigate purchasing special cardboard egg containers--100 layers may produce 2,000 eggs or more a month. Place the eggs small end down in the containers to reduce breakage.

## Size of Flock

To take advantage of economies of scale, this manual recommends that a laying flock contain at least 50 to 100 birds. Many costs, such as housing and equipment, will be about the same as for smaller flocks, as will be the time needed to care for them. The following worksheet assumes good stock, feed and care.

---

100 Layers--Expenses and Income

---

Expenses

Feed, to 24 weeks

White-egg breeds  
1,136 kg (2,500 lbs.) x  $\frac{\quad}{\text{(feed price)}}$  .. \_\_\_\_\_

Brown-egg breeds  
1,418 kg (3,120 lbs.) x  $\frac{\quad}{\text{(feed price)}}$  .. \_\_\_\_\_

Housing<sup>1</sup> .. \_\_\_\_\_

Feeders, waterers, other equipment<sup>1</sup> .. \_\_\_\_\_

Litter .. \_\_\_\_\_

Heating and lighting, if any .. \_\_\_\_\_

Brooder equipment .. \_\_\_\_\_

Brooder fuel .. \_\_\_\_\_

115 day-old chicks<sup>2</sup> .. \_\_\_\_\_

Transport of chicks .. \_\_\_\_\_

Interest on financing .. \_\_\_\_\_

Contingency for emergencies (medicine,  
etc.), add 10% .. \_\_\_\_\_

Vaccine .. \_\_\_\_\_

Total initial investment .. \_\_\_\_\_

Production Cycle--100 Layers

(adjusted for 1% per month mortality)

Feed, for 1 year

White-egg breeds  
4,150 kg (9,125 lbs.) x  $\frac{\quad}{\text{(feed price)}}$  .. \_\_\_\_\_

Brown-egg breeds  
5,000 kg (11,000 lbs.) x  $\frac{\quad}{\text{(feed price)}}$  .. \_\_\_\_\_

Housing .. \_\_\_\_\_

Feeders, waterers, other equipment<sup>1</sup> .. \_\_\_\_\_



Roosts, if used<sup>1</sup> ..... \_\_\_\_\_

Additional litter ..... \_\_\_\_\_

Cages, if used<sup>1</sup> ..... \_\_\_\_\_

Nesting boxes<sup>1</sup> ..... \_\_\_\_\_

Heating and lighting, if any ..... \_\_\_\_\_

Collection and storage (baskets, pots,  
etc.)<sup>1</sup> ..... \_\_\_\_\_

Egg containers, if used ..... \_\_\_\_\_

Transport of eggs and hens to market ..... \_\_\_\_\_

Hired labor, if any ..... \_\_\_\_\_

Interest on financing ..... \_\_\_\_\_

Miscellaneous (worming medication, etc.),  
add 1% ..... \_\_\_\_\_

Vaccinations ..... \_\_\_\_\_

Total production expenses ..... \_\_\_\_\_

Income

Sale of eggs

White-egg breeds -- 24,000 eggs x \_\_\_\_\_  
(price)

Brown-egg breeds -- 23,000 eggs x \_\_\_\_\_  
(price)

Sale or use of manure as fertilizer ..... \_\_\_\_\_

Total income ..... \_\_\_\_\_

Less initial and production expenses ..... \_\_\_\_\_

Profit, (or loss) ..... =====

---

1. Prorate expenses over expected life of housing equipment.

2. If sexed chicks aren't available, buy about 225 chicks, adjust expenses on equipment and feed, adjust income for sale of 100 broilers.

---

## Records

Records should be kept to help in analyzing the operation and pinpoint problems. To be useful, records should be uncomplicated and accurately kept. A farmer should keep track of all expenses (looking

for ways to cut them) and production (seeking methods to increase it). A good way to record egg production is to post a form similar to the one on the next page inside the chicken house with a pencil on a string nearby. A full year's production can be recorded on such a form.

### Egg Production Record

Farmer	Hatch Date										Date Housed					Breed Source					
Date	1	2	3	4	5	6	7	8	9	10	11	12	13	14	15	16	17	18	19	20	
No. Eggs																					
A.M.																					
A.M.																					
P.M.																					
P.M.																					
TOTAL																					
Birds																					
Removed																					
Pounds Mash																					
Other Feeds																					
Date	21	22	23	24	25	26	27	28	29	30	31	Totals for Month					No. of birds				
A.M.																	First of Month				
A.M.																	Sold				
P.M.																	TOTAL				
P.M.																	End of Month				
TOTAL																					
Birds																					
Removed																					
Pounds Mash																					
Other Feeds																					

Month of \_\_\_\_\_ 19 \_\_\_\_\_

If you are working in poultry extension, you will want more information on expenses and production, including:

- Breed, source, hatching date and cost.
- Number of birds at the start and current number.
- Type of feed, daily or weekly consumption and cost.
- Cost of housing and equipment.
- Feed supplement used, if any, and cost.
- Type of medicine or vaccine administered and cost.
- Disease or parasite problems present.
- Type of litter used, if any, and cost.
- Average weekly egg production.
- Weather (hot, cold, sudden change).
- Number of birds culled and reasons.
- Receipts from sale of eggs and meat.
- Family consumption of eggs and meat.

## Increasing Poultry Profits

Cutting costs, increasing production, responding to market conditions, and price fluctuations all can increase profits. Concentrate on:

Feed wastage--Well-designed, durable feeders are worth the expense, for they reduce wastage. Fill them one-third full for minimum wastage.

Space utilization--Try for a full but not crowded house, to keep per-bird house expense as low as possible. An experienced farmer can raise a mixed-sex flock to ten weeks, filling the house, sell the males as broilers, and let the females grow to laying size, filling the house again.

Maintaining production--A 2-kg (4.4-lb.) hen eats about 27 kg (60 lbs.) of feed a year just to maintain her weight. She uses about another 6.8 kg (15 lbs.) to produce her first 100 eggs, about 5.9 kg (13 lbs.) for the second 100, and 6.4 kg (14 lbs.) for the third 100. Good management and culling of non-layers are essential for profits.

Feed quality--An inexpensive feed that is not well-balanced does not save money--it reduces production.

Breed source--Breeds that produce best usually cost more, but make up for it through increasing sales.

Broken or soiled eggs--Good management and frequent collection will minimize losses from broken or soiled eggs.

Deep litter--Chickens lay up to five percent more eggs when kept on deep litter, in addition to producing more valuable fertilizer.

Timing--Try to bring eggs and meat to market when prices will be highest.

mers have a very good record of repaying loans. Drawing up a specific management and repayment schedule may help to overcome lender reluctance. Lenders also may avoid making loans to small farmers for fear that they will misuse the money. One way around this is to have purchases for the flock made through the lender. Some funding sources are:

Government agencies--Most developing countries have agricultural loan programs channeled through administrative or agricultural extension networks.

Private lenders--Banks, traditional local money lenders, and marketing middlemen are possible private lenders. Of course, some may be better than others, and all possible sources should be investigated thoroughly.

International agencies--The World Bank, Oxfam, U.S./A.I.D., CARE, UNICEF and others sponsor rural development in some countries. Often such programs are administered by the host government. Information on these groups and others may be available through your local Peace Corps office or through the Peace Corps Resources Manual.

Others--Cooperatives, credit unions, women's groups, chick suppliers, feed manufacturers

## Sources of Finance

Many small farmers don't have the cash needed to start raising medium-size poultry flocks, and loans are hard to get because poultry raising is often viewed as a high-risk business. It is true that with inexperienced farmers, failures may exceed successes, but studies have shown that small far-

and others may be good credit sources.

A good loan application would include, but of course isn't limited to, the following information:

- A description of the current operation and past successes.
- A current balance sheet.
- A projected income and expense statement.
- A chronological management plan.
- A schedule of visits by extension personnel.
- A market plan, including names of potential buyers with allowances for losses during transport.
- A repayment plan: 10 to 12 weeks later for meat breeds, beginning in seven months for layers.

## Poultry and Egg Cooperatives

Joining or helping to create a cooperative can reduce a farmer's costs and increase income, if the co-op is well run. The formation of a co-op usually is regulated by the

government, which also monitors its operation.

Co-ops can cut costs through bulk purchases of feed, chicks and equipment. They also may buy mixers and prepare their own feed, breed and rear chicks to distribute to members and provide extension advice. In addition, they may provide low-cost financing.

On the marketing side, they can cut transport costs by pooling shipments, inspect and grade products, negotiate large-scale contracts and purchase refrigeration equipment to store products during low-price seasons.

Farmers also may profit by helping to finance the co-op, by working for it and by sharing experience with other members.

# 10. Poultry Extension

Good agricultural extension is a two-way system. From scientists and administrators come research results and suggestions to the farmer; from the farmer come questions and reports of actual results. The agricultural extension agent is the person in the middle, channeling the flow of information in both directions. In addition, the extension agent acts as a relay between different farmers and learns of good ideas from one farmer and transfers this information to others.

## Training and Visit System

In May, 1977 the World Bank published Agricultural Extension: The Training and Visit System by Daniel Benor and James Q. Harrison. The booklet describes a system of orga-

nizing extension personnel that has helped several countries considerably and is spreading to others. Some of their ideas can be adapted to any local extension situation.

The key to the system is the village extension worker (VEW), who has a set schedule of visiting certain contact farmers in the area, has no duties other than extension and receives regular in-service training. The VEW concentrates on supplying the latest, most easily adapted agricultural research recommendations in small, well-timed units, or digestible morsels. Farmers welcome this service because they know where the VEW will be at what time and that the VEW will offer practical, current advice.

The VEW focuses on selected contact farmers, not to favor a few, but to make the widest possible immediate impact. Contact farmers

should not be the community's most progressive farmers, those viewed as exceptional. But neither should they be the least progressive, those unwilling to try something new. Contact farmers should have the respect of their peers -- the local community should help to select contact farmers.

Each contact farmer is asked to share recommendations as they are received with several neighbors, thus spreading discussion of them immediately. Contact farmers also serve as examples for those who watch what they do and see the results.

The VEW emphasizes the use of available resources and improved managing techniques, rather than use of increased purchases of inputs, concentrating on the kind of advice desired by the majority of farmers in the area at the time. The VEW rigidly adheres to the schedule of visits with contact farmers (the same time of the same day every one or two weeks) and encourages the contact farmer to invite others to attend. With some crops, the VEW recommends that the farmer limit using recommendations to a small portion of his field, thus

reducing the farmer's risk and providing a comparison with traditional methods. In addition, the VEW provides advice on availability and price of supplies and credit and informs suppliers and lenders of estimated demand.

Most important, the VEW concentrates on obvious production gaps, filling them first for immediate, observable results. This is best done by having all VEWs in an area attend weekly or bi-weekly (fortnightly) training sessions to confer with supervisors, technical experts and perhaps lenders or suppliers, on the best recommendations for the following two weeks.

### Contact Poultry Farmers

Depending on local circumstances, you can apply this system, either formally or informally, to your situation. As you begin forming a good picture of local poultry practices and the most obvious production gaps, you can



consult with others and identify contact farmers. They may be:

- Inexperienced with poultry-- While the farmer's potential risk and your responsibilities may be greater, you won't have to overcome traditional but inefficient management practices.
- Experienced with poultry-- With experienced farmers, you should know their history and the current condition of their flock and review with them how they can improve. If, for example, the farmer has lost between one and two percent of the flock per month, there may have been a feed, disease or other problem, but the flock may have potential. If mortality has been much higher, the flock may have less potential for recovery, especially as layers. If there are only a few runts (distinctly smaller than hatching mates) in the flock, the farmer can remove the runts and work with the rest of the flock. If 20 percent or more are runts, the flock probably will not be a good one to work with. In selecting contact farmers, it may be helpful to review with them from a form similar to the Farmer Specific Assessment Criteria sheet (see Appendix C).

## Timing of Suggestions

Once you have identified a contact farmer or farmers and they and you have arrived at a mutually agreed upon general plan, it is important to discuss specific management techniques to receive attention during the next two weeks. If a farmer expects a shipment of chicks in a week, talk about brooding, not egg storage. If the flock shows signs of severe coccidiosis infestation, talk about treatment, not about improved feeds. If local custom permits, try to involve all family members who actually work with the flock.

## Training

In many countries, veterinarians and laboratories are more concerned with other livestock than with poultry. Even poultry specialists may have so many other duties that they have very little time for field work. A good poultry

extensionist can help take their place in the field by consulting with them and calling for their services only when most needed.

For instance, extensionists in an area may agree that coccidiosis is a severe local problem that should be emphasized in the coming weeks. That is the time for them to invite or go to an expert for a short course on treatment of the disease. In the next two weeks, the extensionists work with farmers on the coccidiosis problem, thus learning practical applications of the theory thoroughly. The farmers should see immediate improvement and the specialists can tackle other areas or problems.

If there are no other poultry extensionists in your area, and information sources are far away, you can create your own in-service training program, reading as much as you can, writing to people who may have answers to local problems and visiting successful poultry operations. If you have no previous poultry experience, you should seek out places where you can gain actual

experience in:

- recognizing sick chickens
- coccidiosis and other disease control
- culling of layers
- performing a post mortem examination
- debeaking
- forced molting, when appropriate.

## Special Poultry Projects

If your primary assignment is something other than poultry extension, you still can be helpful in increasing local interest and involvement in poultry production.

Teachers may have much to offer, both to their students and the community. Biology teachers can use old hens for dissection studies, explaining how the various organs work and how embryos develop within the eggs. If a thermostat is available, the class can make and use an incubator and a candler, obtain

fertile eggs (perhaps from the students' family flocks), keep records of temperatures and turning, and, if accepted by local custom, open an egg or two every few days to see various stages of embryo growth. Math and economics teachers can use poultry examples in their exercises with students. Home economics and nutrition agents and teachers can explain and demonstrate ways of preparing eggs and poultry meat. Chemistry teachers can perform simple analysis of feed ingredients with their students if a laboratory is available. The possibilities are almost limitless.

A school flock of broilers could be an excellent 8-12 week project. If properly managed, the students should be impressed by the birds' growth, and carry some ideas back to their parents. The project could be culminated by a school and/or community dinner, by students taking chickens home or by selling the birds in the market.

A variation of the school flock project would be to conduct nutrition studies, having students mix

different rations and feeding them to separate small groups of birds starting with day-olds. The effects of various qualities of rations should become evident in two or three weeks. It may even be possible to obtain some started pullets and conduct studies in egg production, either to supplement the students' diets or for sale.

Those working in small business development in poultry raising areas may find the situation is ripe for developing or assisting a poultry or egg cooperative, or helping groups of farmers with their accounting and marketing problems.

People, such as Peace Corps Volunteers with training in chemistry and nutrition, can help analyze feeds being used and devise low-cost improvements.

Anyone with ingenuity, organizational ability and perseverance, no matter what his or her background, can become involved in projects such as:

- Market promotion--To help deal with seasonal surpluses. Example: a Volunteer in India helped a youth club

open a successful shop selling omelets and cold drinks during the hot season when many people otherwise could not eat eggs.

- Pest eradication--To improve conditions for everyone, not just poultry farmers. Study local traditions before you start such a project.
- Grain storage--This also could benefit everyone, not just poultry farmers.
- Feed production--Helping grow and process grain and other agricultural products while keeping in mind the use of by-products as chicken feed.
- Use of manure--In some areas, chicken manure is wasted. Help compost it and use it on a demonstration garden, build a model methane gas generator or use the manure to fertilize fish ponds.
- Extension publications--Concise publications in the local language that explain how farmers can improve the management areas under their control can be very helpful. Often feed suppliers, breeding companies or others will help pay for such publications, either through complete sponsorship or by advertising in them.
- Model equipment--Small-scale cardboard or paper models of houses, feeders, waterers, etc., can help you or others

in the design and construction of the actual item and also serve as excellent visual aids for extension.

Information needed for many of the above projects is contained in Peace Corps' Information and Collection Exchange publications, available in your local Peace Corps office or through ICE. You can help small farmers benefit from that information and provide feedback on the accuracy and usefulness of materials. Sometimes the most valuable contribution a Peace Corps Volunteer can make is to make farmers aware of the broad network of resources available to them.

# Appendix A: Housing Designs

It is unlikely that any two farmers will have night shelters or any other poultry structures which look exactly alike. In building construction there must be sufficient overhang to prevent rain from entering the building even in windy weather. But the overhang must not interfere too much with ventilation. Usually a three foot overhang is about right

for poultry houses where the bottom of the window isn't more than four or five feet below the point where the roof meets the wall. In hot climates, the overhang helps shade the interior of the building. The window can go right up to the point where the wall and the roof meet if the local climate is not very windy (15 - 20 miles per hour). The total

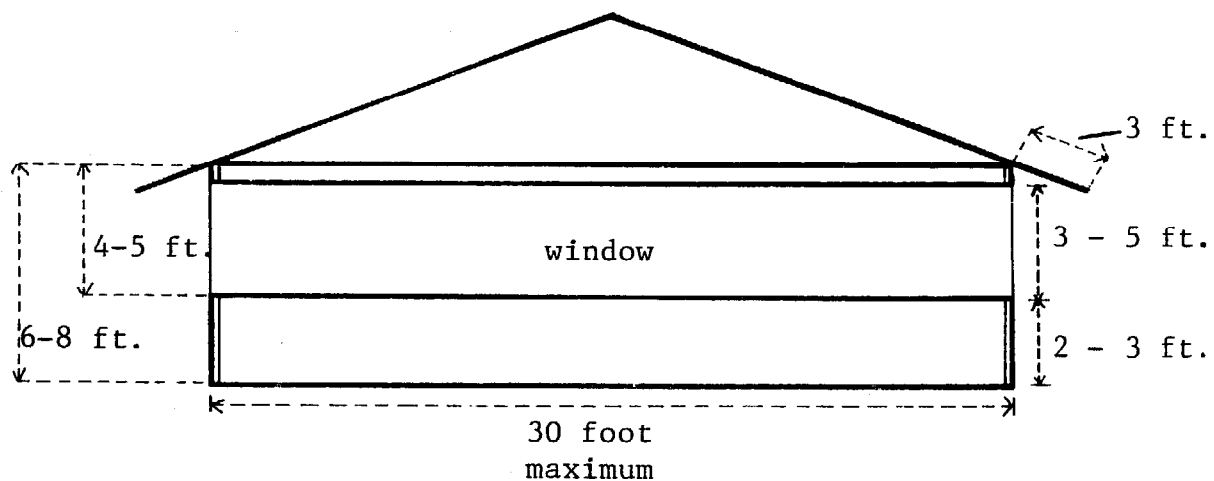

height will be determined by the width of the building. The wider the building, the higher the wall must be to allow increased ventilation area. A building 15 to 20 feet wide should have windows at least three feet high for most locations. A building 25 to 30 feet wide should have windows five feet high. Windows should extend the full length of the poultry house.

For severe weather conditions,

especially high winds accompanied by rain, buildings may have a hinged attachment which can be swung down. It can be a permanent part of the building or a weighted bamboo mat attached to the roof structure. An alternative to this is a woven bamboo mat tied securely to the lower part of the window area.

These fixtures also can be used to permanently correct improperly designed buildings where there are consistently strong winds.

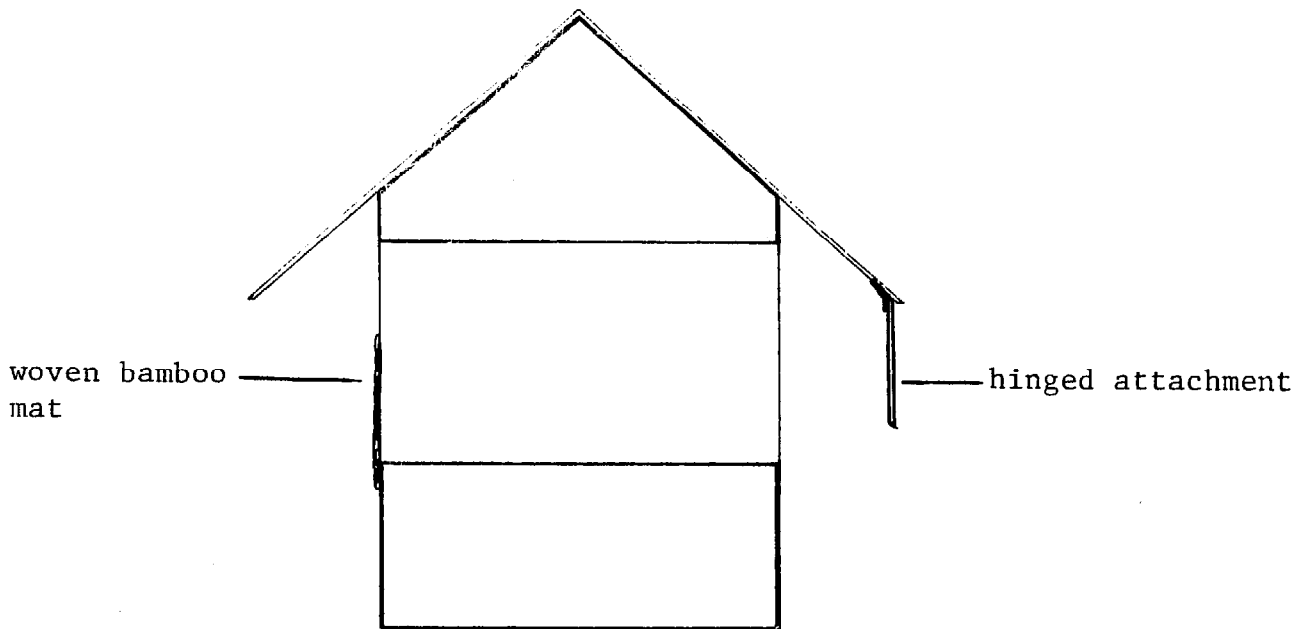

End of building -- In order to avoid rain entering the building, it is best to have the entire end closed,

except for a screened vent just under the roof gable.

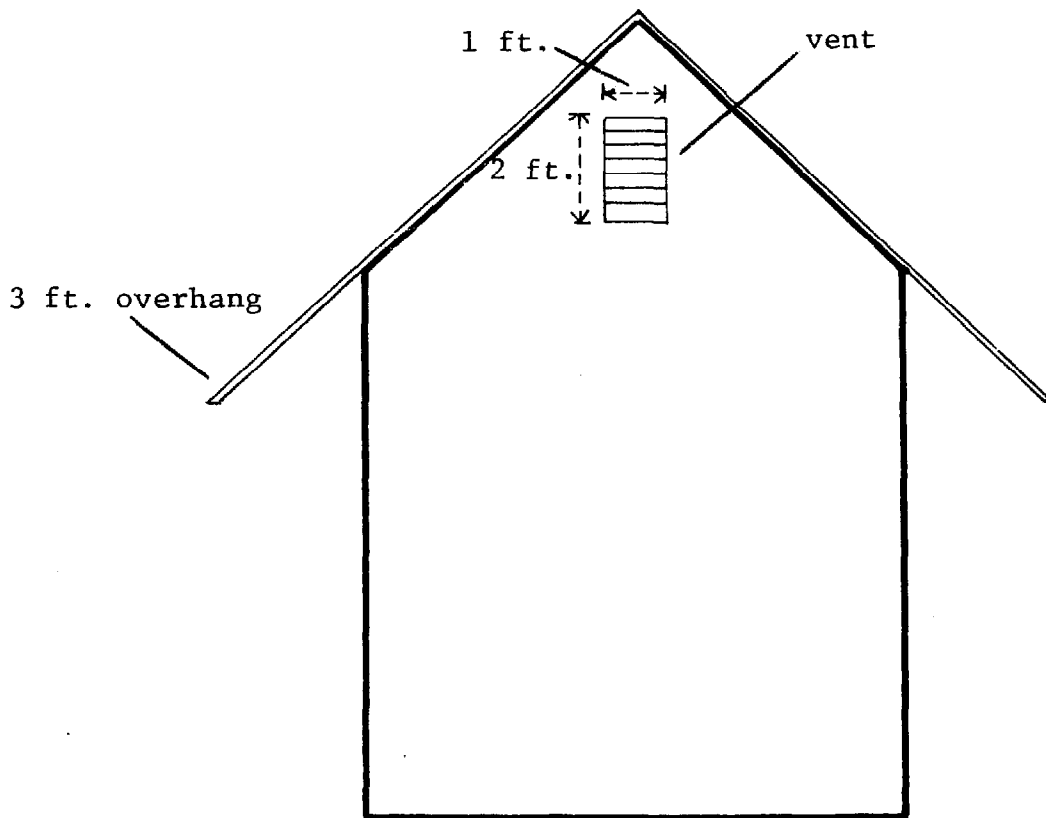

The vents serve to allow hot air to rise and escape and should be about one foot wide and two feet

high. The overhang over the vents must be adequate so that rain does not enter.

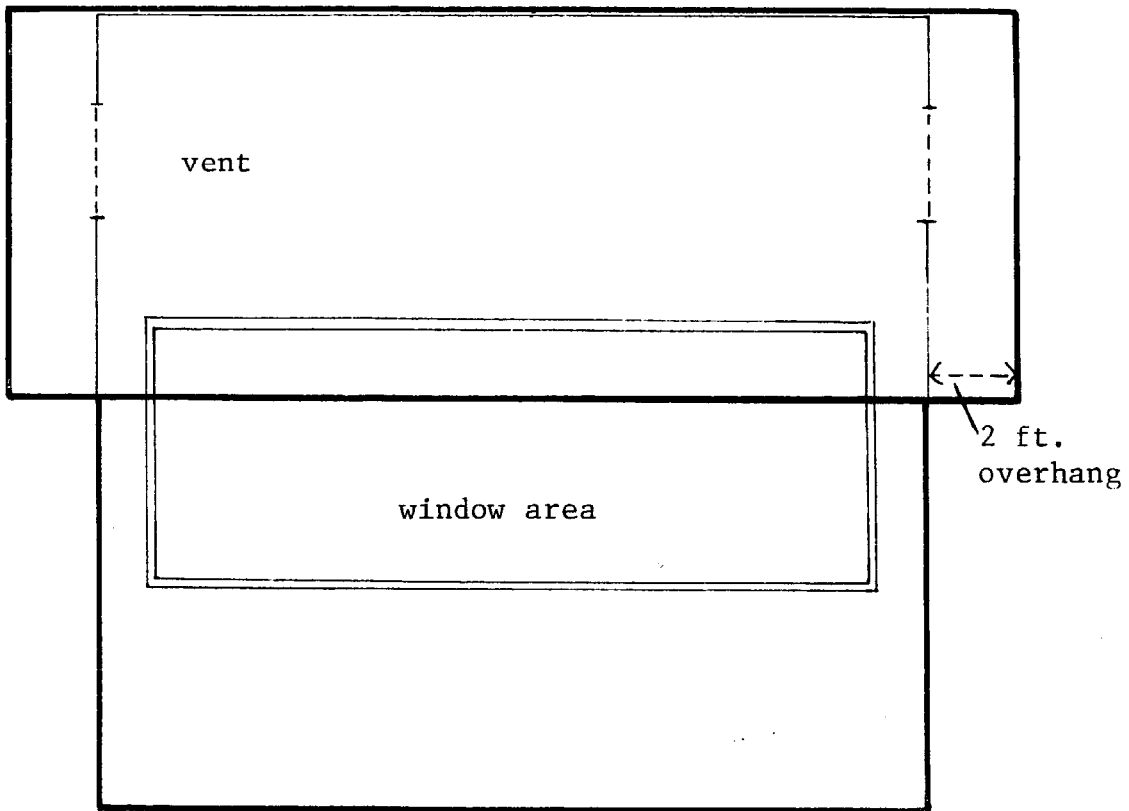



## Night Shelter

Night shelter for 20 country chickens attached to family house or other structure. Allow about

933 sq. cm (1 sq. ft.) per bird.  
Use deep litter or keep floor clean. In areas with heavy rains allow a generous roof overhang.

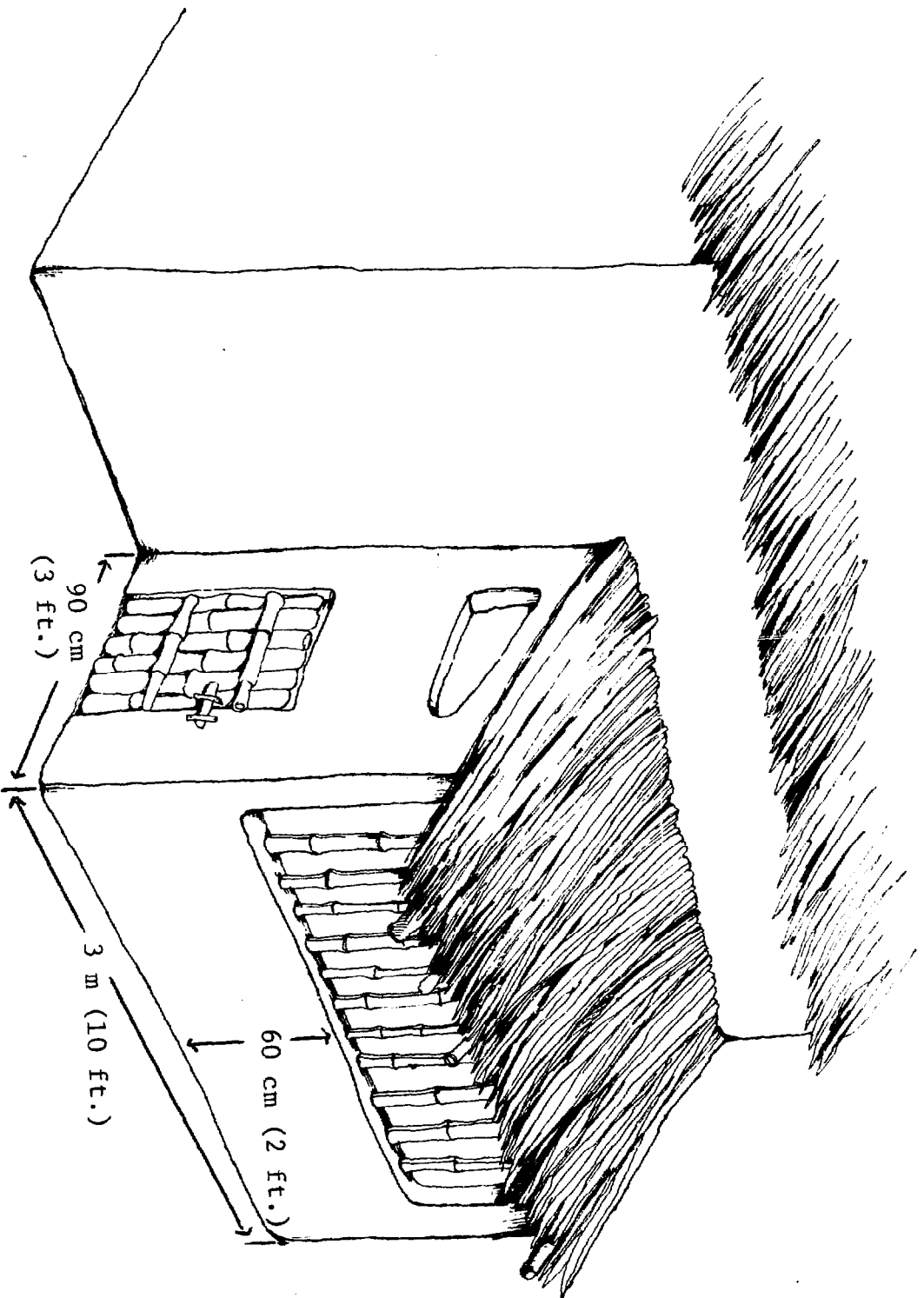

## Raised Floor House

Interior structure of raised floor house for 59 broilers or 25

layers. For use in hot, humid climates. Cover floor with bamboo or wood slats and enclose house with wire mesh, or wooden or bamboo slats.

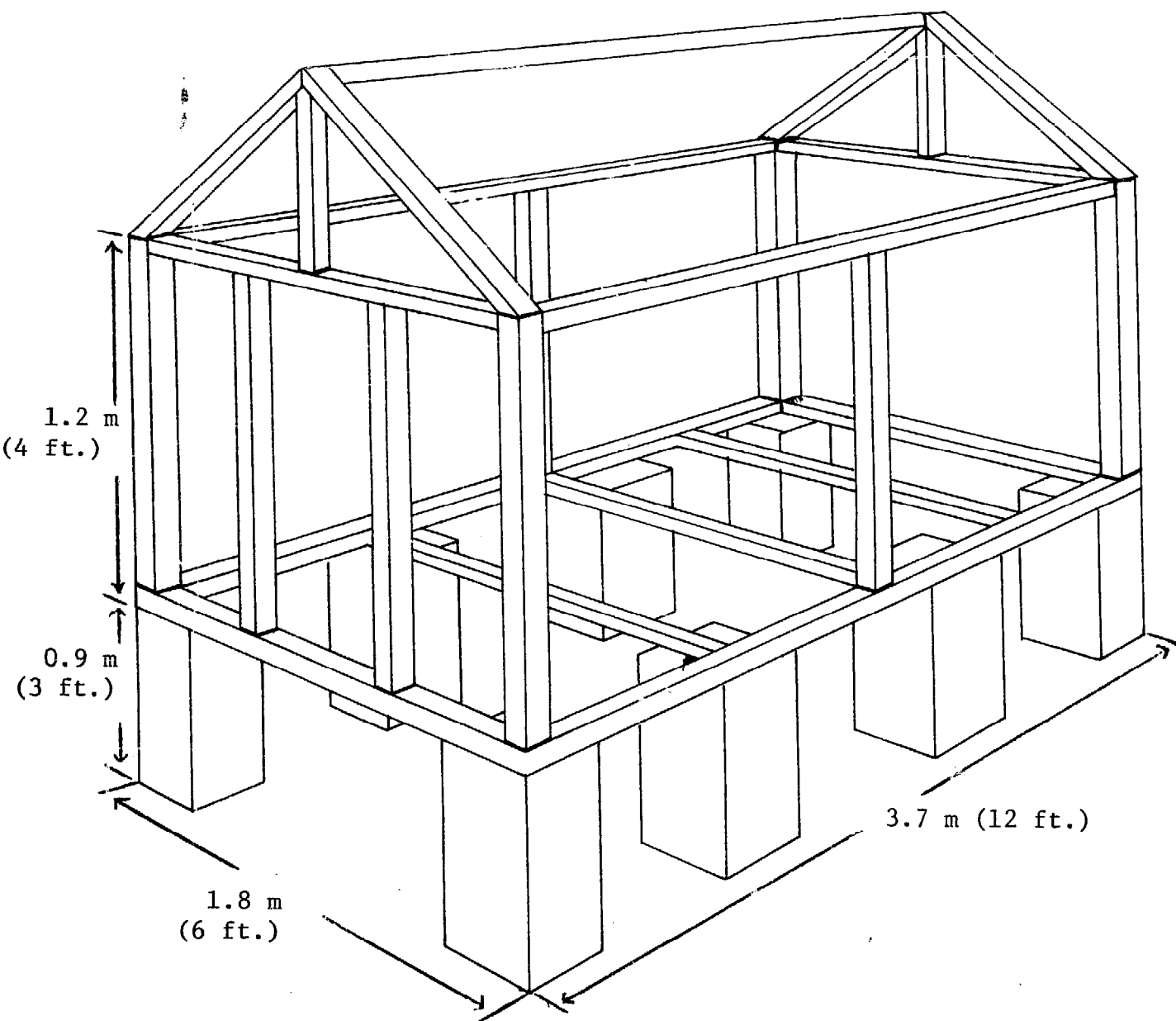

## Deep Litter House

Cut-away view of deep-litter house for warm climates. Enclose

in wire mesh or wooden or bamboo slats. This house can hold 200 broilers or 100 layers.

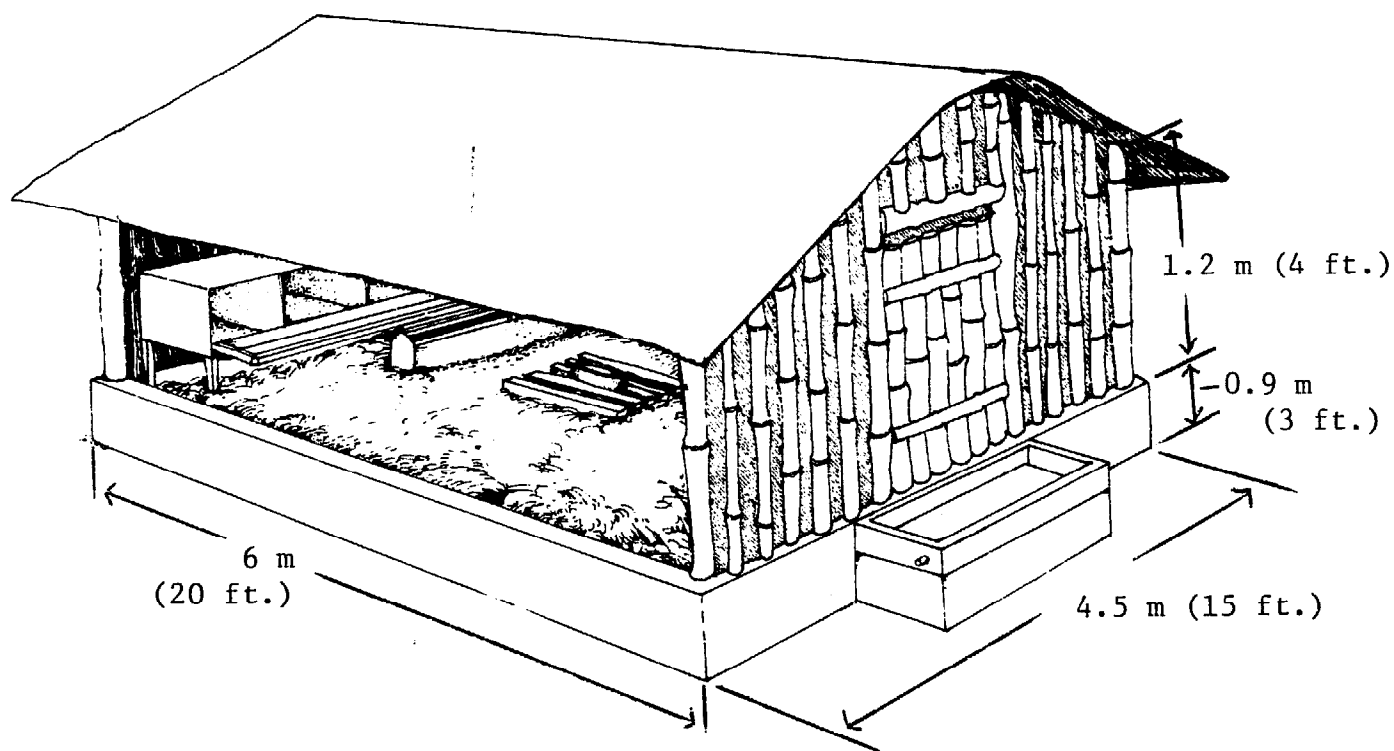

## Pole-type House

Pole-type laying house for 50 to 75 layers. The roof framing can be assembled in two sections, raised into position and secured to the poles. Sheeting may be plywood

or any available local substitute. Leave small slot openings between rafters at both the front and rear eaves for ventilation. Cover windows with plastic, mats, burlap, etc., during cold weather.

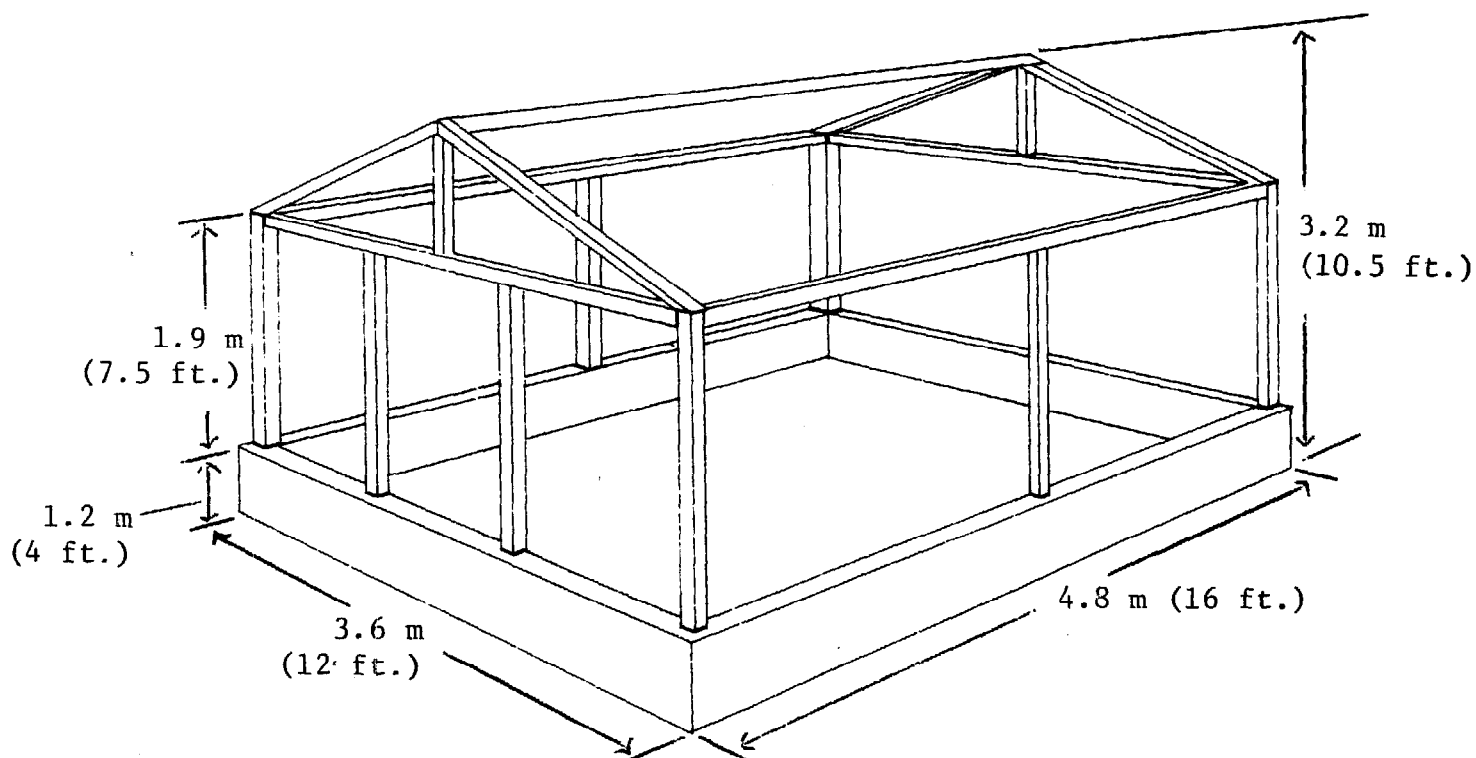

## Kerosene-Heated Incubator

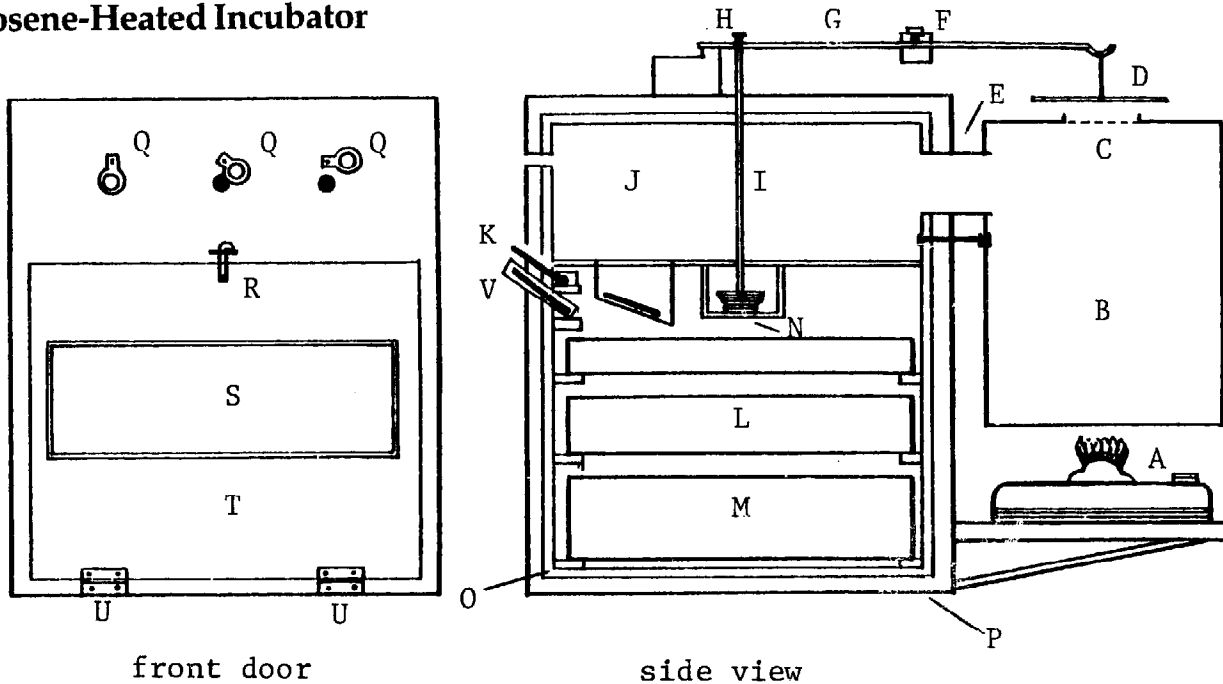

front door

side view

### Key

- |                                                                                                                                                                                                                                                                                                                                                                                                                                                                                            |                                                                                                                                                                                                                                                                                                                                                                                                                                                                                                                                                                    |
|--------------------------------------------------------------------------------------------------------------------------------------------------------------------------------------------------------------------------------------------------------------------------------------------------------------------------------------------------------------------------------------------------------------------------------------------------------------------------------------------|--------------------------------------------------------------------------------------------------------------------------------------------------------------------------------------------------------------------------------------------------------------------------------------------------------------------------------------------------------------------------------------------------------------------------------------------------------------------------------------------------------------------------------------------------------------------|
| <p>A. Kerosene lamp, 200 watt light bulb or other heat source.</p> <p>B. Tin can, about 30 cm (12 in.) in diameter.</p> <p>C. Exhaust, about 10 cm (4 in.) in diameter.</p> <p>D. Damper fits snugly over exhaust hole.</p> <p>E. Heat inlet, about 7.5 cm (3 in.) in diameter.</p> <p>F. Weight: slide towards heat source to increase internal temperature; away to decrease.</p> <p>G. Hinged arm suspends and moves damper.</p> <p>H. Set screw joins arm and rod from thermostat.</p> | <p>I. Rod connects thermostat and arm.</p> <p>J. Chamber, sheet metal bottom, sealed and vented.</p> <p>K. Dry Bulb thermometer, accurate in 35° C (95° F) to 40.5° C (105° F) range; bulb of thermometer about 1.25 cm (1/2 in.) above eggs.</p> <p>L. Egg tray, 60 x 60 cm (2 x 2 ft.) for 100 eggs; 43 x 43 cm (17 x 17 in.) for 50; made of sheet metal, or wood with fine wire mesh bottom.</p> <p>M. Water pan, sheet metal.</p> <p>N. Thermostat, liquid or gas-filled disc that expands with rising heat, contracts with falling -- usually purchased.</p> |
|--------------------------------------------------------------------------------------------------------------------------------------------------------------------------------------------------------------------------------------------------------------------------------------------------------------------------------------------------------------------------------------------------------------------------------------------------------------------------------------------|--------------------------------------------------------------------------------------------------------------------------------------------------------------------------------------------------------------------------------------------------------------------------------------------------------------------------------------------------------------------------------------------------------------------------------------------------------------------------------------------------------------------------------------------------------------------|

- O. Insulation -- optional, depending on cabinet materials.
- P. Cabinet, of soft wood (for insulation value) or two sheets of veneer or metal filled with sawdust, rice hulls or other insulation.
- Q. Vents, in front and back of cabinet, help adjust internal temperature and humidity.
- R. Latch, holds door closed.
- S. Window of glass -- optional.
- T. Door, wood or insulated sheet metal.
- U. Door hinges.
- V. Wet Bulb thermometer, to measure humidity.

# Appendix B: Other Poultry

## Ducks

Domestic ducks often are much easier to care for than chickens, for they are hardy, disease-resistant foragers. There are three principal breeds: Khaki Campbell for eggs (lays 300 to 350 per year for three or four years under good management); and Aylesbury or White Pekin for meat, reaching 3 kg (7 lbs.) or more at seven weeks of age. Muscovy ducks, the most common birds in villages, are larger than true ducks (sometimes Muscovies are classified with geese). Older Muscovies have enlarged, unfeathered skin on their faces. Mallards (male has green head), normally found wild, also are raised, but are smaller than

domestic breeds.

Due to the strong taste of duck eggs, local acceptance varies widely from area to area. Duck eggs are larger than chicken eggs and spoil more quickly (in about a week). Muscovies seldom produce more than 60 to 90 eggs per year, depending on their age.

Ducks can be raised using the same equipment as chickens. Waterers should be deep enough for them to submerge their heads (the same is true for geese). Ducks are very messy; great care should be taken if they are raised on deep litter. Ducks are more resistant to coccidiosis than chickens and tolerant to cholera. (Cholera can be transmitted by ducks to chickens, however.)

Farmers usually keep one drake (male) for every two females. Duck

eggs take 28 days to hatch; Muscovies take 35. Opinion is divided on whether ducks make good mothers (Muscovies do), so many people use broody hens to raise ducklings. As in the case of a broody hen hatching chicks, keep water near the hen.

If you use a brooder for ducklings, set it at 32.2° C (90° F) for the first week, and reduce it by 2.8° C (5° F) each following week. During their first four weeks, ducklings should be kept warm and dry. In their early weeks the ideal feed is starter pellets, although moistened mash, whole grain and/or fresh greens will do.

Once outside, ducks do well on grasses and insects, and will keep a mature garden free of snails and slugs. Don't let them in a growing garden -- they will devour it. They need no supplemental feed, but a few handfuls of grain scattered or placed in a trough in the evening will keep them nearer the house. When catching ducks or Muscovies, hold them by the wings, not the legs. Ducks can be held by the neck without

any discomfort to them.

Ducks are difficult to pluck, but their feathers often are valuable; melted wax helps in plucking (see geese).

## Geese

Domestic geese are raised for their meat, large eggs, feathers, and sometimes their ability to weed crops or act as watch dogs. They are large, hardy, aggressive, noisy birds that need little attention when mature and may live for 30 years. There are at least nine recognized breeds of domestic geese. Of them, the Chinese and African do best in the tropics.

African -- distinctive black knob on the head; black bill; light brown head; ash brown wings and neck. Good layer, but dark pinfeathers make it an unattractive meat bird. They produce about 45 - 90 eggs per year.

Chinese -- two varieties -- brown and white; smaller, more swan-like than other breeds. Good layers -- 40 to 65 eggs per bird per year.



Geese Weights

<u>Breed</u>	<u>Weight - 1 year old male</u>		<u>Weight - 1 year old female</u>	
African	9 kg	20 lbs.	8 kg	18 lbs.
Chinese	5.5 "	12 "	4.5 "	10 "
Toulouse	12 "	26 "	9 "	20 "
Emden	12 "	26 "	9 "	20 "

Toulouse --loose-feathered; broad, deep body; pale orange beak, dark grey back shading to white breast, deep orange shank and toes. They produce about 35 to 50 eggs per year.

Emden -- tight feathered: white body. Egg production averages 30 to 40 per year under good management.

Geese mate selectively and for life. Flocks should have at least one gander (male) for every two females.

Geese like swimming, but do not need to do so to breed. Eggs can be hatched by the mother, or by a female chicken which can care for up to six goslings (chicks). Keep eggs under a hen moist, and mark them and turn them each day, as they are too big for a hen to turn.

No brooder is needed for goslings, but they should be kept warm and

dry for the first few weeks. If housed, allow 0.09 sq. m (1 sq. ft.) per bird by two weeks of age on deep litter. Larger feeders and waterers are needed for goslings than for young chickens. Goslings do not need housing after six weeks.

Ideally, feed geese a 20 to 22 percent protein starter feed in pellet form. They can go on range from two to six weeks of age. A 1 m (3 ft.) fence will confine them. If pasture is plentiful, geese do not need more than 0.5 - 1 kg (1 - 2 lbs.) supplemental feed per bird per week, and then only until they are 12 weeks old. Provide grit through growing period.

Geese are selective grazers; they will not eat tough, dry grasses and some other plants. Thus, they can be confined in orchards, vine-

yards and in fields of strawberries (until blossom time), sugar beets, maize (once shoots have toughened), cotton and some other crops. Start with 6-week-old goslings, provide shade and water and give them a little grain in the evening if weeds and grass aren't abundant.

Most geese are marketed when they are five to six months old and weigh 5 to 7 kg (11 to 15 lbs.), depending on breed. Geese are difficult to pluck; often they are dipped in melted wax, the wax allowed to harden and the feathers and wax removed together. Remelt and reclaim wax, wash feathers in solution of detergent or borax and washing soda (sodium carbonate). In some areas, goose down (small feathers) fetches a good price in the market.

## Guinea Fowl

Guinea fowl originated in Africa where there are a number of wild species. In ancient times, Greeks

and Romans raised them as meat birds, and today they are prized by some people for their tasty meat, which competes favorably with wild game birds in price.

There are three varieties of domestic guinea fowl: pearl guinea (purplish grey with white flecks); lavender guinea (light grey or lavender with white flecks); and white guinea (all white). The most common is the pearl guinea.

Guinea fowl are more difficult to raise profitably than chickens because they are wilder -- they hide their eggs and do not take containment well. They may mate with chickens, but the offspring are sterile.

It is difficult to distinguish male from female guineas. Males have a slightly larger helmet (comb) and wattles, and a coarser head, but this is hard to see. Most people listen to their voices: the female call sounds like "buckwheat, buckwheat"; the male has a one-syllable shriek -- but since the flock usually all call at once, sex differentiation still is diffi-

ult. In the wild, guineas mate in pairs. In controlled flocks one male usually is kept for every four or five females.

Guinea keets (chicks) may be raised by their mothers, but a broody hen usually does a better job, sitting on the eggs until most are hatched (about 28 days), keeping the keets out of wet grass, and perhaps teaching them to enter the chicken shelter in the evening. Eggs also may be artificially incubated at 37.4° C (103° F) in a still-air (no fan) incubator for the first three weeks, and 40° C (104° F) for the last week. If you use a brooder, keep the temperature at 37.8° C (100° F) for the first week, and reduce by 2.8° C (5° F) each week thereafter.

Ideally, keets should have a 20 percent protein starter mash until six weeks of age and then should be switched to a 15 percent grower mash supplementing the feed they find on range. Feed in the late afternoon when they return to the shelter at night.

Guinea eggs are smaller than

chicken eggs, averaging 40 g (1.4 oz.). A well-managed hen may lay 100 eggs a year. Collect all but two or three from a nest when you find it, so that the hen feels safe in returning to it, and don't disturb her while she is laying.

Guineas usually are 16 to 18 weeks old when sold for meat. At that age they weigh 1.25 to 1.5 kg (2-3/4 to 3-1/2 lbs.).

## Turkeys

Originally a hardy bird of the North American forests, turkeys have been developed into many meaty but difficult-to-breed varieties, mainly the Bronze and the White. You can still order turkeys that are closer to the wild cousin -- they have much less breast size and thus, can breed more easily. The new breeds are stupid birds, prone to panic and stampede at the slightest actual or imagined provocation. They can run into walls or fences and break their necks or

pile into corners and smother. Poults (chicks) may starve to death unless they are taught to eat and drink. Very large turkeys often are too fat to mate and must be inseminated artificially.

Turkeys also are more susceptible to disease than chickens. They catch cold easily and are subject to coccidiosis, fowl pox and parasites, but their most dangerous disease is blackhead (lethargy, loss of appetite, yellow diarrhea, head darkens, death). Turkeys should be raised well away from chickens unless the farmer has much experience with both species.

In turkey flocks, one gobbler (male) is needed to breed with each ten hens. Eggs take 26 to 28 days to hatch. Watch the gobblers -- they often try to break the eggs.

Hatching and brooding turkeys artificially is a difficult business. A broody chicken will do a good job, but that increases the chance of disease. Turkeys are susceptible to two protozoan diseases: coccidiosis and blackhead; the chicken only to coccidiosis. Eggs under chickens

must be hand turned. Poults need a 28 percent protein starter feed and larger equipment than chickens. All-in-all, it is better, if possible, to buy poults when they are six to eight weeks old.

Growing turkeys need exercise on range and plenty of grass, supplemented with grain and protein. When confined, they may eat up to 45 kg (100 lbs.) of well-balanced feed by 24 weeks of age when they will weigh 4.5 to 8.2 kg (10 to 18 lbs.).

## Pigeons

Once a flock of pigeons is established, they can be practically self-sustaining. The common Rock pigeon, the one that throngs city parks, can be kept, but better, larger breeds are the White King and Giant Homer.

Any waterproof, easily cleaned house will do, as will an unused portion of a shed. In dark corners of the house, place nesting shelves

with lips so that the eggs don't roll off. Cats, dogs, snakes and rats eat pigeons, so place the house on legs or poles.

Pigeons stay close to home, so they don't need containment. If they are contained, give them well-balanced chicken feed. Treat them for parasites and coccidiosis as you would treat chickens.

A breeding pair will produce ten or more squab (young pigeons) each year, two at a time. Squabs usually are eaten when they are 25 to 30 days old, when they are completely feathered but have not begun to fly. At that age they weigh 400 to 680 g (14 to 24 oz.). A mature pigeon may live 12 years or more and may weigh 800 g (1-3/4 lbs.).

# Appendix C: Farmer Specific Assessment Criteria

Date:

1. Farmer name:
2. Location:
3. Number of birds:
4. Age of birds:
5. Breed source: Meat:
6. Feed source:
7. System of operation:
8. History of prior advisory assistance received:
9. Visual appearance of birds:
10. Number of years farmer has kept chickens:
11. Other:
12. Other:

Eggs:

#	SUBJECT	Existing	Potential	Gap/Comments	Ref. Page #
13.	Breed Souce Egg production Meat production Body weight avg.				
14.	Feeding/Nutrition a. Nutrition b. Feeding equip. c. Water equip. d. Layout e. Grit/shells f. Feed storage g. Feed sources				

#	SUBJECT	Existing	Potential	Gap/Comments	Ref. Page #
15.	Disease & Control a. Vaccinations - Newcastle - Fowl pox - Marek's - Inf. bronch. - Other b. Coccidiosis c. Other disease d. Antibiotics				
16.	Parasite Control a. Internal b. External				
17.	Cannibalism				
18.	Rodents, Wild Birds & Predators				
19.	Nesting Prov. a. Space B. Mgt.				
20.	Brooding/Rearing a. 1 day to 8 wks. b. 8 to 20 wks.				
21.	Mgt. Systems a. Range b. Deep litter c. Cage d. Slatted floor				
22.	Layer mgt. a. Stress b. Other				
23.	Housing a. Range b. Deep litter c. Slatted floor d. Cage				

SUBJECT	Existing	Potential	Gap/Comments	Ref. Page #
<ul style="list-style-type: none"> <li>. General Mgt.               <ul style="list-style-type: none"> <li>a. TLC                   <ul style="list-style-type: none"> <li>- Interest</li> <li>- Routine</li> </ul> </li> <li>b. Sanitation                   <ul style="list-style-type: none"> <li>- All out/in</li> <li>- Cleaning</li> <li>- Isolation</li> <li>- Hygiene</li> <li>- Dis. dip.</li> <li>- Feed storage</li> </ul> </li> <li>c. Daily sanitation                   <ul style="list-style-type: none"> <li>- Waterers</li> <li>- Feeders</li> <li>- Litter/droppings</li> </ul> </li> <li>d. Cost reduction                   <ul style="list-style-type: none"> <li>- Egg collection</li> <li>- Feed wastage</li> <li>- Space use</li> <li>- Culling</li> <li>- Upkeep</li> <li>- Keeping males</li> <li>- Joint efforts</li> </ul> </li> </ul> </li> </ul>				
<ul style="list-style-type: none"> <li>. Sex Separation</li> </ul>				
<ul style="list-style-type: none"> <li>. Stress Reduction               <ul style="list-style-type: none"> <li>- Disturbances</li> <li>- Feed changes</li> <li>- Caretaker changes</li> <li>- Routine changes</li> <li>- Violent weather</li> <li>- Moving birds</li> <li>- Dampness</li> <li>- Ventilation control</li> </ul> </li> </ul>				
<ul style="list-style-type: none"> <li>. Lighting</li> </ul>				
<ul style="list-style-type: none"> <li>. Marketing               <ul style="list-style-type: none"> <li>- Prices</li> <li>- Seasonal consid.</li> <li>- Yolk/shell color</li> </ul> </li> </ul>				



#	SUBJECT	Existing	Potential	Gap/Comments	Ref. Page #
	<ul style="list-style-type: none"> <li>- Egg cleanliness</li> <li>- Meat qualities</li> <li>- Egg grading</li> <li>- Meat grading</li> <li>- Handling &amp; storage</li> </ul>				
29.	Other <ul style="list-style-type: none"> <li>a. Incubation               <ul style="list-style-type: none"> <li>- Natural</li> <li>- Artificial</li> </ul> </li> <li>b. Country chicken               <ul style="list-style-type: none"> <li>- Breed improve.</li> <li>- Debeaking</li> <li>- Night protect.</li> <li>- Feeding</li> </ul> </li> <li>c. Forced molting               <ul style="list-style-type: none"> <li>- Methods</li> <li>- Economics of</li> </ul> </li> <li>d. Progress gauges               <ul style="list-style-type: none"> <li>- Body weight gain</li> <li>- Egg production curve</li> <li>- Uniformity of growth</li> <li>- Feed consumption</li> <li>- Mortality rate</li> </ul> </li> </ul>				

# **Appendix D: Feed Formulation Chart**

Key	Ingredient	Pounds in Mix	Protein		Fat	Fiber		Met. Energy		Calcium		Phosphorus	
			Amt.			Amt.		Kcal/lb	Amt.	Amt.		Amt.	
1	Alfalfa meal: 17%		.170*		.027		.260		490		.015		.002
2	Blood meal		.80		.01		.01		1400		.003		.002
3	Barley		.116		.019		.050		1205		.001		.005
4	Coconut oil meal		.20		.06		.12		675		.002		.006
5	Corn (maize)		.085		.035		.029		1530		.000		.003
6	Corn gluten meal:42%		.429		.023		.040		1475		.002		.004
7	Cottonseed meal: 44%		.440		.012		.110		910		.002		.011
8	Cottonseed meal: 41%		.416		.016		.110		1000		.002		.011
9	Cottonseed meal: 50%		.500		.001		.008		1010		.002		.014
10	Feather meal		.850		.030		.010		1078		.002		.008
11	Fish meal, anchovie		.650		.038		.001		1020		.045		.028
12	Fish meal, herring		.706		.075		.001		1350		.029		.022
13	Fish meal, menhaden		.600		.075		.001		1200		.050		.028
14	Fish meal, sardine		.650		.040		.001		1300		.045		.027
15	Limestone flour										.378		
16	Meat meal w/bone:45%		.450		.080		.025		780		.110		.050
17	Meat meal w/bone:50%		.506		.095		.020		870		.106		.051
18	Meat meal: 55%		.550		.080		.025		910		.080		.040
19	Peanut meal: 45%		.450		.068		.130		1100		.002		.006
20	Rice, broken		.073		.004		.004		1550		.000		.001
21	Rice bran (variable)		.125		.133		.130		1000		.001		.014
22	Rice polish		.110		.120		.034		1500		.000		.001
23	Sesame seed meal		.420		.070		.066		1200		.020		.013
24	Sorghum grain (milo)		.090		.028		.023		1500		.000		.003
25	Soybean meal: 42%		.420		.035		.065		1100		.002		.006
26	Soybean meal: 44%		.440		.005		.070		1020		.002		.006
27	Soybean meal: 50%		.500		.005		.030		1150		.002		.007
28	Wheat bran		.150		.030		.120		510		.001		.010
29	Brewers' dried yeast		.446		.011		.030		840		.001		.014
30	Dicalcium phosphate										.270		.191
31	Bone meal, straight		.121		.032		.020		421		.290		.136
32	Cassava (yucca, manioc) meal		.001		.001		.001		1597		.001		.002
33	Molasses		.030										
T	TOTALS												
V	VALUES FOR RATION												
AV	ADJUSTED VALUES												
AR	ALLOWANCES OR REQUIR.												

\* This means that in every pound of alfalfa meal there is 0.170 pounds of protein, and in every kilogram of alfalfa meal there is 0.170 kilograms of protein, and so on.





Key	Manganese		Sodium		Iron		Copper		Iodine		Potassium		Magnesium		Zinc	
	mg/lb	Amt.	lb/lb	Amt.	mg/lb	Amt.	mg/lb	Amt.	mg/lb	Amt.	lb/lb	Amt.	mg/lb	Amt.	mg/lb	Amt.
1	30.9		.002		191		7.7		.25		.020		545		15.9	
2																
3	8.3		.000		27		3.9		.02		.006		636		7.8	
4																
5	2.2		.000		13		1.8		.02		.004		771		5.5	
6	3.3		.001		181		12.8				.000		227		63.4	
7	9.1		.001		69		9.7		.05		.015		2633			
8	9.1		.001		69		9.7		.05		.015		2633			
9	9.1		.001		69		9.7		.05		.015		2633			
10																
11	4.5		.007		254		3.8		.48		.005		863		95.6	
12	4.5		.007		254		3.8		.48		.005		863		95.6	
13	4.5		.007		254		3.8		.48		.005		863		95.6	
14	4.5		.007		254		3.8		.48		.005		863		95.6	
15	117.1		.001		1680						.001		5221			
16	5.6		.007		227		0.7		.59		.006		5130		170.2	
17	5.6		.007		227		0.7		.59		.006		5130		170.2	
18	4.1		.007		254		3.9		.51		.006		852		97.4	
19	11.6		.016		72						.005		432			
20	2.5		.000		11		1.8		.02		.006		439			
21	25.4		.000		88						.008		511			
22	6.1		Trace		73						.021					
23	10.9		---		11						.022		1304		68.8	
24	6.6		.000		22		7.2		.01		.004		998		7.0	
25	12.5		.003		59		16.6		.06		.020		1226		66.4	
26	13.0		.003		61		17.1		.06		.021		1233		68.1	
27	13.9		.004		64		18.0		.07		.024		1264		71.4	
28	46.7		.002		44		8.5		.00		.013		2315			
29	2.6		.001		58		15.0		.00		.017		1044		17.6	
30											.001		13484		2.3	
31	13.8		.005		381		7.4				.002		2946		193.0	
32																
33																
T																
V																
AV																
AR																



# Appendix E: Feed Requirements

## Energy Requirements

	<u>0-8 weeks</u>	<u>8-20 weeks</u>	<u>20 weeks and on</u>
Metabolizable energy (ME)			
calories per lb.	1,250	1,280	1,335
calories per kg	2,750	2,815	2,950

## Vitamin Requirements

	<u>0-8 weeks</u>	<u>9-20 weeks</u>	<u>20 weeks and on</u>	<u>Breeding Chickens</u>
	(units per kg /lb.)			
Vitamin A <sup>1</sup>	2,640/1,200	2,640/1,200	4,400/2,000	4,400/2,000
Vitamin D <sub>3</sub> <sup>2</sup>	200/90	200/90	500/225	500/225
	(amount in mg per kg /lb.)			
Vitamin K	0.5/0.24			
Thiamin	1.7/0.8			
Riboflavin <sup>3</sup>	2.4/1.3	1.7/0.8	2.2/1	3.7/1.7
Panthenic acid <sup>4</sup>	9.2/4.2	9.2/4.2	4.6/2.1	9.2/4.2
Naicin	26/12			
Pyridoxin	2.9/1.3		2.9/1.3	2.9/1.3



	<u>0-8</u> <u>weeks</u>	<u>9-20</u> <u>weeks</u>	<u>20 weeks</u> <u>and on</u>	<u>Breeding</u> <u>Chickens</u>
Biotin	0.09/0.04			
Choline	1,320/600			

Vitamin E--Needed in feeds, but requirements unknown.

- Notes--1. International Units (IU).  
 2. International Chick Units (ICU).  
 3. Feeds only containing grain may not have enough riboflavin.  
 4. Feeds that have enough riboflavin usually have enough pantothenic acid.

### Protein and Amino Acid Requirements

(percentage of total feed)

	<u>0-8</u> <u>weeks</u>	<u>9-20</u> <u>weeks</u>	<u>20 weeks</u> <u>and on</u>	<u>Broilers - 0</u> <u>weeks to sale</u>
Crude protein	20	16	16-18	22
Amino acids				
<sup>2</sup> Arginine*	1.20	unknown	0.80	1.20
<sup>2</sup> Lysine*	1.10	0.70	0.50	1.10
<sup>2</sup> Methionine* (minimum)	0.45	0.35	0.28	0.45
<sup>1</sup> Cystine*	0.35	0.30	0.25	0.35
<sup>2</sup> Tryptophan*	0.20	0.18	0.15	0.20
Glycine	1.00	1.00	1.00	1.00
<sup>2</sup> Histidine	0.15	unknown	0.30	0.15
<sup>2</sup> Isoleucine	0.60	"	0.80	0.80
<sup>2</sup> Leucine	1.40	"	1.20	1.40

\* Many feeds do not have enough of these acids.

- Notes--1. Remember cystine is synthesized from methionine and is not essential unless methionine is limited.  
 2. The essential amino acids.  
 3. Tyrosine is synthesized from phenylalanine and is not essential unless phenylalanine is limited.

	<u>0-8 weeks</u>	<u>9-20 weeks</u>	<u>20 weeks and on</u>	<u>Broilers - 0 weeks to sale</u>
Phenylalanine (minimum)	0.90	unknown	0.70	0.90
Lysine	0.70	"	1.00	0.70
Threonine	0.60	"	0.55	0.60
Methionine	0.80	"	0.80	0.80

### Mineral Requirements

(percentage of total feed)

	<u>0-8 weeks</u>	<u>9-20 weeks</u>	<u>20 weeks and on</u>	<u>Breeding chickens</u>
Calcium	1	1	2.75	2.75
Phosphorus	0.60	0.60	0.60	0.60
Iron	0.50	0.50	0.50	0.50
Potassium	0.20	0.16	-	-

(amount in mg per kg /b.)

Manganese	55/25	-	-	33/15
Zinc	1.1/0.5	-	0.4/0.2	1.1/0.5
Copper	490/220			

Note--Mineral contents of a feed should not greatly exceed these levels;  
overuse of one may block utilization or digestion of another.

### Maximum Limits of Feed Ingredient Use

<u># Source</u>	<u>Percentage of total feed weight</u>
1. Alfalfa meal	5-10
2. Blood meal	4-5

<u># Source</u>	<u>Percentage of total feed weight</u>
3. Barley	20
4. Coconut oil meal (copra meal)	15-40 (depending on fiber content)
6. Maize (corn) gluten meal	15
7-9. Cottonseed meal	10-15
10. Feather meal	5-7
11-14. Fish meal	10-15
15. Limestone flour	4
5-18, 31. Meat and bone meals	10
19. Groundnut (peanut) meal	35
20. Rice, broken	30
21. Rice bran	10-15 (30% of high quality and low in fiber)
22. Rice polish	50
23. Sesame seed meal	30
25-27. Soybean meal	30
28. Wheat bran	15
29. Brewer's yeast	5-10
32. Cassava (yucca, manioc) meal	chicks - 10 layers - 20
Sweet potato meal	20
Wheat	50
Salt	0.5
Straw and rice hulls	0

# Appendix F: Bibliography and Resources

## Resources

### Peace Corps Publications

Several other Peace Corps manuals complement the material in this one. They may be obtained through the Peace Corps staff in your country, or by writing to Information Collection and Exchange, Peace Corps, Washington, D.C. 20525, U.S.A. They include:

Self-Help Construction of One-Story Buildings, Manual Number M6 (Peace Corps).

Small Farm Grain Storage Manual, Manual Number M2 (Peace Corps/VITA).

### FAO Publications

The United Nations Food and Agricultural Organization offers a number of helpful publications, some of which are listed below. They might be obtained through the FAO office in your country, or write: Unipub, Box

433, Murray Hill Station, New York, New York 10016, U.S.A. Enclosing payment, especially for orders of \$15.00 or less, saves postage and handling charges. In some cases ICE will provide them free of charge, to Peace Corps in-country resource centers or to Volunteers.

## Bibliography

Note on ordering--Most publishers listed below do not normally send books overseas by mail. It is a good idea to have someone in the U.S. order the books for you and forward them by mail. Otherwise, generously estimate the airmail postage and include it with your order. Prices are subject to change. In some cases you can order through your local Peace Corps office or through ICE.

### Chicken Husbandry

ABC of Poultry Raising, J. H. Florea. Dover Publications, Inc., 180 Varick St., New York, New York 10014, U.S.A., 1977, 142 pp. Although directed to farmers in northern temperate zones in industrialized nations, this book contains basic information needed to raise small- and medium-scale chicken flocks successfully. US\$4.00.

Poultry Husbandry II: Notes for students of animal husbandry, G. J. Price and J. E. Reed. FAO, 1971, 91 pp. Describes poultry management systems, housing and equipment. US\$2.00.

Poultry Keeping in Tropical Areas, W. Thomann. FAO, 1968, 56 pp. Manual intended for agricultural leaders in applied nutrition projects, and for rural poultry producers. US\$3.00.

Poultry Science, M. E. Ensminger. The Interstate Printers and Publishers, Danville, Illinois, 1971, 276 pp. This is one of several good textbooks covering all aspects of poultry husbandry with a United States perspective.

### Breed Source

1979-1980 Who's Who International in the Egg and Poultry Industries. Watt Publishing Company, Mount Morris, Illinois 61504, U.S.A., 204 pp. Contains breeder performance characteristics, world poultry production outlook, and an international buyers' guide in English, German, French, Italian and Spanish for poultry and products in 73 countries. US\$10.00.

The International Trade Development Board of the Poultry and Egg Institute of America, 1815 N. Lynn Street, Arlington, Virginia 22209, U.S.A., which cooperates with the Foreign Agricultural Service of the U.S. Department of Agriculture, will try to help you find layer chick suppliers with experience in breed requirements and import regulations in your country. They ask that you be as specific as possible about the objectives of your project, including the number of birds you desire, the housing plan, temperature conditions and medical and technical assistance available. Through their affiliation with the World Poultry Science Association, they also may be able to provide advice on unusual technical problems. Again, the more specific and detailed your request, the better they will be able to serve you.

### Breeding

Practical Poultry Breeding, D. C. Warren. MacMillan Company, U.S.A., 1966. A good book on basic poultry breeding principles.

The Genetic Basis of Selection, Lerner I. Michael. John Wiley and Sons, New York, New York, U.S.A., 1965. Another good breeding reference for those needing more detailed genetic information.

### Nutrition

Amino-acid Content of Foods and Biological Data on Protein. FAO Nutritional Studies No. 24, 1970, 285 pp. Tables show amino acid levels in 384 foods, plus data on biological value, digestibility, net protein

utilization and protein efficiency rate. Intended for use in human nutrition, but valuable for poultry as well. US\$15.00.

Poultry Feeding in Tropical and Sub-tropical Countries. FAO Agricultural Development Paper No. 82, 1965, 96 pp. Discusses special problems of feeding poultry in tropical countries and lists sample rations used in 36 nations. US\$4.50.

#### Marketing

Marketing Eggs and Poultry, G. F. Stewart and J. C. Abbott. FAO Marketing Guides No. 4, 1961, 194 pp. Reviews organizations, methods and services of marketing, with detailed information on quality standards, handling methods, packing and container specifications.

#### Feeds and Feeding

The Scientific Feeding of Chickens, Titus and Fritz. Fourth Edition. The Interstate Printers and Publishers, Danville, Illinois, U.S.A., 1972, 247 pp. An excellent source of information on principles of feed mixing and nutrition of poultry. It is found in most agricultural libraries around the world.

Poultry Feed Mixing Manual, Pran Vohra. U.S. Agency for International Development, New Delhi, India, 1962. This, and an edition revised by Peace Corps Volunteer Keith Pheuler, is by far one of the best introductions to practical feed mixing. Copies are available in the ACTION library.

Feeds and Feeding, Frank B. Morrison.

The Morrison Publishing Company, Ithaca, New York 14850, U.S.A., 1956, 1165 pp. An excellent source of information on feedstuffs, feed mixing and nutrition principles. Found in most agricultural libraries around the world.

#### Cooperatives

Training and Extension in the Cooperative Movement, A. F. Laidlaw. FAO Agricultural Development Paper No. 74, 1962, 78 pp. The author describes training and extension experience in India, concentrating on teaching methods.

#### Extension

Agricultural Extension: The Training and Visit System, Daniel Benor and James Q. Harrison. Publications Unit, World Bank, 1818 H Street, N.W., Washington, D.C. 20433, U.S.A., 1977, 57 pp. No charge for single copies. Probably the best booklet on extension.

Guide to Extension Training, D. J. Bradfield. FAO Economic and Social Development Series No. 6, 1966, 176 pp. Deals with teaching methods, social and cultural factors, evaluation, etc. US\$6.50.

#### Diseases

Salsbury's Manual of Poultry Diseases, Dr. Salsbury's Laboratories, Charles City, Iowa, U.S.A. This is a superior manual and one of a kind in quality in terms of functional value to the poultry extensionist. It is almost mandatory. This manual is condensed, filled with color photographs and covers most disease information essential to poultry work. Do

## Glossary

- Broiler -- Chicken grown for meat.
- Breeder -- Sexually mature chicken used to produce fertile eggs.
- Capon -- Castrated male chicken.
- Cockerel -- Male chicken less than one year old.
- Fryer -- Young broiler, usually less than one year old.
- Grower -- Intermediate stage between chick and adult.
- Hen -- Female chicken over one year old.
- Layer -- Female chicken, usually 21 weeks or older, kept for eggs.
- Pullet -- Female chicken less than one year old.
- Roaster -- Fat, heavy broiler, usually more than ten weeks old.
- Rooster -- Male chicken more than one year old. Also called cock.

# Index

- Advantages, poultry keeping, 3
- Aflatoxins, 115
- Air, 25, 89
- Air cell, 22, 53-55
- Amino acids and requirements, 131, 137, 204, 205
- Anatomy, external, 23, 24, 128-130
- Anatomy, internal, 25-27
- Antibiotics, 139
- Assessment
  - checklist, (Appendix C, 193-196), ii, 3-6, 9-20, 32-35
  - information sources, 18, 19, 26, 33, 166 (Appendix F, 207-210)
  - observation, 16, 17
  - country fowl, 33-35
- "Automatic" waterers, 103, 104
  
- Basket brooder, 60
- Battery cages, 15
- Blood, 24, 25
- Blood spots (eggs), see Candling
- Body weight, 2, 43-45, 155, 156, 193
- Breathing, 25, 89 (see also Diseases)
- Breeds, dual purpose, 44, 45
- Breeds (meat types), 44
- Breeds, layer types, 43, 44
- Breeds and breeding/sources
  - choosing a breed, 37-42, 44-46
  - classification, 2, 3, 43-45
  - country fowl, 37-39
  - improvement breeding, 37-39, 48, 49
  - dual purpose, 44, 45
  - layers types, 43, 44
  - meat types, 44
- Broilers, see Meat Chickens



Broiler management schedule, 56-65  
 Bronchial tubes, 25 (see also Diseases and Post Mortem)  
 Bronchitis, 120,121  
 Brood hens, 12, 47  
 Brooder designs, 58-61  
 Brooder guard, 60  
 Brooding, operation and management, 56-65
 

- preparation, 56
- hovers, 58-60
- temperatures, 60, 61
- feeders, 61
- waterers, 18, 62, 76, 77, 100-104, 139
- layout, 63
- houses, 86, 87
- country fowl, 36

 Broodiness, 12, 47  
 Budgets, 18, 33, 153-157, 161-168
 

- layers, 162, 163
- meat type, 157

 Buildings (see Housing)  
 Cages
 

- vs floor layers, 15, 66
- design and construction, 94-100

 Calcium, 66, 110, 138  
 Candler, 52  
 Candling, 54, 55  
 Cannibalism, 75-79, 87, 94  
 Caponizing, 37, 136  
 Carbohydrates, 37, 136  
 Castration, 2  
 Catching chickens, 28, 29  
 Ceca, 25, 122, 123, 130  
 Cecal coccidiosis, 122, 123, 130  
 Cecal worms, 5, 65  
 Chickens
 

- external anatomy, 21-24
- general information, 1-8
- getting to know, 21-29
- internal anatomy, 25-27

 Chick guard, 60  
 Chicks
 

- buying of and cost, 42, 45, 157, 162
- color of, 21-24
- country type, care of, 36, 55

- debeaking, 77-79
- feeding, 36, 61, 63, 104-108, 134, 137, 143, 155
- hatching of, 46
- improved breed management schedule, 56-65
- sexed vs unsexed, 45
- watering, 62, 100-104

Chlorine, 50

Cholera, 83, 116

Claw, 22

Coccidiosis, 64, 116, 122-124

Cocks, cockerals, 22, 37, 76

Colds, 116, 124, 125

Colony brooders, 59

Colony cages, 98

Colony nests, 112

Comb, 22

Confinement and range rearing, 35-36, 81-99

Control concept in management, of environment, 17

Cooperatives, 19, 168, 173

Coryza, 116, 124, 125

Country fowl, 2, 3, 10, 11, 31-39

Costs, 16

- broilers, 157, 166
- country chickens, 33, 154
- layers, 162, 163, 166

Crop, 25

Crop, impacted or bound, 57

Crowding, effects of, 87-89

Culling, 66, 72-74, 86

Cultural beliefs, 5, 32

Day length, 65-71, 76

Dead chickens, 66

- disposal of, 76, 128-130

Debeaking, 77-79, 94

Deep litter, 14, 56, 57, 75, 83, 84

Diagnosis of diseases, 65, 118, 128-130

Diarrhea (see Coccidiosis)

Digestive system, 25 (see also Nutrition)

Dipping, matching eggs, 50

Dirty eggs, 48, 111, 159, 160

Disadvantages, poultry raising, 3, 4.

Diseases, 115-130

- diagnosis, 65, 118, 128

- mortality rates, 76, 116
- nutritional deficiencies, 150-153
- prevention, 92, 115-130
- resistance, 2, 3, 39
- vaccinations, 116-121

Disinfectants, 52, 56

Disinfectant dip, 92

Down, 22

Drowning, 36

Dual purpose chickens, 2, 3, 44, 45

Ducks, 185, 186

Dust, 87

Ear lobes, 23

Economics (see Records, Finance, Marketing)

Eggs, 16, 17, 21, 26, 33, 38, 66

- breakage prevention/handling, 111, 112, 159
- candling, 52, 55
- cleaning, 48, 111, 159
- color of, 2, 43, 44, 66, 67
- dipping, 50
- grading, 159, 160
- hatching, 47-50
- production, 39, 67, 166, 167
- quality, 52-55
- storage, 159, 160
- thin-shelled, 66, 71, 77, 110, 138

Eggs, marketing of, 2, 6, 19, 20, 153, 154, 159-163

- eggs vs meat, 41, 42, 88, 89
- planning for, 6, 19, 20 34, 153
- seasonal considerations, 34, 167

Egg breeds, 2, 3

- buying and starting, 42-46, 56-65
- starting time, 34, 167

Egg shell hopper, 110

Embryo, 48

Energy in feed, 136, 137, 203

Energy, for equipment

- electric brooder, 58
- kerosene brooder, 59
- kerosene incubator, 183
- lighting, 65-71
- solar, 59
- wood, 59

Energy, from litter/methane gas, 37, 174  
Environment, 2, 22, 32, 75-79  
-- control, 17  
Equipment/materials, 81-114, 183, 184  
-- brooding and rearing, 58-63  
-- brooder,  
-- cages, 85, 94-100  
-- catching,  
-- cleaning, 56  
-- country chickens, 31, 35, 36  
-- debeaking, 77-79  
-- disinfectant dip, 92, 93  
-- egg candling, 54, 55  
-- feeders, 104-108  
-- feed mixings, 148, 149  
-- floor space, 87-89  
-- grit hoppers, 109, 110  
-- incubation, 48, 51  
-- layers, 65-67, 88, 89  
-- lighting, 67-70  
-- litter, 56, 57  
-- meat breeds, 65, 88, 89  
-- nests, 111, 113  
-- planning for, 18, 19, 193  
-- pullets, newly housed, 46, 66 (see Lighting)  
-- rat control, 79  
-- records, 164-166  
-- roosts, 113  
-- vaccination, 117, 118  
-- waterers, 100-104  
Erosion, gizzard, 84  
Esophagus, 25  
Examination,  
-- external, 22-24, 27-29  
-- internal, 25-27  
-- post mortem, 119, 128-130  
Extension, 169-174, 193-196  
--special projects, 172-174  
Eyes, 23 (see also Diseases)  
Farmer assessment (see Assessment)  
Farm location, 87  
Fats, 136  
Feathers, 22, 23

Feather mites, 126, 127  
 Feather pulling (see Cannibalism)  
 Feces, 25 (see Deep litter)  
 Feed (see also Nutrition)  
   -- concentrates, 147  
   -- consumption, layers, 66, 106  
   -- conversion, broilers, 155, 156  
   -- country chickens, 36, 37  
   -- deficiencies, 150-152  
   -- feeding, 61  
   -- formulation, 140-146  
   -- grinding, 149  
   -- ingredients, 131-152  
   -- mixing, 148  
   -- nutrients, 136-140  
   -- storage, 149  
   -- wastage, 77, 84, 104, 105  
 Females vs males, 2, 22, 24, 26, 37  
 Fertilized vs unfertilized eggs, 5, 22, 26  
 Fertilizer, 3 (see also Deep litter)  
 Finances, 18, 33, 153-157, 161-168 (see also Marketing)  
   --increasing profits, 104, 105, 166, 167  
   --sources of finance, 167, 168  
 Flock  
   -- sizes, 3, 4, 132, 161  
   -- upgrading, 37-39  
 Floor, flooring, 87-89, 92-97  
   -- deep litter, 15, 83  
   -- raised, 15, 84  
   -- cage, battery, 15, 85  
 Fly control, 58  
 Food poisoning, 57, 128  
 Foot, 22  
 Forced molting, 71, 72  
 Fowl cholera, 83, 120, 121  
 Fowl pox, 64, 65, 115, 120  
 Free range, 10-12, 81  
 Fryer, 2  
 Fumel, 26  
  
 Gall bladder, 26  
 Gap (existing vs potential), 16, 17, 33, 34 (see Assessment)  
 Geese, 186-188  
 Gizzard, 25, 109

ssary, 211  
in 134 (see also Feed)  
en feed, 31, 131, 134  
t, 109, 110, 139  
wer mash, 134  
wth rates, 155, 156, 158  
nea fowl, 188, 189

dling  
-- eggs, 111, 112  
-- chickens, 27-29

ching, 22, 46-55 (see also Incubation and Eggs)  
lth (see Diseases)  
t stroke, 76  
ting sources (see Brooding, Incubation)  
s (see Layers)

sing, 81-94, 175-182  
-- cages, 85, 86, 94-100  
-- construction, 86-94  
-- contained systems, 83  
-- country fowl, 35, 36  
-- deep litter, 83-85, 92, 93  
-- floor space requirements, 89  
-- free-range, 11, 12, 81  
-- limited range, 13, 81, 82, 83  
-- principles, 86-89  
-- raised floor/slatted floors, 84, 93, 94  
-- ventilation, 89

weather, 75, 76, 87, 89

ers, 58-61

idity, 52, 84, 86

acted crop, 57

ome  
-- eggs, 154, 162-167  
-- meat, 154, 157

ubation  
-- artificial, 22, 49-55  
-- broody hen/natural, 22, 47, 48  
-- egg selection for, 47-50  
-- equipment, 183, 184

ia poultry, 7, 8

ectious bronchitis, 120, 121  
ectious coryza, 116, 124, 125

Information sources and gathering, 18, 19, 26, 33, 166, 207-210  
Ingredients, feed, 198-202  
Ingredient use limits, 139, 205  
Intestine, 25  
Intestinal coccidiosis, 64, 116, 122-124  
Intestinal worms, 5, 65, 125  
Investment, 16, 33  
    -- layers, 154, 162, 163  
    -- meat-type, 154, 157  
    -- return on, 166  
Isolation pen, 76  
  
Keel bone, 71-74  
Kerosene brooder, 59  
Kidneys, 26, 130  
Killing chickens, 128  
  
Larynx, 25, 129  
Laryngotracheitis, 121  
Layers, 2, 22, 37-39  
    -- breed source, 43-46  
    -- costs, returns and profits, 154, 162, 167  
    -- culling nonlayers, 72-74  
    -- equipment (see Equipment)  
    -- feed consumption, 66, 106  
    -- floor space, 89  
    -- forced molting, 71, 72  
    -- housing (see Housing)  
    -- lighting, 67-71  
    -- management principles, 65-71  
    -- production, eggs, 39, 67, 166, 167  
    -- records, 164, 165  
    -- replacement flocks, 42, 44-46, 63-66  
    -- second year, 71, 72  
    -- start of lay ages, 66, 67  
    -- stress, 2, 75-79  
    -- upgrading through breeding, 37-39, 48, 49  
    -- vs meat/broiler operations, 41, 42, 65, 84, 88, 89  
Lice, 47, 126  
Lighting, 65-71  
    -- step-up vs step-down, 70  
    -- in forced molting, 71, 72  
Lime on litter, 58  
Limited range, 13, 81, 82

Litter (see also Deep litter)

- built-up, 58
- changing, 56
- depth, 57
- eating, 57
- fertilizer value, 3, 83, 84
- hot weather and humidity, 58, 83, 84
- management, 56-58
- types of, 56, 57

Liver, 26, 130

Location of poultry houses, 87

Lungs, 25

Males vs females, 2, 22, 24, 26, 37, 76

Management schedules

- broilers, 63-65
- layer flock replacements, 63-66
- layer flocks, 66-70

Marek's Disease, 121

Manure, 3, 83, 84

Marketing, 32, 34

- eggs, 2, 6, 19, 20, 153, 159-163
- meat, 2, 6, 19, 20, 155-157
- planning, 6, 19, 20, 34, 153
- seasonal considerations, 34, 167
- weight, broilers, 155-160

Mash and grain feeding, 134, 135

Meat vs eggs, 41, 42, 65, 84, 88, 89

Meat breeds, 44, 65

- growth rates, 155, 156
- marketing, 155-157

Medications, 139

- coccidiosis control, 122-125
- worms, 125, 126

Methane, 37, 174

Minerals, 138, 151, 205

Mites, 126, 127

Molt, forced, 71, 72

Mortality rates, 76, 116

Moving, 75

Nests, 36, 111, 112

New Hampshires, 43

Newcastle Disease, 63, 64, 116, 118, 119



Night protection, 35  
Nitrogen-free extract, 136  
Noise, 75  
Non-layers, 72-74  
Nose (nostrils/beak), 25  
Nutrient requirements of poultry, 136-139, 203-206  
    -- energy, 136, 203  
    -- minerals, 138, 205  
    -- protein/amino acids, 131, 137, 204, 205  
    -- vitamins, 138, 203, 204  
    -- other, 139  
Nutrition, 18, 66, 131-152  
    -- country fowl, 36, 37  
    -- commercial feed, 133, 134  
    -- feeding methods, 134, 135  
    -- home-mixed feed, 135  
    -- mixing and formulation, 140-148  
  
Oats (for cannibalism), 77  
Other poultry, 185-191  
Ovary, 26  
Oviduct, 26  
Oyster shells, 110 (see Calcium)  
  
Parasites  
    -- external, 65, 84, 126  
    -- internal, 65, 84, 125, 126  
Peanut shells (see Deep litter)  
Peat moss (see Deep litter)  
Pecking (see Cannibalism)  
Phosphorus, 138  
Pigeon pox (see Fowl pox)  
Pigeons, 190, 191  
Piperazine, 65, 66  
Pipping, 22  
Pits, disposal, 76, 128-130  
Post mortem examination, 119, 128-130  
Poultry keeping  
    -- advantages, 3  
    -- disadvantages, 3, 4  
    -- methods and systems, 81-86  
    -- prerequisites, 4-6  
    -- products, demand for (see Marketing)  
Pox (see Fowl pox)

Predators, 10, 35, 75  
Production  
    -- eggs, 16, 17, 21, 33, 38  
    -- meat, 16, 17, 33, 38, 155, 156  
Profits (see Finance)  
Protein/amino acids, 131, 137, 204, 205  
Proventriculus, 25  
Pubic bones, 71-74  
Pullets, 22, 46  
Pullorum, 122  
  
Quarternary ammonia, 50  
  
Raised floor, 84, 93, 94  
Range  
    -- free, 11, 12, 81  
    -- limited, 13, 81-83  
Rats, 35, 75, 79  
Rearing (brooding), 56, 65  
Records, 153-157, 164-166  
Reproductive system, 25  
Returns on investment (see Finances and Marketing)  
Rhode Island Red, 43  
Rice hulls (see Deep litter)  
Roaster, 2  
Roosters, 37-39  
Roosts, 66, 113  
Routine, 75  
  
Salmonella pullorum, 45, 122  
Salt, 151 (see also Cannibalism)  
Sanitation (see Diseases)  
    -- cleaning between flocks, 52, 56  
    -- disinfectant dip, 92  
Sexed or unsexed chicks, 45  
Sexual maturity  
    -- female pullets, 21, 22  
    -- males, 22  
Shank, 22  
Shavings, 56  
Shells,  
    -- hoppers, 110  
    -- starting chicks, 66  
    -- thin eggs, 138

Water, 139  
-- hot climates, 101  
-- cleanliness, 37  
-- consumption, 100  
-- in incubation, 51, 52, 53  
-- requirements of layers, 47  
-- requirements of starting chicks, 36, 56, 62  
-- space requirements/length/volume, 100

Waterers, 100-104  
Weather, 3, 4, 75, 76  
Weight, 2, 155-157  
White Leghorns, 43  
Whole grain, 134  
Windows, 91  
Wing, 22  
Wire cages, 94-100  
Worms, treatment and control, 5, 65, 66, 125

Yolk, sac, 22

43

Since 1961 when the Peace Corps was created, more than 80,000 U.S. citizens have served as Volunteers in developing countries, living and working among the people of the Third World as colleagues and co-workers. Today 6000 PCVs are involved in programs designed to help strengthen local capacity to address such fundamental concerns as food production, water supply, energy development, nutrition and health education and reforestation.

Peace Corps overseas offices:

<u>BELIZE</u> P.O. Box 487 Belize City	<u>FIJI</u> P.O. Box 1094 Suva	<u>MALAYSIA</u> 177 Jalan Raja Muda Kuala Lumpur	<u>SEYCHELLES</u> Box 564 Victoria
<u>BENIN</u> BP 971 Cotonou	<u>GABON</u> BP 2098 Libreville	<u>MALI</u> BP 85 Bamako	<u>SIERRA LEONE</u> Private Mail Bag Freetown
<u>BOTSWANA</u> P.O. Box 93 Gaborone	<u>GAMBIA, The</u> P.O. Box 582 Banjul	<u>MAURITANIA</u> BP 222 Nouakchott	<u>SOLOMON ISLANDS</u> P.O. Box 547 Honiara
<u>CAMEROON</u> BP 817 Yaounde	<u>GHANA</u> P.O. Box 5796 Accra (North)	<u>MICRONESIA</u> P.O. Box 336 Saipan, Mariana Islands	<u>SWAZILAND</u> P.O. Box 362 Mbabane
<u>CENTRAL AFRICAN REPUBLIC</u> BP 1080 Bangui	<u>GUATEMALA</u> 6a Avenida 1-46 Zona 2 Guatemala	<u>MOROCCO</u> 1, Rue Benzerte Rabat	<u>TANZANIA</u> Box 9123 Dar es Salaam
<u>CHILE</u> Casilla 27-D Santiago	<u>HONDURAS</u> Apartado Postal C-51 Tegucigalpa	<u>NEPAL</u> P.O. Box 613 Kathmandu	<u>THAILAND</u> 42 Soi Somprasong 2 Petchburi Road Bangkok 4
<u>COLOMBIA</u> Carrera 9 #86-26 Bogota	<u>IVORY COAST</u> BP 1127 Abidjan	<u>NIGER</u> BP 10537 Niamey	<u>TOGO</u> BP 3194 Lome
<u>COSTA RICA</u> Apartado Postal 1266 San Jose	<u>JAMAICA</u> 9 Musgrove Avenue Kingston 10	<u>OMAN</u> P.O. Box 966 Muscat	<u>TONGA</u> BP 147 Nuku'Alofa
<u>DOMINICAN REPUBLIC</u> Apartado Postal 1414 Santo Domingo	<u>KENYA</u> P.O. Box 30518 Nairobi	<u>PAPUA NEW GUINEA</u> c/o American Embassy Port Moresby	<u>TUNISIA</u> 8, Ave. Louis Braille Tunis
<u>EASTERN CARRIBBEAN</u> Including: Antigua Barbados, Grenada, Montserrat, St. Kitts-Nevis, St. Lucia, St. Vincent, Dominica "Erin Court" Bishops Court Hill P.O. Box 696-C Bridgetown, Barbados	<u>KOREA</u> Gwang Wha Moon P.O. Box 521 Seoul	<u>PARAGUAY</u> c/o American Embassy Asuncion	<u>UPPER VOLTA</u> BP 537-Samandin Ouagadougou
<u>ECUADOR</u> Casilla 635-A Quito	<u>LESOTHO</u> P.O. Box 554 Maseru	<u>PHILIPPINES</u> P.O. Box 7013 Manila	<u>WESTERN SAMOA</u> P.O. Box 880 Apia
<u>MALAWI</u> Box 208 Lilongwe	<u>LIBERIA</u> Box 707 Monrovia	<u>RWANDA</u> c/o American Embassy Kigali	<u>YEMEN</u> P.O. Box 1151 Sana'a
<u>SENEGAL</u> BP 254 Dakar	<u>ZAIRE</u> BP 697 Kinshasa		